



# FILTRI IDRAULICI

Hydraulic filter - Hydraulikfilter  
Filtres hydrauliques - Filtros de hidráulica

# INDICE - INDEX



## **Introduzione** .....Pag. **2**

Introduction  
Einführung  
Introduction  
Introducción



## **Cartucce intercambiabili** .....Pag. **5**

Interchangeable elements  
Austausch-Filterelemente  
Eléments interchangeables  
Elementos intercambiables



## **Filtri immersi (ASPIRAZIONE) - Serie FI-FR-XFS** .....Pag. **10**

Immersed filters (SUCTION) > FI-FR-XFS Series  
Eingetauchtsaugfilter (SAUG-) > Serie FI-FR-XFS  
Filtres immergés (ASPIRATION) > Serie FI-FR-XFS  
Filtros sumergidos (ASPIRACION) > Serie FI-FR-XFS



## **Filtri in linea bassa pressione (ASPIRAZIONE, MANDATA, RITORNO) - Serie FB-HL** .....Pag. **22**

In-line low pressure filters (SUCTION, DELIVERY or RETURN) > FB-HL Series  
Leitungsfiler für Niederdruck (SAUG-, DRÜCK- und RÜCKLAUF) > Serie FB-HL  
Filtres en ligne basse pression (ASPIRATION, REFOULEMENT ou RETOUR) > Serie FB-HL  
Filtros en linea (ASPIRACION, PRESION o RETORNO) > Serie FB-HL



## **Filtri per montaggio al serbatoio (ASPIRAZIONE, RITORNO) - Serie SIF-FSI-HR-FAR** .....Pag. **32**

Tank-top filters (SUCTION, RETURN) > SIF-FSI-HR-FAR Series  
Tankeinbaufilter (SAUG-, RÜCKLAUF) > Serie SIF-FSI-HR-FAR  
Filtres pour montage au reservoir (ASPIRACION, RETOUR) > Serie SIF-FSI-HR-FAR  
Filtros para montaje al deposito (ASPIRACION, RETORNO) > Serie SIF-FSI-HR-FAR



## **Filtri in linea alta pressione (MANDATA) Serie PF1-PF2-PF3-PF4** .....Pag. **50**

In-line high pressure filters (DELIVERY) > PF1-PF2-PF3-PF4 Series  
Hochdruckfilter (DRÜCK-) > Serie PF1-PF2-PF3-PF4  
Filtres en ligne haute pression (REFOULEMENT) > Serie PF1-PF2-PF3-PF4  
Filtros en linea de alta presión (PRESION) > Serie PF1-PF2-PF3-PF4



## **Accessori serbatoio Serie LO-SL-TP-FAS-PV** .....Pag. **68**

Tank fittings > LO-SL-TP-FAS-PV Series  
Tankzubehören > Serie LO-SL-TP-FAS-PV  
Accessories pour réservoir > Serie LO-SL-TP-FAS-PV  
Accesorios para depósito > Serie LO-SL-TP-FAS-PV

Copyright© 2012 F.B.N. Srl - Settima edizione: giugno 2012 - Seventh edition: june 2012

INFORMAZIONI GENERALI: Le indicazioni contenute su questo catalogo sono state elaborate con la maggior cura possibile, tuttavia non sono vincolanti. Non si accetta quindi alcuna responsabilità per inesattezze od omissioni che possano eventualmente verificarsi. In caso di dubbio, Vi preghiamo contattare il nostro ufficio commerciale. La FBN srl si ritiene libera di modificare o aggiornare questo catalogo senza alcun preavviso e si riserva tutti i diritti della presente pubblicazione. Ogni riproduzione, anche parziale, è quindi vietata senza nostro accordo.

GENERAL INFORMATION: The indications contained in this catalogue have been worked out very carefully, however they are not binding. No responsibility can be accepted for any mistakes or omissions which may have occurred. In case of doubt, please contact our sales department. FBN srl considers itself free at any time to modify or update this catalogue and reserves all the rights to this publication. Any reproduction, even partial, is forbidden without our previous agreement.

COMPANY WITH QUALITY MANAGEMENT  
SYSTEM CERTIFIED BY DNV  
= ISO 9001:2008 =







F.B.N. Srl nasce come costruttore di filtri nel settore agricolo-industriale nei primi anni '60 a Novellara (RE), in una zona altamente qualificata e riconosciuta a livello mondiale nel settore metalmeccanico con forte specializzazione nel campo dell'oleodinamica.

La nostra lunga storia, esperienza e collaborazione con i principali clienti ci ha consentito di sviluppare, negli anni, una gamma completa di filtri per applicazioni oleodinamiche in grado di soddisfare tutte le esigenze, dal mercato del ricambio a quello del primo equipaggiamento OEM.

**QUALITÀ, FLESSIBILITÀ e SERVIZIO** sono per F.B.N. l'obiettivo principale, perseguito all'interno di un progetto globale che dalla progettazione alla consegna, attraverso tutte le fasi del ciclo produttivo, mira ad un unico scopo: **la totale soddisfazione del cliente.**

L'azienda, certificata ISO9001:2008, è in grado inoltre di sviluppare qualsiasi progetto su specifica richiesta del cliente: l'ampiezza e la continua espansione della nostra gamma ne è la riprova.

F.B.N. Srl was founded as manufacturer of filters for agricultural and industrial applications in the early 60s in Novellara (RE), an highly qualified area and globally recognized in the mechanics sector with a strong specialization in the field of hydraulics.

Our long history, experience and cooperation with key customers has allowed us to develop, over the years, a complete range of filters for hydraulic applications to meet all needs, from the aftermarket to the OEM field.

**QUALITY, FLEXIBILITY and SERVICE** are for FBN the main targets, pursued in a global project from design to delivery through all stages of production, aimed at one goal: **the total customer satisfaction.** The company, certified ISO9001:2008, is also able to develop any new project on customer's request: our wide range and the continue expansion of our products is a proof of it.







**D** F.B.N. Srl wurde in den frühen 60er Jahren als Hersteller von Filtern für landwirtschaftliche und industrielle Bereiche in Novellara (RE) gegründet - eine hoch qualifizierte, auf dem Mechanik-Sektor weltweit bekannte Region mit starker Ausrichtung auf den Bereich der Hydraulik. Unsere langjährige Firmengeschichte, die damit verbundene Erfahrung und die enge Zusammenarbeit mit unseren Kunden haben dazu beigetragen, dass wir im Laufe der Zeit ein komplettes Filterprogramm für hydraulische Anwendungen entwickeln konnten. Sowohl auf dem Zubehörmarkt, als auch im Erstausrüster-Bereich erfüllen unsere Filter alle Anforderungen.

**QUALITÄT, FLEXIBILITÄT** und **SERVICE** sind für F.B.N. die wichtigsten Grundsätze. Von der Planung bis zur Auslieferung, also durch sämtliche Produktionsstufen, verfolgen wir ein Ziel: **die absolute Kundenzufriedenheit**. Unser Unternehmen (zertifiziert nach ISO9001:2008) ist in der Lage, jedes neue Projekt Speziell nach Kundenwunsch zu realisieren. Unsere breite Auswahl und die kontinuierliche Erweiterung unseres Produktprogramms sind Beweis dafür.

**FR** F.B.N. Srl a été fondée comme fabricant de filtres pour applications agricoles et industrielles au début des années 60' chez Novellara (RE), dans une zone hautement qualifiés et reconnus mondialement dans le secteur de la mécanique avec une forte spécialisation dans le domaine de l'hydraulique.

Notre longue histoire, l'expérience et la coopération avec les principaux clients nous a permis de développer, au cours des années, une gamme complète de filtres pour applications hydrauliques pour satisfaire tous les besoins, de l'après-vente au premier montage OEM.

**QUALITÉ, FLEXIBILITÉ** et **SERVICE** sont les principales cibles de FBN, poursuivi dans un projet global a partir du projet à la livraison à travers toutes les étapes de production, visant à un seul objectif: **la satisfaction totale du client**. L'entreprise, certifiée ISO9001: 2008, est également en mesure de développer tout nouveau projet sur demande du client: notre gamme et l'expansion continue de nos produits c'est la démonstration.

**ES** F.B.N. Srl nace como fabricante de filtros en el sector agrícola-industrial en los años 60 en Novellara (RE), en una zona altamente cualificada y reconocida a nivel mundial en el sector metalomecánico con fuerte especialización en el campo de la oleodinámica.

Nuestra larga historia, experiencia y colaboración con los principales clientes nos ha permitido desarrollar en estos años una completa gama de filtros para aplicaciones oleodinámicas en grado de satisfacer todas las exigencias del mercado desde el recambio al primer equipo OEM.

**CALIDAD, FLEXIBILIDAD** y **SERVICIO** son para F.B.N. el objetivo principal, siguiendo un proyecto global que desde el diseño hasta la entrega, a través de todas las fases del ciclo productivo, mira un único fin: **la total satisfacción del cliente**.

La compañía, certificada ISO9001:2008, está en grado de desarrollar cualquier proyecto basado en la demanda del cliente: la amplia y continua expansión de nuestra gama es la prueba.

# Cartucce Intercambiabili

Interchangeable Elements - Austausch Filterelemente  
Eléments Interchangeables - Elementos Intercambiables

**IT** F.B.N. Srl è lieta proporvi la propria gamma di elementi filtranti intercambiabili con tutti i maggiori costruttori mondiali di macchinari (OEM) e filtri idraulici. I nostri elementi intercambiabili sono prodotti con componenti di elevatissima qualità e controllati costantemente in modo da garantire le massime prestazioni, equivalenti agli originali. Si tratta di una gamma in continua espansione, vi invitiamo a consultare la nostra tabella elettronica di comparazione on-line per visualizzare le equivalenze: **www.fbn.it/reference**. In caso in cui le equivalenze non fossero trovate, possiamo valutarne la costruzione anche per quantità modeste. Contattateci!!

**EN** F.B.N. srl is pleased to offer you its range of filter elements, interchangeable with all main manufacturers of equipments (OEM) and hydraulic filters. Our interchangeable elements are produced with components of the highest quality level and are constantly monitored to ensure maximum performance, equivalent to the original. It is an ever-expanding range, We kindly invite you to see our online cross-reference to check the equivalences: **www.fbn.it/reference**. In case the equivalences are not found, we can evaluate the building also for modest quantities. Contact us!







**D** Die Firma F.B.N. srl freut sich, Ihnen ihr breit gefächertes Programm an Filterelementen vorstellen zu dürfen. Unser Sortiment ist kompatibel zu allen wichtigen Herstellern von Maschinen (OEM) und Hydraulikfiltern. Unsere austauschbaren Filterelemente werden ausschließlich mit Komponenten von höchster Qualität hergestellt und dabei stetig überwacht. Das garantiert maximale Leistung, die dem Original in nichts nachsteht. Unser Angebot wächst ständig. Wir laden Sie herzlich ein, sich zu Vergleichszwecken auch unsere Online-Referenzliste anzusehen: **www.fbn.it/reference**. Sollten Sie einen gewünschten Artikel wider Erwarten nicht finden - wir produzieren (auch Kleinstmengen) speziell für Sie. Kontaktieren Sie uns einfach!

**FR** F.B.N. srl est heureux de vous offrir sa gamme d'éléments filtrants interchangeable avec tous les principaux fabricants d'équipements (OEM) et des Filtres hydrauliques. Nos éléments interchangeables sont produits avec des composants de plus haut niveau de qualité et sont surveillés constamment, pour assurer les performances maximales, équivalentes à l'original. Il s'agit d'une gamme toujours en expansion, nous vous invitons à voir notre table des correspondances en-ligne pour vérifier les équivalences: **www.fbn.it/reference**. Dans le cas où les équivalences ne sont pas trouvées, nous pouvons évaluer la construction même pour des quantités modestes. Contactez-nous!

**ES** F.B.N. se complace de proponerle la propia gama de elementos filtrantes intercambiables con los mayores constructores mundiales de maquinaria (OEM) y filtros hidráulicos. Nuestros elementos intercambiables están producidos con componentes de elevada calidad y controlados constantemente en modo de garantizar las máximas prestaciones equivalentes a los originales. Se trata de una gama en continua expansión, por lo que les invitamos a consultar nuestra página de cruces de referencias on-line: **www.fbn.it/reference**. En caso de que la equivalencia no fuese encontrada, podemos cotizar la construcción también para pequeñas cantidades. ¡Contactenos!.

**www.fbn.it/reference**







**f b n**

NOVELLAM

CAMBIO



#### **IT L'IMPORTANZA DEL FILTRO IN UN SISTEMA OLEODINAMICO:**

Nei sistemi oleodinamici moderni, i costruttori tendono ad utilizzare componenti per la produzione ed il controllo della potenza idraulica sempre più complessi, costosi e dalle elevate prestazioni. **LA CAUSA PRINCIPALE DEI GUASTI IN QUESTI SISTEMI È CONSEGUENZA DIRETTA DELLA CONTAMINAZIONE DEL FLUIDO IDRAULICO ED I COSTI CHE NE DERIVANO SONO ELEVATI** (sostituzione dei componenti, fermi produttivi, aumento dei costi di manutenzione, etc. etc.). È impossibile eliminare completamente la contaminazione dai fluidi ma si può tenere sotto controllo mediante la corretta scelta di un filtro ed il ricambio costante dell'elemento filtrante. Ecco perché scegliere un filtro idoneo al proprio sistema ed applicazione oleodinamica, significa **RIDURRE I COSTI DI ESERCIZIO E MANTENERE ELEVATE LE SUE POTENZIALITÀ**. Per scegliere un filtro corretto, occorre analizzare diversi fattori:

**1)** Posizione nel circuito (aspirazione, mandata, ritorno); **2)** la pressione massima di esercizio considerando anche il  $\Delta p$  dell'elemento filtrante; **3)** Portata massima necessaria, dimensionamento ed attacchi; **4)** Grado di filtrazione e tipologia dell'elemento filtrante necessario per proteggere i componenti. Per determinarlo, occorre tenere conto di numerosi parametri come: a) Il livello richiesto di pulizia del fluido richiesta, secondo norma ISO4406 o NAS1638 e quindi l'efficienza filtrante più idonea, b) La sensibilità dei componenti da proteggere, c) L'aspettativa di durata (cicli) e la capacità di accumulo di contaminante, d) L'ambiente di lavoro, e) I costi generali, anche per eventuali fermi produttivi; **5)** Le temperature di esercizio; **6)** Utilizzo eventuale di Indicatori di intasamento o by-pass. F.B.N. Srl è in grado di proporvi una gamma per soddisfare tutte le vostre esigenze. Il nostro ufficio tecnico è a vostra completa disposizione per qualsiasi richiesta di informazioni supplementari e chiarimenti tecnici.

#### **EN THE IMPORTANCE OF A FILTER IN AN HYDRAULIC SYSTEM:**

In modern hydraulic systems, manufacturers tend to use components for production and control of hydraulic power, increasingly complex, expensive and with very high performances. **THE MAIN CAUSE OF BREAKDOWNS IN THESE SYSTEMS IS A DIRECT CONSEQUENCE OF HYDRAULIC FLUID'S CONTAMINATION AND THE DERIVING COSTS ARE REALLY HIGH** (components' replacements, production stops, increased maintenance costs, etc.etc.). It is impossible to eliminate completely contamination from fluids but it can be kept under control by proper choice of a filter and the constant replacement of its filter element. That's why, choosing a suitable filter for your hydraulic system and application, means **A REDUCTION OF THE OPERATING COSTS AND KEEPING HIGH ITS POTENTIAL**. You must analyze several factors, to select a proper filter:

**1)** Location on the circuit (suction, delivery, return); **2)** The Max. working pressure considering also the filter element  $\Delta p$ ; **3)** Max. flow rate needed, filter dimensions and connections; **4)** Filtration degree and filtering material necessary to protect components. You must take into account several parameters in order to determine it, such as: a) The required level of contamination class according to standards ISO4406 or NAS1638 and therefore the most suitable filtering efficiency, b) The sensitivity of components to be protected, c) The expected life (cycles) and the dirt holding capacity, d) The working environment, e) The general costs, also for evtl. production stops; **5)** The working temperatures; **6)** The eventual usage of clogging indicators or by-pass. F.B.N. Srl is able to offer you a range to suit all your needs. Our technical department is at your complete disposal for any request for additional information and technical explanations.

#### **D DIE BEDEUTUNG VON FILTERN IN HYDRAULISCHEN SYSTEMEN:**

In modernen hydraulischen Systemen werden sowohl in der Produktion als auch im täglichen Betrieb zunehmend komplexere und teurere Hochleistungskomponenten verwendet. **DIE HAUPTURSACHEN FÜR SCHÄDEN AN DIESEN SYSTEMEN SIND DIE FOLGEN VON VERUNREINIGUNGEN IN HYDRAULIKFLÜSSIGKEITEN - DIE DADURCH ENTSTEHENDEN KOSTEN SIND BEKANNTLICH SEHR HOCH** (Ersatzteile, Produktionsausfall, Wartungskosten, etc.). Es ist natürlich unmöglich, wirklich alle Verunreinigungen durch reine Filtration aus dem Öl zu entfernen. Die Wahl des richtigen Filters und der regelmäßige Austausch der Filterelemente garantiert jedoch ein bestmögliches Ergebnis. Deshalb bedeutet ein hochwertiger Filter eine **MINIMIERUNG IHRER BETRIEBSKOSTEN UND SORGT FÜR EINE KONSTANTE LEISTUNGSFÄHIGKEIT** Ihrer hydraulischen Systeme und -Anlagen. Sie sollten folgende Faktoren beachten, um den korrekten Filter auszuwählen:

**1)** Die Positionierung im Ölkreislauf (Saugleitung, Rücklaufleitung, etc.); **2)** Den maximalen Arbeitsdruck unter Berücksichtigung des Filterelements  $\Delta p$ ; **3)** Die benötigte maximale Durchflussmenge, die Filterdimensionen und die Anzahl der Verbindungen; **4)** Die Filterfeinheit und das Filtermaterial, das notwendig ist, um die Bauteile bestmöglich zu schützen. Hier müssen mehrere Parameter beachtet werden, bspw.: a) Die Reinheitsvorschriften gemäß ISO 4406 oder NAS1638 (und damit die ideale Filterleistung), b) Die Empfindlichkeit der zu schützenden Komponenten, c) Die erwartete Lebensdauer und die Schmutzaufnahmekapazität, d) Das Arbeitsumfeld, e) Die allgemeinen Kosten, auch für einen eventuellen Produktionstop **5)** Die Arbeitstemperaturen; **6)** Die potentielle Verwendung von Verschmutzungsanzeigen oder Bypass-Ventilen. F.B.N. Srl ist im Stande, Ihnen ein Angebot zu machen, das all Ihre Bedürfnisse abdeckt. Unsere technische Abteilung steht Ihnen jederzeit gerne für zusätzliche Informationen und technische Erläuterungen zur Verfügung.

#### **FR L'IMPORTANCE D'UN FILTRE DANS UN SYSTEME HYDRAULIQUE:**

Dans les systèmes hydrauliques modernes, les fabricants ont tendance à utiliser des composants pour la production et le contrôle de la puissance hydraulique, de plus en plus complexe, coûteux et avec très hautes performances. **LA CAUSE PRINCIPALE DES PANNES DANS CES SYSTÈMES, EST UNE CONSÉQUENCE DIRECTE DE LA CONTAMINATION DU FLUIDE HYDRAULIQUE ET LES COÛTS DÉCOULANT SONT TRÈS ÉLEVÉS** (remplacements des composants, arrêts de production, l'augmentation des coûts de maintenance, etc.etc. ). Il est impossible d'éliminer complètement la contamination de fluides, mais il peut être maintenu sous contrôle par un choix approprié d'un filtre et le remplacement constant de son élément filtrant. C'est pourquoi, le choix d'un filtre approprié pour votre système hydraulique et application, signifie **REDUIRE LES COÛTS DE GESTION ET MAINTENIR ÉLEVÉ SON POTENTIEL**. Vous devez analyser plusieurs facteurs, pour sélectionner un filtre approprié:

**1)** Position sur le circuit (aspiration, refoulement, retour); **2)** La pression max. de travail en tenant compte également du  $\Delta p$  de l'élément filtrant; **3)** Le débit Max. nécessaire, les dimensions du filtre et les connexions; **4)** Degré de filtration et le matériel filtrant nécessaire pour protéger les composants. Vous devez prendre en considération plusieurs paramètres pour le définir, comme : a) Le niveau requis de classe de contamination selon les normes ISO4406 ou NAS1638 et donc l'efficacité de filtrage le plus approprié, b) La sensibilité des composants à protéger, c) La durée de vie prévue (cycles) et la capacité de rétention, d) L'environnement de travail, e) Les frais généraux, également pour evtl. arrêts de production; **5)** Les températures de travail; **6)** L'utilisation éventuelle des indicateurs de colmatage ou de by-pass. F.B.N. Srl peut vous offrir une gamme pour répondre à tous vos besoins. Notre service technique est à votre entière disposition pour toutes les demandes d'informations complémentaires et les explications techniques.

#### **ES LA IMPORTANCIA DEL FILTRO EN UN SISTEMA OLEODINÁMICO:**

En los sistemas oleodinámicos modernos, los constructores tienden a utilizar componentes para la producción y el control de la potencia hidráulica siempre más complejos, costosos y de elevadas prestaciones. **LA CAUSA PRINCIPAL DE LAS AVERIAS EN ESTOS SISTEMAS ES CONSECUENCIA DIRECTA DE LA CONTAMINACIÓN DEL FLUIDO HIDRÁULICO Y LOS COSTES DERIVADOS SON ELEVADOS** (sustitución de los componentes, paradas productivas, aumento de los costos de mantenimiento, etc.). Es imposible eliminar completamente la contaminación de los fluidos pero se puede tener bajo control mediante la correcta elección de un filtro y el recambio regular del elemento filtrante. Es por esto que elegir un filtro idóneo al propio sistema y aplicación oleodinámica significa **REDUCIR COSTOS Y MANTENER ELEVADA SU POTENCIALIDAD**. Para elegir un filtro correcto se necesita analizar diversos factores:

**1)** Posición en el circuito (aspiración, presión, retorno); **2)** la presión máxima de ejercicio considerando también el  $\Delta p$  del elemento filtrante; **3)** Caudal máximo necesario, dimensiones y conexiones; **4)** Grado de filtración y tipología del elemento filtrante necesario para proteger los componentes. Para determinarlo, se deben tener en cuenta diversos parámetros como: a) El nivel necesario de limpieza del fluido, según norma ISO4406 ó NAS1638 y por tanto la eficiencia filtrante mas idonea. b) La sensibilidad de los componentes a proteger. c) La expectativa de duración (ciclos) y la capacidad de acumulación de contaminantes. d) El ambiente de trabajo. e) Los costos generales, también para eventuales paradas productivas; **5)** La temperatura de ejercicio; **6)** Utilización de indicadores de colmatación y by-pass.F.B.N. Srl se encuentra en grado de proponer una gama para satisfacer todas sus exigencias. Nuestra oficina técnica está a su completa disposición para cualquier demanda de información suplementaria y explicación técnica.

# Catalogo filtri idraulici

## Hydraulic filter catalogue

## Hydraulikfilter-Katalog

## Catalogue filtres hydrauliques

## Catalogo filtros de hidráulica

### ESEMPI DI APPLICAZIONE EXAMPLES OF APPLICATION

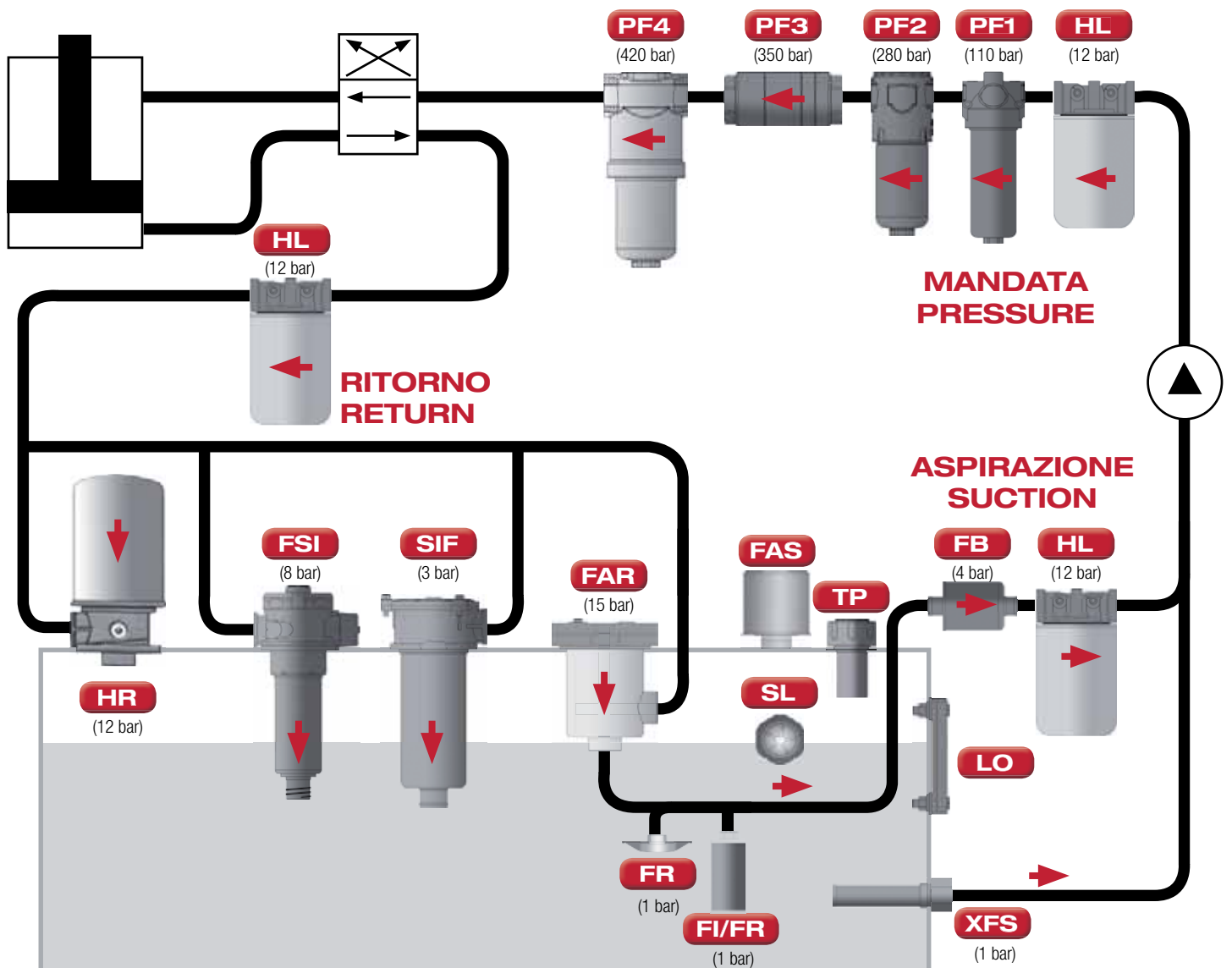

 = Pompa oleodinamica - Hydraulic pump

 = Valvola - Valve

 = Cilindro oleodinamico - Hydraulic cylinder



# Filtri Aspirazione Immersi

## SERIE FI-FR-XES

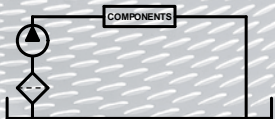
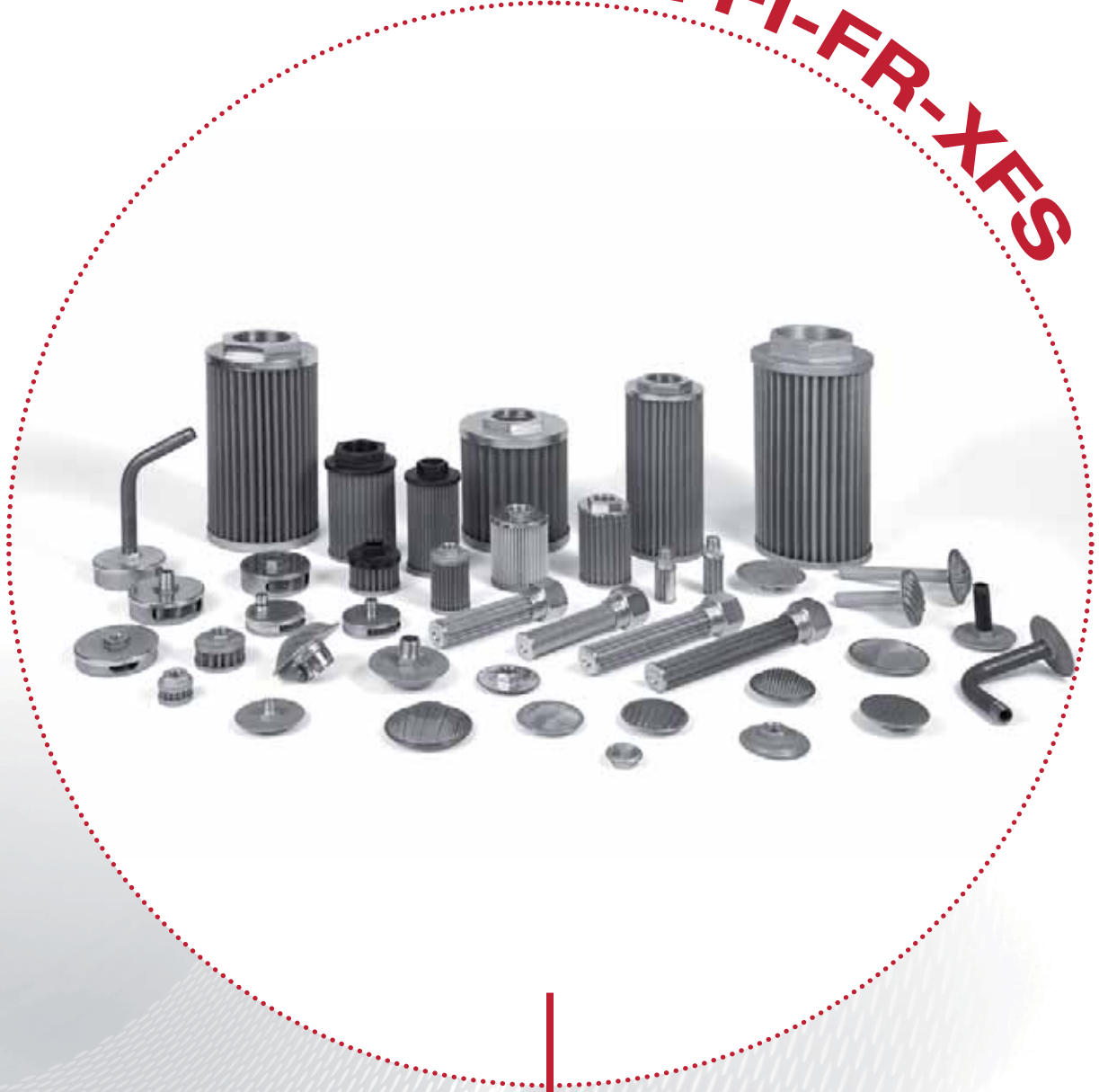

Filtri in aspirazione  
Suction filters  
Saug filter  
Filtres d'aspiration  
Filtros en aspiracion

GB

**Immersed suction filters (strainers)**

D

**Saugfilterelemente**

FR

**Filtres aspiration immergés (crepines)**

ES

**Filtros de aspiración sumergidos**

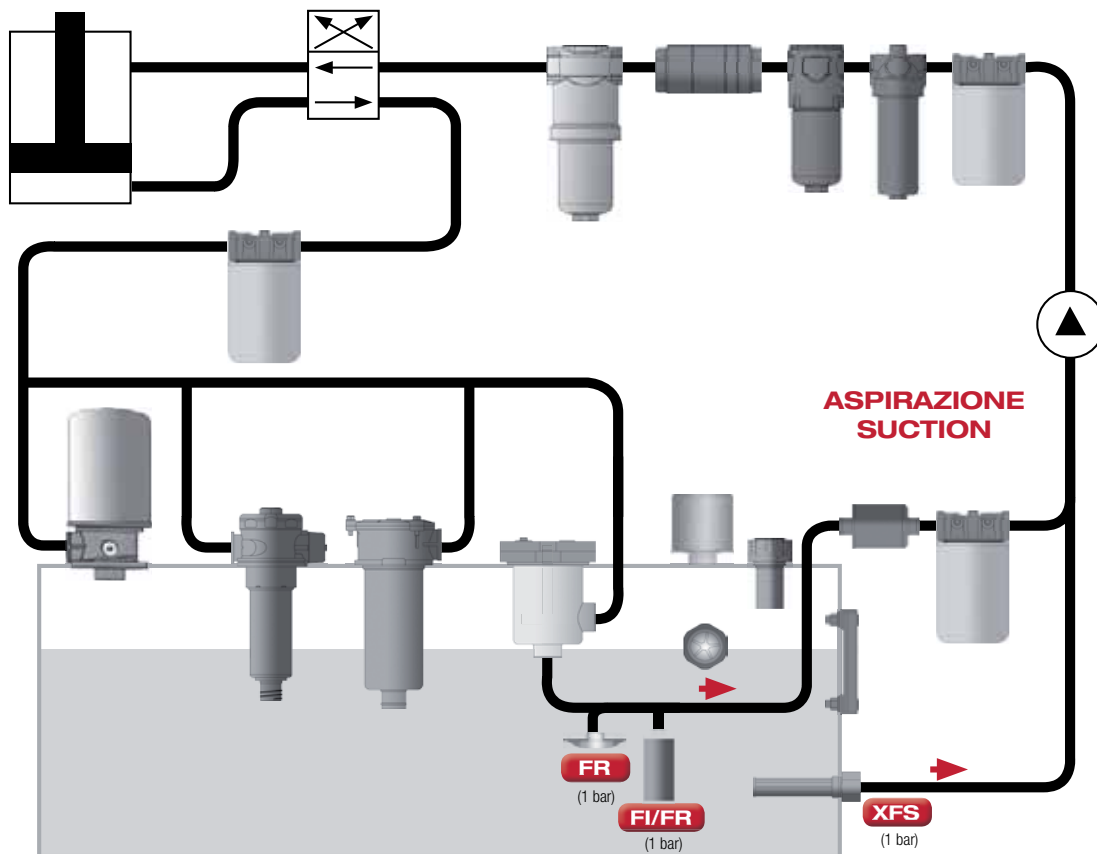

**IT** I filtri serie FI-FR-XFS vengono utilizzati in aspirazione, immersi nel serbatoio olio idraulico, per proteggere la pompa ed i componenti del sistema da una contaminazione grossolana. Sono disponibili diverse serie di famiglie e modelli per soddisfare tutte le esigenze: vari gradi di filtrazione ed attacchi, piccole portate per mini centraline, portate maggiori, spazi ristretti, attacchi speciali o con tubi pescaggio. Possiamo inoltre realizzare filtri speciali su richiesta del cliente.

**GB** FI-FR-XFS filter series are used for suction, immersed into hydraulic oil tank, to protect the pump and system components from coarse contamination. There are several filter families and models available, in order to satisfy all needs: many filtration degrees and connections, small flow rates for mini power-packs, bigger flow rates, narrow spaces, special connections or with suction pipes. We can also produce special filters upon customer request.

**D** Die Saugfilterelemente-Serie FI-FR-XFS wird in den Öltank integriert, um eine bestmögliche Grobfiltration für Pumpen und Systemkomponenten zu gewährleisten. Es stehen Ihnen verschiedene Filterfamilien und-Modelle zur Verfügung, bspw: Filter mit verschiedenen Feinheitsgraden und-Anschlussarten, mit kleinen Durchflussmengen (Miniaggregate), für größere Volumenströme, für beengte Verhältnisse, mit Sondenschlüssen oder auch mit Saugleitungen. Und: Wir stellen wir auch Filter speziell nach Kundenwunsch.

**FR** Les filtres serie FI-FR-XFS sont utilisés en aspiration, immergés dans le réservoir hydraulique, pour protéger la pompe et les composants du système contre une contamination grossière. Il'ya différentes familles et modèles disponibles: nombreux degrés de filtration et connexions, petits débits pour mini centrales, grands débits, espaces étroits, connexions spéciales ou avec tubes aspiration. Nous pouvons aussi produire filtres spéciaux sur demande du client.

**ES** Los filtros FI-FR-XFS vienen utilizados en aspiración, sumergidos en el depósito para proteger la bomba de una contaminación gruesa. Están disponibles distintas series de familias y modelos para satisfacer todas las exigencias: varios grados de filtración y conexión, pequeños caudales para minicentrales, caudales mayores, espacio reducido, conexiones especiales ó con tubo acoplado. Podemos además realizar filtros especiales bajo diseño del cliente.



# SERIE FI

## IT Filtri aspirazione olio idraulico immersi nel serbatoio con attacco filettato

### CARATTERISTICHE TECNICHE:

- Fondelli + attacchi: acciaio zincato.
- Tubo interno: lamiera forata in acciaio zincato.
- Attacchi disponibili standard: da 3/8" a 3" ("bspp"). "Npt" o altre filettature su richiesta.
- Elementi filtranti disponibili standard: 30 Micron nom. Carta / 60-90-250 Micron nom. Tela metallica. Altre filtrazioni su richiesta.
- By-pass: fornibile su richiesta (apertura 0,3 bar).
- Temperatura esercizio: da -30°C a +110°C.
- Pressione collasso: 1 bar.
- Test eseguiti secondo normative: ISO 2941 / ISO 3724 / ISO 3968.

## EN Threaded tank-immersed suction oil filters

### TECHNICAL FEATURES:

- Connections + caps: galvanized steel.
- Inner pipe: galvanized perforated plate.
- Standard available threads: from 3/8" to 3" ("bspp"). "Npt" or other threads available upon request.
- Standard available filter elements: 30 Micron nom. paper / 60-90-250 Micron nom. wire mesh. Other filtrations upon request.
- By-pass: available upon request (0,3 bar opening).
- Working temperature: from -30°C to +110°C.
- Collapse pressure: 1 bar.
- Tested according standards: ISO 2941 / ISO 3724 / ISO 3968.

## D Eingetauchtsaugfilter mit Gewindeanschluß

### TECHNISCHE DATEN:

- Endkappe + Anschluß: verzinktem Stahl.
- Innen Rohr: verzinktem Lochblech.
- Standard Anschlußgewinde: von 3/8" bis 3" („bspp“). „Npt“ oder weitere Gewinden auf Anfrage erhältlich.
- Standard Filterelemente: 30 Mikron nom. Papier / 60-90-250 Mikron nom. Drahtgewebe. Weitere Materialien auf Anfrage erhältlich.
- By-pass Ventil: auf Anfrage (0,3 bar Eröffnung).
- Betriebstemperatur: von -30°C bis +110°C.
- Kollapsdrücke: 1 bar.
- Test nach Normen: ISO 2941 / ISO 3724 / ISO 3968.

## FR Crepines d'aspiration

### CARACTERISTIQUES TECHNIQUES:

- Flasques + connexions: acier zingué.
- Tube central: toles perforée en acier zingué.
- Raccordements standard: de 3/8" à 3" ("bspp") "Npt" ou autres filetages disponibles sur demande.
- Eléments filtrants: 30 Micron nom. Papier / 60-90-250 Micron nom. Toile metalique. Autres matériaux disponibles sur demande.
- Clapet By-pass: sur demande (ouverture 0,3 bar).
- Temperature de travaille: de -30°C à +110°C.
- Pression d'écrasement: 1 bar.
- Test selon standards: ISO 2941 / ISO 3724 / ISO 3968.

## ES Filtros en aspiración sumergidos

### CARACTERÍSTICAS TÉCNICAS:

- Fondos y conexiones: acero cincado.
- Tubo interno: chapa perforada en acero cincado.
- Conexiones disponibles estandar: de 3/8" a 3" ("bspp") "Npt" o otras conexiones bajo pedido.
- Elemento filtrante disponible estandar: 30 micras nom. papel / 60-90-250 micras nom. tela metálica. Otras filtraciones bajo pedido.
- By-pass: Bajo pedido (apertura 0,3bar).
- Temperatura de ejercicio: de -30°C a +110°C.
- Presión de colapso: 1 bar
- Controles seguidos según normativas: ISO 2941 / ISO 3724 / ISO 3968.

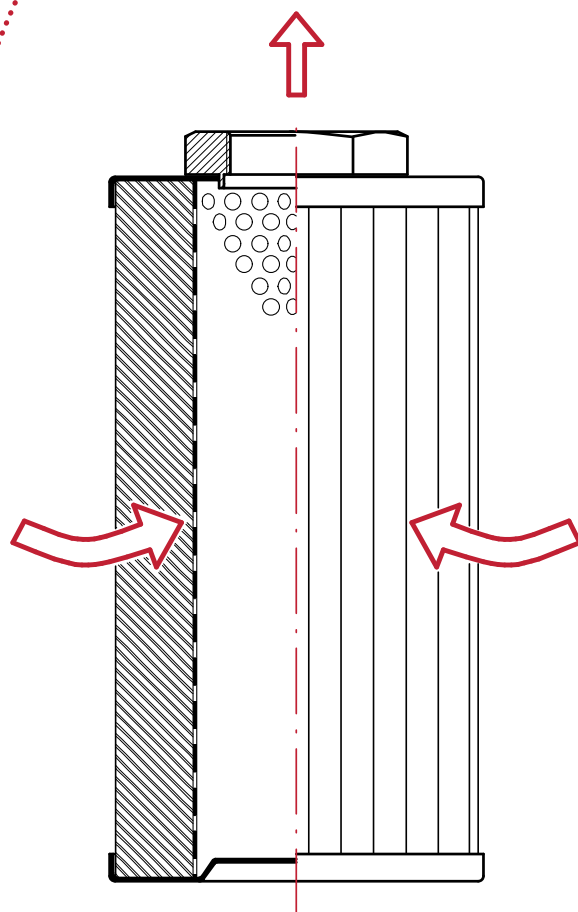

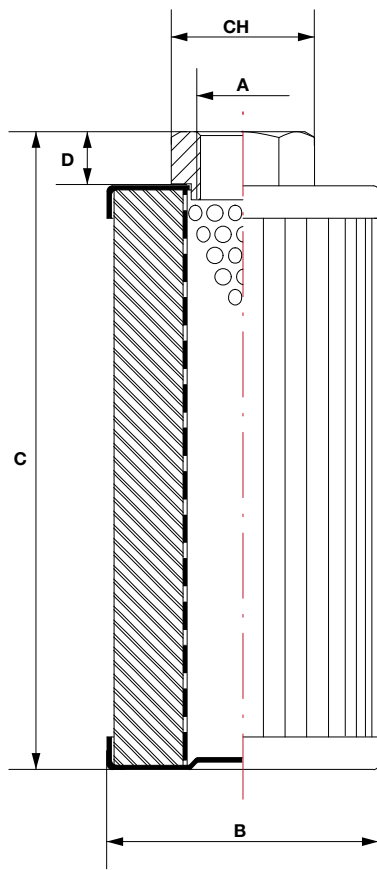

DIMENSIONI (mm) DIMENSIONS (mm)					
Mod.	A*	B	C	D	CH
<b>FI1.10</b>	3/8"	50	89	8	22
<b>FI2.10</b>	1/2"				30
<b>FI2.15</b>		3/4"	69	93	8
<b>FI3.15</b>	1"				
<b>FI3.20</b>		140	93	10	60
<b>FI4.20</b>	1" 1/4				
<b>FI4.25</b>		1" 1/2	100	105	10
<b>FI4.30</b>	2"				
<b>FI5.30</b>		2" 1/2	140	213	10
<b>FI5.35</b>	3"				
<b>FI5.40</b>		268	16	326	16
<b>FI5.45</b>	290				
<b>FI6.40</b>		290	26	326	16
<b>FI6.50</b>	290				
<b>FI6.55</b>		290	26	326	16
<b>FI7.55</b>	290				
<b>FI7.60</b>		290	26	326	16
<b>FI7.65</b>	290				
<b>FI7.70</b>		290	26	326	16
<b>FI8.65</b>	290				
<b>FI8.70</b>		290	26	326	16
<b>FI9.70</b>	290				

PORTATE (l/min) FLOW RATES (l/min)				
Mod.	M30	M60	M90	MD5
<b>FI1.10</b>	6	12	12	12
<b>FI2.10</b>	10	18	18	18
<b>FI2.15</b>	10	18	18	18
<b>FI3.15</b>	15	28	28	28
<b>FI3.20</b>	15	28	28	28
<b>FI4.20</b>	25	45	45	45
<b>FI4.25</b>	25	50	50	50
<b>FI4.30</b>	25	50	50	50
<b>FI5.30</b>	35	70	70	70
<b>FI5.35</b>	35	70	70	70
<b>FI5.40</b>	35	70	70	70
<b>FI5.45</b>	40	80	80	80
<b>FI6.40</b>	50	100	100	100
<b>FI6.50</b>	55	110	110	110
<b>FI6.55</b>	55	110	110	110
<b>FI7.55</b>	80	130	130	130
<b>FI7.60</b>	95	180	180	180
<b>FI7.65</b>	110	220	220	220
<b>FI7.70</b>	120	250	250	250
<b>FI8.65</b>	150	300	300	300
<b>FI8.70</b>	150	300	300	300
<b>FI9.70</b>	200	400	400	400

\* Filettatura standard "bspp". Eventuale filettatura "npt" o speciale su richiesta.

\* Standard threads "bspp". "Npt" or special threads upon request.

\* Portate rilevate con olio avente viscosità cinematica 30 cst, densità 0,86 kg/dm3 e Δp=0,03 bar.

\* Flow rates measured with oil of 30 cst kinematic viscosity, 0,86 kg/dm3 density and Δp=0,03 bar.

• Compatibilità con fluidi: oli minerali (HH-HL-HM-HR-HV-HG) e fluidi sintetici (HS-HFDR-HFDU-HFDS).

• Fluid compatibility: mineral oil (HH-HL-HM-HR-HV-HG) and synthetic fluids (HS-HFDR-HFDU-HFDS).

## COME ORDINARE UN FILTRO COMPLETO:

HOW TO ORDER A COMPLETE FILTER:

FI	1	.	10	M30																															
<b>Serie</b>	<b>Filettatura</b> Connection	<b>Dimensioni</b> Dimensions	<b>Elemento filtrante</b> Filter element	<b>By-Pass</b>																															
<b>FI</b>	<table border="1"> <tr><td><b>1</b></td><td>3/8" bspp</td></tr> <tr><td><b>2</b></td><td>1/2" bspp</td></tr> <tr><td><b>3</b></td><td>3/4" bspp</td></tr> <tr><td><b>4</b></td><td>1" bspp</td></tr> <tr><td><b>5</b></td><td>1" 1/4 bspp</td></tr> <tr><td><b>6</b></td><td>1" 1/2 bspp</td></tr> <tr><td><b>7</b></td><td>2" bspp</td></tr> <tr><td><b>8</b></td><td>2" 1/2 bspp</td></tr> <tr><td><b>9</b></td><td>3" bspp</td></tr> </table>	<b>1</b>	3/8" bspp	<b>2</b>	1/2" bspp	<b>3</b>	3/4" bspp	<b>4</b>	1" bspp	<b>5</b>	1" 1/4 bspp	<b>6</b>	1" 1/2 bspp	<b>7</b>	2" bspp	<b>8</b>	2" 1/2 bspp	<b>9</b>	3" bspp	vedi tabella see table	<table border="1"> <tr><td><b>M30</b></td><td>30μ Carta 30μ Paper</td></tr> <tr><td><b>M60</b></td><td>60μ Tela met. 60μ metal mesh</td></tr> <tr><td><b>M90</b></td><td>90μ Tela met. 90μ metal mesh</td></tr> <tr><td><b>MD5</b></td><td>250μ Tela met. 250μ metal mesh</td></tr> </table>	<b>M30</b>	30μ Carta 30μ Paper	<b>M60</b>	60μ Tela met. 60μ metal mesh	<b>M90</b>	90μ Tela met. 90μ metal mesh	<b>MD5</b>	250μ Tela met. 250μ metal mesh	<table border="1"> <tr><td></td><td>Senza By-pass Without By-pass</td></tr> <tr><td><b>B</b></td><td>Con By-pass apertura 0,3 bar With By-pass opening 0,3 bar</td></tr> </table>		Senza By-pass Without By-pass	<b>B</b>	Con By-pass apertura 0,3 bar With By-pass opening 0,3 bar	
<b>1</b>	3/8" bspp																																		
<b>2</b>	1/2" bspp																																		
<b>3</b>	3/4" bspp																																		
<b>4</b>	1" bspp																																		
<b>5</b>	1" 1/4 bspp																																		
<b>6</b>	1" 1/2 bspp																																		
<b>7</b>	2" bspp																																		
<b>8</b>	2" 1/2 bspp																																		
<b>9</b>	3" bspp																																		
<b>M30</b>	30μ Carta 30μ Paper																																		
<b>M60</b>	60μ Tela met. 60μ metal mesh																																		
<b>M90</b>	90μ Tela met. 90μ metal mesh																																		
<b>MD5</b>	250μ Tela met. 250μ metal mesh																																		
	Senza By-pass Without By-pass																																		
<b>B</b>	Con By-pass apertura 0,3 bar With By-pass opening 0,3 bar																																		



# SERIE FR/FRP

## IT Filtri aspirazione olio idraulico immersi nel serbatoio con attacco filettato (versione metallo o plastica)

### CARATTERISTICHE TECNICHE:

- Attacco filettato: Serie FR acciaio zincato / Serie FRP nylon caricato vetro.
- Fondello: acciaio zincato.
- Tubo interno: lamiera forata in acciaio zincato.
- Attacchi disponibili standard: da 3/8" a 3" ("bspp"). "Npt" o altre filettature su richiesta.
- Elementi filtranti disponibili standard: Serie FR 160 Micron nom. tela metallica. Serie FRP 125 Micron nom. tela metallica. Altre filtrazioni su richiesta.
- By-pass: fornibile su richiesta (apertura 0,3 bar).
- Temperatura esercizio: da -30°C a +110°C.
- Pressione collasso: 1 bar.
- Test eseguiti secondo normative: ISO 2941 / ISO 3724 / ISO 3968.

## EN Threaded tank-immersed suction oil filters (metal or plastic version)

### TECHNICAL FEATURES:

- Threaded cap: FR Series galvanized steel / FRP Series glass-filled nylon.
- End cap: galvanized steel.
- Inner pipe: galvanized perforated plate.
- Standard available threads: from 3/8" to 3" ("bspp"). "Npt" or other threads available upon request.
- Standard available filter elements: FR Series 160 Micron nom. wire mesh. FRP Series 125 Micron nom. metal mesh. Other filtrations upon request.
- By-pass: available upon request (0,3 bar opening).
- Working temperature: from -30°C to +110°C.
- Collapse pressure: 1 bar.
- Tested according standards: ISO 2941 / ISO 3724 / ISO 3968.

## D Eingetauchsaugfilter mit Gewindeanschluß (Metall oder Kunststoff Ausführung)

### TECHNISCHE DATEN:

- Anschlußkappe: Serie FR verzinktem Stahl / Serie FRP Nylon-Glasverstärkt.
- Endkappe: verzinktem Stahl.
- Innen Rohr: verzinktem Lochblech.
- Standard Anschlußgewinde: von 3/8" bis 3" („bspp“). „Npt“ oder weitere Gewinden auf Anfrage erhältlich.
- Standard Filterelemente: Serie FR 160 Mikron nom. Drahtgewebe. Serie FRP 125 Mikron nom. Drahtgewebe. Weitere Materialien auf Anfrage erhältlich.
- By-pass Ventil: auf Anfrage (0,3 bar Eröffnung).
- Betriebstemperatur: von -30°C bis +110°C.
- Kollapsdrücke: 1 bar.
- Test nach Normen: ISO 2941 / ISO 3724 / ISO 3968.

## FR Crepines d'aspiration (version métallique ou plastique)

### CARACTERISTIQUES TECHNIQUES:

- Flasque de connexion: Serie FR acier zingué / Serie FRP nylon reinf. Avec fibre verre.
- Flasque: acier zingué.
- Tube central: toles perforée en acier zingué.
- Raccordements standard: de 3/8" à 3" („bspp“). „Npt“ ou autres filetages disponibles sur demande.
- Eléments filtrants: Serie FR 160 Micron nom. Toile metallica. Serie FR 125 Micron nom. Toile metallica. Autres matériaux disponibles sur demande.
- Clapet By-pass: sur demande (ouverture 0,3 bar).
- Temperature de travaille: de -30°C à +110°C.
- Pression d'écrasement: 1 bar.
- Test selon standards: ISO 2941 / ISO 3724 / ISO 3968.

## ES Filtros en aspiración sumergidos (versión metálica o de plástico)

### CARACTERÍSTICAS TÉCNICAS:

- Conexión: Serie FR en acero cincado / Serie FRP Nylon carga fibra de vidrio.
- Fondo: acero cincado.
- Tubo interno: chapa perforada en acero cincado.
- Conexiones disponibles estandar: de 3/8" a 3" („bspp“). „Npt“ o otras conexiones bajo pedido.
- Elemento filtrante disponible estandar: Serie FR 160 micras nom. tela metálica. Serie FRP 125 micras nom. tela metálica. Otras filtraciones bajo pedido.
- By-pass: Bajo pedido (apertura 0,3bar).
- Temperatura de ejercicio: de -30°C a +110°C.
- Presión de colapso: 1 bar
- Controles seguidos según normativas: ISO 2941 / ISO 3724 / ISO 3968.

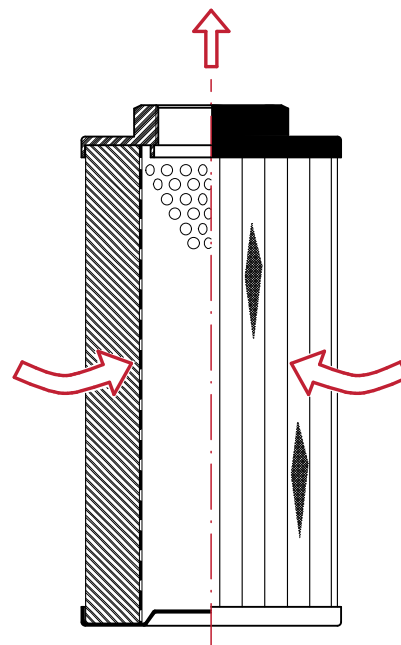
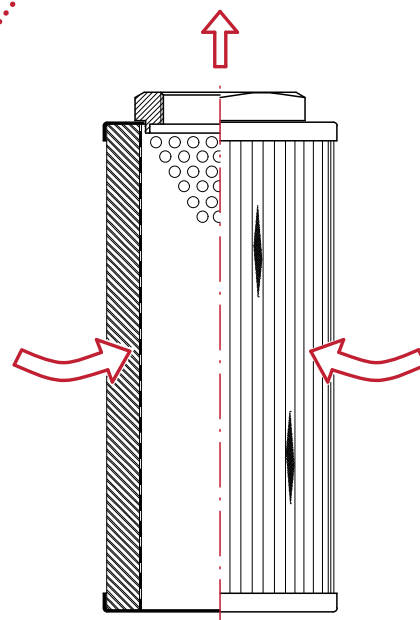

# FR

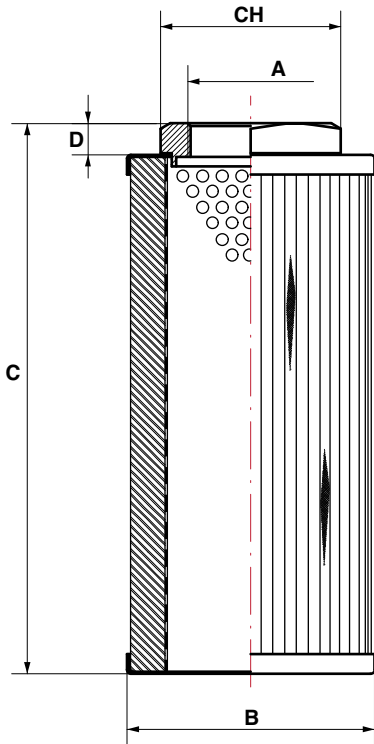

## VERSIONE ATTACCO IN METALLO • METALLIC CONNECTION VERSION

Mod.	A*	B	C	D	CH	μ	Portate l/min.* Flow l/min.**
FR1.04482	3/8"	45	40	8	22	160 μ	5
FR1.06600	3/8"	45	55	8	22	160 μ	8
FR1.04483	3/8"	45	75	8	22	160 μ	10
FR3.04484	1/2"	45	105	8	30	160 μ	15
FR2.04485	3/4"	63	110	8	36	160 μ	25
FR8.04486	1"	63	140	9	46	160 μ	50
FR8.06625	1"	89	144	9	46	160 μ	80
FR8.04487	1" 1/4	89	125	10	60	160 μ	75
FR8.04488	1" 1/2	89	145	10	60	160 μ	100
FR8.04489	1" 1/2	89	200	10	60	160 μ	130
FR8.04490	2"	89	260	10	75	160 μ	180
FR8.04491	2"	140	150	10	75	160 μ	225
FR8.04492	2" 1/2	140	215	16	95	160 μ	350
FR8.04493	3"	150	270	26	100	160 μ	500

# FRP

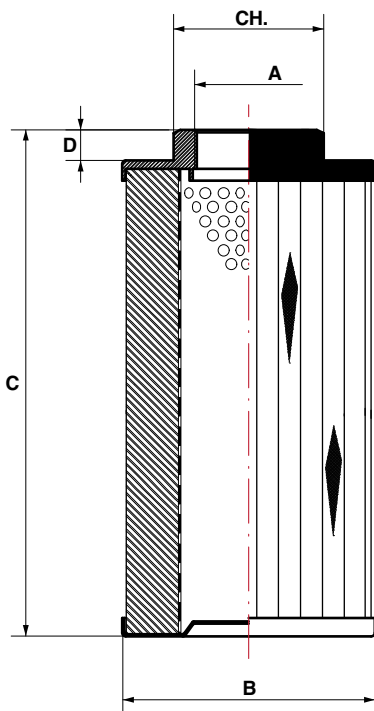

## VERSIONE ATTACCO IN PLASTICA • PLASTIC CONNECTION VERSION

Mod.	A*	B	C	D	CH	μ	Portate l/min.* Flow l/min.**
FRP1.07400	3/8"	46	40	18	30	125 μ	5
FRP1.07401	3/8"	46	55	18	30	125 μ	8
FRP1.07402	3/8"	46	75	18	30	125 μ	10
FRP2.07403	1/2"	46	105	18	30	125 μ	15
FRP3.07404	3/4"	64	110	20	36	125 μ	25
FRP4.07405	1"	64	140	21	46	125 μ	50
FRP4.07406	1"	86	140	25	60	125 μ	80
FRP5.07407	1" 1/4	86	140	25	60	125 μ	75
FRP6.07408	1" 1/2	86	140	25	60	125 μ	100
FRP6.07409	1" 1/2	86	200	25	60	125 μ	130
FRP7.07410	2"	86	260	26	70	125 μ	180
FRP7.07411	2"	150	150	28	70	125 μ	225
FRP8.07412	2" 1/2	150	210	33	90	125 μ	350
FRP9.07413	3"	150	270	33	100	125 μ	500

- Per versione con By-pass aggiungere "B" alla fine del codice
- Add "B" to code's end for By-pass version.

\* Filettatura standard "bspp". Eventuale filettatura "npt" o speciale su richiesta.  
\* Standard threads "bspp". "Npt" or special threads upon request.

\*\* Portate rilevate con olio avente viscosità cinematica 30 cst, densità 0,86 kg/dm<sup>3</sup> e Δp=0,03 bar.

\*\* Flow rates measured with oil of 30 cst kinematic viscosity, 0,86 kg/dm<sup>3</sup> density and Δp=0,03 bar.

- Compatibilità con fluidi: oli minerali (HH-HL-HM-HR-HV-HG) e fluidi sintetici (HS-HFDR-HFDU-HFDS).
- Fluid compatibility: mineral oil (HH-HL-HM-HR-HV-HG) and synthetic fluids (HS-HFDR-HFDU-HFDS).



# SERIE FR

**IT** Filtri aspirazione olio idraulico immersi nel serbatoio con attacco filettato, specifici per mini centraline e piccole portate (ideali per spazi ridotti).

## CARATTERISTICHE TECNICHE:

- Fondelli + attacchi: acciaio zincato.
- Tubo interno (ove presente): lamiera forata in acciaio zincato.
- Attacchi disponibili standard: da 1/4" a 1" ("bspp"). "Npt" o altre filettature su richiesta.
- Elementi filtranti disponibili standard: 60-90-120-250-500 Micron nom. Tela metallica. Altre filtrazioni su richiesta.
- Tubi pescaggio fornibili su richiesta.
- Temperatura esercizio: da -30°C a +110°C.
- Pressione collasso: 1 bar.
- Test eseguiti secondo normative: ISO 2941 / ISO 3724 / ISO 3968.

**EN** Threaded tank-immersed suction oil filters, specific for mini powerpacks and small flow rates (ideal for narrow spaces).

## TECHNICAL FEATURES:

- Connections + caps: galvanized steel.
- Inner pipe (where present): galvanized perforated plate.
- Standard available threads: from 1/4" to 1" ("bspp"). "Npt" or other threads available upon request.
- Standard available filter elements: 60-90-120-250-500 Micron nom. wire mesh. Other filtrations upon request.
- Suction pipes available upon request.
- Working temperature: from -30°C to +110°C.
- Collapse pressure: 1 bar.
- Tested according standards: ISO 2941 / ISO 3724 / ISO 3968.

**D** Eingetauchsaugfilter mit Gewindeanschluß, spezifisch für Miniaggregate und kleine Durchflüsse (ideal für enge Räume).

## TECHNISCHE DATEN:

- Endkappe + Anschluß: verzinktem Stahl.
- Innen Rohr (falls vorhanden): verzinktem Lochblech.
- Standard Anschlußgewinde: von 1/4" bis 1" („bspp“). „npt“ oder weitere Gewinden auf Anfrage erhältlich.
- Standard Filterelemente: 60-90-120-250-500 Mikron nom. Drahtgewebe. Weitere Materialien auf Anfrage erhältlich.
- Saugleitungen auf Anfrage erhältlich.
- Betriebstemperatur: von -30°C bis +110°C.
- Kollapsdrücke: 1 bar.
- Test nach Normen: ISO 2941 / ISO 3724 / ISO 3968.

**FR** Crepines d'aspiration, spécifiques pour mini centrales et petits débits (idéales pour espaces étroits).

## CARACTERISTIQUES TECHNIQUES:

- Flasques + connexions: acier zingué.
- Tube central (si present): toles perforée en acier zingué.
- Raccordements standard: de 1/4" à 1" („bspp“). „Npt“ ou autres filetages disponibles sur demande.
- Eléments filtrants standard: 60-90-120-250-500 Micron nom. Toile métallique. Autres matériaux disponibles sur demande.
- Tubes d'aspiration disponibles sur demande.
- Temperature de travaille: de -30°C à +110°C.
- Pression d'écrasement: 1 bar.
- Test selon standards: ISO 2941 / ISO 3724 / ISO 3968.

**ES** Filtros en aspiración sumergidos, específicas para minicentrales y bajas caudales (ideales para espacios reducidos).

## CARACTERÍSTICAS TÉCNICAS:

- Fondos y conexiones: acero cincado.
- Tubo interno (si presente): chapa perforada en acero cincado.
- Conexiones disponibles estandar: de 1/4" a 1" („bspp“). „Npt“ o otras conexiones bajo pedido.
- Elemento filtrante disponible estandar: 60-90-120-250-500 micras nom. tela metálica. Otras filtraciones bajo pedido.
- Tubos aspiración disponibles bajo pedido.
- Temperatura de ejercicio: de -30°C a +110°C.
- Presión de colapso: 1 bar.
- Controles seguidos según normativas: ISO 2941 / ISO 3724 / ISO 3968.

PER MINICENTRALINE E PICCOLE PORTATE  
FOR MINI POWERPACKS AND SMALL FLOW RATES  
FÜR MINIAGGREGATE UND KLEINE DURCHFLÜSSE  
POUR MINI CENTRALES ET PETITS DÉBITS  
POUR MINICENTRALES Y BAJOS CAUDALES

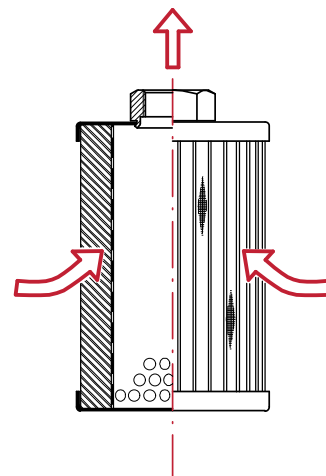
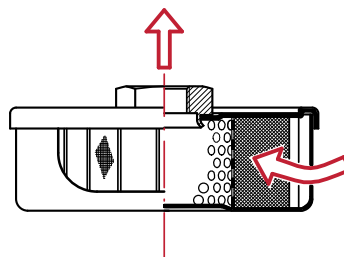
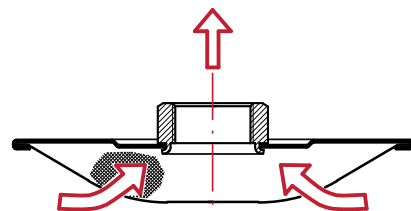

## FILTRI IN ASPIRAZIONE PER MINICENTRALINE SUCTION FILTERS FOR MINI POWERPACKS

**TIPO 1 - TYPE 1  
(LISCIO - PLAIN)**

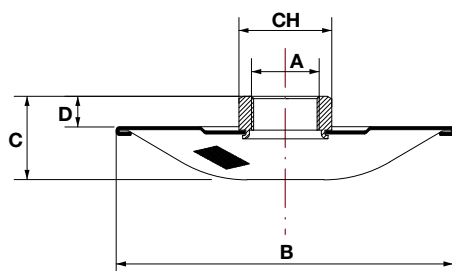

**TIPO 2 - TYPE 2  
(PLISSETTATO - PLEATED)**

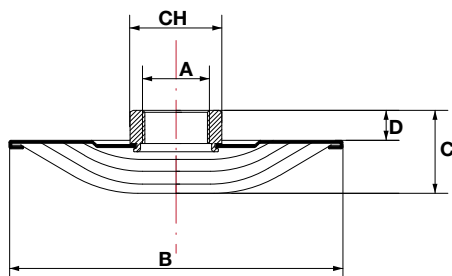

Mod.	DIMENSIONI - DIMENSIONS mm					Superficie filtrante cm <sup>2</sup> Filtering surface cm <sup>2</sup> (Tipo - Type)	Elemento filtrante Filter element	Portata l/min.** Flow l/min.**
	A	B	C	D	CH			
FR5.06694	1/4" bspp	32	13	6	22	9 (1)	90μ Reps FeZn	4
FR1.06692	3/8" bspp	32	15	8	22	9 (1)	90μ Reps FeZn	5
FR5.01752	1/4" bspp	63	14	5	22	30 (1)	90μ Reps FeZn	7
FR4.03500	M 12x1	63	16	7	22	30 (1)	90μ Reps FeZn	7
FR1.02319	3/8" bspp	63	16	7	22	30 (1)	90μ Reps FeZn	10
FR1.04462	3/8" npt	63	17	7	22	45 (2)	90μ Reps FeZn	12
FR5.03546	1/4" bspp	63	14	5	22	30 (1)	250μ Reps FeZn	9
FR1.04386	3/8" bspp	63	16	7	22	30 (1)	200μ Reps FeZn	11
FR5.04465	1/4" bspp	63	14	5	22	30 (1)	250μ Reps FeZn	9
FR1.03570	3/8" bspp	63	16	7	22	30 (1)	250μ Lam Inox	12
FR3.04387	1/2" bspp	63	16	7	30	30 (1)	250μ Lam Inox	18
FR5.03503	1/4" bspp	63	17	7	22	45 (2)	90μ Reps FeZn	9
FR5.04265	1/4" bspp	63	17	7	22	45 (2)	60μ Reps FeZn	7
FR1.02396	3/8" bspp	63	17	7	22	45 (2)	90μ Reps FeZn	12
FR1.01775	3/8" bspp	63	20	8	22	120 (2)	250μ Reps FeZn	13
FR5.03506	1/4" bspp	80	17	5	22	53 (1)	90μ Reps FeZn	7
FR1.02394	3/8" bspp	80	17	7	22	53 (1)	250μ Reps FeZn	13
FR1.03581	3/8" bspp	80	17	7	22	53 (1)	200μ Reps FeZn	13
FR1.04216	3/8" bspp	80	17	7	22	200 (2)	60μ Reps Inox	6
FR1.04398	3/8" bspp	80	17	7	22	53 (1)	90μ Reps FeZn	12
FR4.03502	M 12x1	80	17	7	22	53 (1)	90μ Reps FeZn	10
FR4.02386	M 12x1	80	17	7	22	53 (1)	200μ Reps FeZn	13
FR1.03571	3/8" bspp	80	21	7	22	100 (2)	250μ Lam Inox	14
FR5.02395	1/4" bspp	80	23	5	22	200 (2)	90μ Reps FeZn	12
FR4.02393	M 12x1	80	25	7	22	200 (2)	90μ Reps FeZn	12
FR1.02392	3/8" bspp	80	25	7	22	200 (2)	90μ Reps FeZn	14

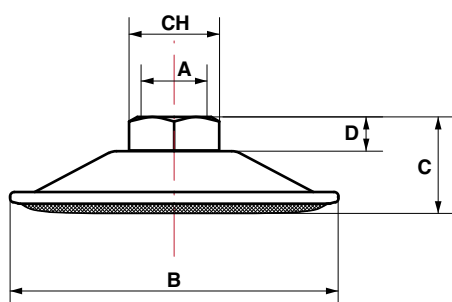

## FILTRI IN ASPIRAZIONE PER MINICENTRALINE FORMA A CAMPANA SUCTION FILTERS FOR MINI POWERPACKS BELL SHAPED

Mod.	DIMENSIONI - DIMENSIONS mm					Superficie filtrante cm <sup>2</sup> Filtering surface cm <sup>2</sup>	Elemento filtrante Filter element	Portata l/min.** Flow l/min.**
	A	B	C	D	CH			
FR1.04391	3/8" bspp	80	23,5	8	22	65	90μ Reps FeZn	12

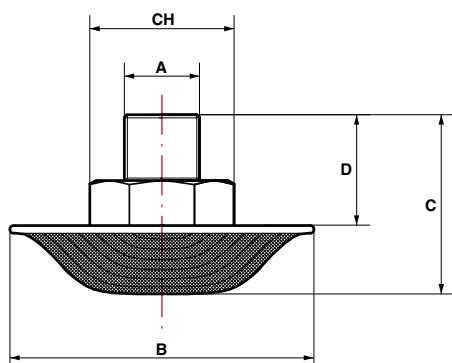

## FILTRI IN ASPIRAZIONE PER MINICENTRALINE ATTACCO MASCHIO SUCTION FILTERS FOR MINI POWERPACKS

Mod.	DIMENSIONI - DIMENSIONS mm					Superficie filtrante cm <sup>2</sup> Filtering surface cm <sup>2</sup>	Elemento filtrante Filter element	Portata l/min.** Flow l/min.**
	A	B	C	D	CH			
FR5.04434	1/4" bspp	63	27,5	17,5	19	45	90μ Reps FeZn	12
FR1.02374	3/8" bspp	80	33	20,5	22	53	250μ Reps FeZn	15
FR1.03572	3/8" bspp	80	35	20,5	22	200	250μ Lam Inox	20
FR3.04355	1/2" bspp	80	43	26,5	25	200	90μ Reps FeZn	22
FR2.04356	3/4" bspp	80	43	26	36	200	90μ Reps FeZn	28
FR8.04357	1" bspp	80	52	35,5	46	200	90μ Reps FeZn	32
FR6.04332	∅ i 30	80	42	25	-	200	90μ Reps FeZn	38



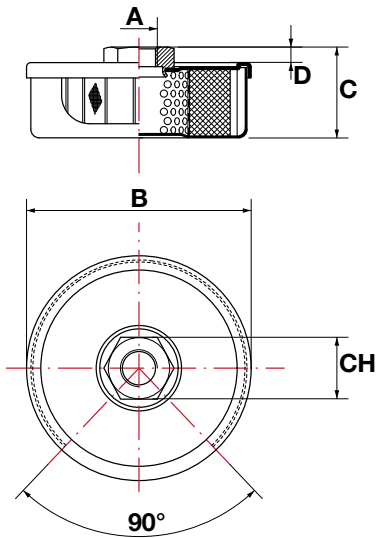

### FILTRO IN ASPIRAZIONE SCHERMATO ATTACCO FEMMINA FEMALE THREADED SCREENED SUCTION FILTER

Mod.	DIMENSIONI - DIMENSIONS mm					Superficie filtrante cm <sup>2</sup> Filtering surface cm <sup>2</sup>	Elemento filtrante Filter element	Portata l/min.** Flow l/min.**
	A	B	C	D	CH			
<b>FR5.01766</b>	1/4" bspp	80	26	6	22	70	200μ Repts FeZn	12
<b>FR5.02345</b>	1/4" bspp	80	32	6	22	100	90μ Repts FeZn	13
<b>FR1.01329</b>	3/8" bspp	80	32	8	22	100	90μ Repts FeZn	14
<b>FR1.01328</b>	3/8" bspp	80	32	8	22	200	90μ Repts FeZn	16

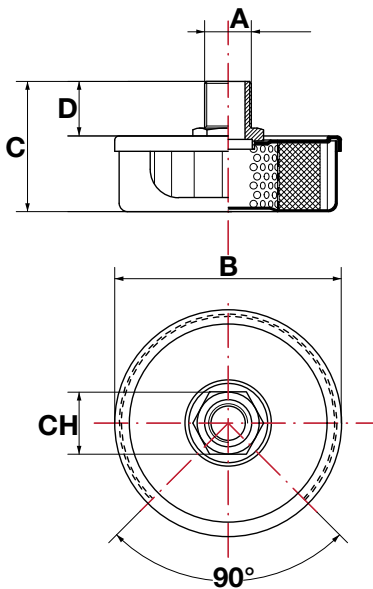

### FILTRO IN ASPIRAZIONE SCHERMATO ATTACCO MASCHIO SCREENED SUCTION FILTER MALE THREADED

Mod.	DIMENSIONI - DIMENSIONS mm					Superficie filtrante cm <sup>2</sup> Filtering surface cm <sup>2</sup>	Elemento filtrante Filter element	Portata l/min.** Flow l/min.**
	A	B	C	D	CH			
<b>FR1.01330</b>	3/8" bspt	80	47	21	22	100	90μ Repts FeZn	14
<b>**FR1.03588</b>	3/8" bspt	80	47	21	22	100	90μ Repts FeZn	14
<b>*FR1.03522</b>	3/8" bspt	80	47	21	22	200	90μ Repts FeZn	16
<b>*FR5.04231</b>	1/4" bspp	32	39	18	19	34	90μ Repts FeZn	5
<b>FR7.02348</b>	3/8" bspt	80	47	21	22	100	60μ Repts Inox	10
<b>*FR7.02380</b>	3/8" bspt	80	47	21	22	100	60μ Repts Inox	10

\* non schermato / not screened

\*\* attacco eccentrico / cam connection

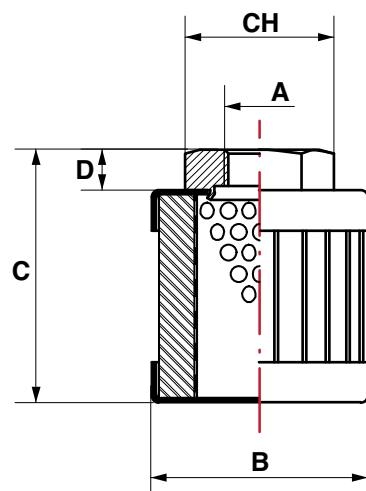

### FILTRO IN ASPIRAZIONE 1/4" BSPP SUCTION FILTER 1/4" BSPP

Mod.	DIMENSIONI - DIMENSIONS mm					Superficie filtrante cm <sup>2</sup> Filtering surface cm <sup>2</sup>	Elemento filtrante Filter element	Portata l/min.** Flow l/min.**
	A	B	C	D	CH			
<b>FR5.01759</b>	1/4"	32	27	6	22	34	90μ Repts FeZn	5
<b>FR5.02361</b>	1/4"	32	37	6	22	52	90μ Repts FeZn	6
<b>FR5.04289</b>	1/4"	32	50	6	22	44	90μ Repts FeZn	6
<b>FR5.01373</b>	1/4"	32	56	6	22	78	90μ Repts FeZn	7
<b>FR5.04430</b>	1/4"	45	56	6	22	127	90μ Repts FeZn	11
<b>FR5.02334</b>	1/4"	50	32	6	22	100	90μ Repts FeZn	10
<b>FR5.04238</b>	1/4"	50	87	6	22	216	90μ Repts FeZn	13
<b>FR5.04243</b>	1/4"	50	87	6	22	216	60μ Repts Inox	7

### FILTRO IN ASPIRAZIONE 3/8" BSPP - SUCTION FILTER 3/8" BSPP

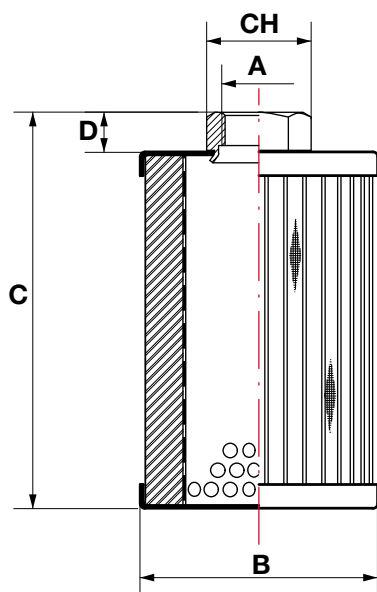

Mod.	DIMENSIONI - DIMENSIONS mm					Superficie filtrante cm <sup>2</sup> Filtering surface cm <sup>2</sup>	Elemento filtrante Filter element	Portata l/min.** Flow l/min.**
	A	B	C	D	CH			
FR1.02355	3/8"	32	29	8	22	34	90µ Repls FeZn	10
FR1.03583	3/8"	32	29	8	22	34	200µ Repls FeZn	8
FR1.02360	3/8"	32	39	8	22	50	90µ Repls FeZn	12
FR1.04283	3/8"	32	59	8	22	88	60µ Repls Inox	8
FR1.01303	3/8"	32	59	8	22	78	90µ Repls FeZn	14
FR7.04455	3/8"	32	59	8	22	78	250µ Repls Inox	15
FR1.02353	3/8"	32	75	8	22	120	90µ Repls FeZn	14
FR1.03590	3/8"	45	78	8	22	190	90µ Repls FeZn	18
FR1.03566	3/8"	45	78	8	22	190	120µ St. Steel Mesh	20
FR1.02306	3/8"	45	103	8	22	260	120µ St. Steel Mesh	22
FR1.01318	3/8"	50	35	8	22	96	90µ Repls FeZn	14
FR1.01308	3/8"	50	75	8	22	200	90µ Repls FeZn	16
FR1.04384	3/8"	50	84	8	22	200	60µ Repls Inox	13
FR1.03564	3/8"	50	105	8	22	430	60µ Repls Inox	15
FR1.01340	3/8"	80	34	8	22	100	90µ Repls FeZn	14
FR1.01343	3/8"	80	34	8	22	200	90µ Repls FeZn	16

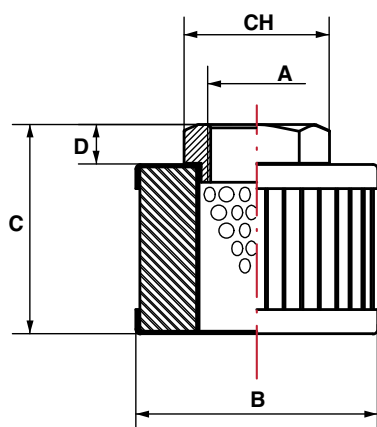

### FILTRO IN ASPIRAZIONE 1/2" BSPP SUCTION FILTER 1/2" BSPP

Mod.	DIMENSIONI - DIMENSIONS mm					Superficie filtrante cm <sup>2</sup> Filtering surface cm <sup>2</sup>	Elemento filtrante Filter element	Portata l/min.** Flow l/min.**
	A	B	C	D	CH			
FR3.04416	1/2"	42	105	8	30	390	90µ Repls FeZn	22
FR3.01347	1/2"	50	75	8	30	200	90µ Repls FeZn	23
FR3.04361	1/2"	50	80	8	30	237	250µ Repls FeZn	25
FR3.04307	1/2"	50	89	8	30	237	250µ Lam Inox	26
*FR3.02367	1/2"	50	130	8	30	320	90µ Repls FeZn	35
FR3.03518	1/2"	63	103	8	30	350	120µ St. Steel Mesh	26
FR3.02333	1/2"	100	58	8	30	300	250µ Repls FeZn	25

\* in scarico / drain filter

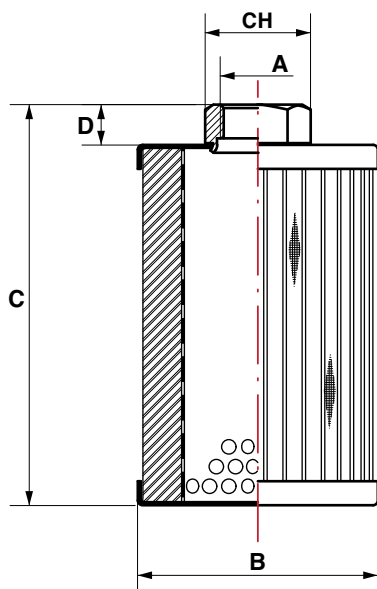

### FILTRO IN ASPIRAZIONE 3/4" BSPP SUCTION FILTER 3/4" BSPP

Mod.	DIMENSIONI - DIMENSIONS mm					Superficie filtrante cm <sup>2</sup> Filtering surface cm <sup>2</sup>	Elemento filtrante Filter element	Portata l/min.** Flow l/min.**
	A	B	C	D	CH			
FR2.02305	3/4"	63	103	8	36	350	150µ Lam Inox	40
FR2.04230	3/4"	63	103	8	36	350	500µ Lam Inox	60
FR2.02354	3/4"	63	128	8	36	410	150µ Lam Inox	50
FR2.04203	3/4"	63	160	8	36	675	60µ Repls Inox	30



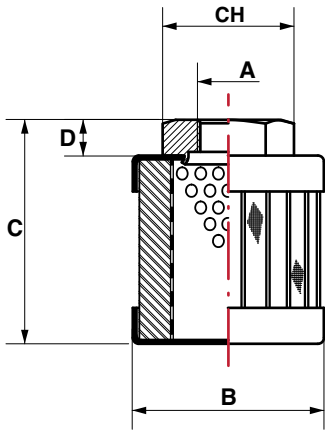

### FILTRO IN ASPIRAZIONE M 12X1 SUCTION FILTER M 12X1

Mod.	DIMENSIONI - DIMENSIONS mm					Superficie filtrante cm <sup>2</sup> Filtering surface cm <sup>2</sup>	Elemento filtrante Filter element	Portata l/min.** Flow l/min.**
	A	B	C	D	CH			
FR4.01342	12x1	32	29	8	22	34	90μ Repts FeZn	5
FR4.01336	12x1	32	58	8	22	78	90μ Repts FeZn	7
FR4.01335	12x1	80	34	8	22	100	90μ Repts FeZn	10
FR4.01333	12x1	80	34	8	22	200	90μ Repts FeZn	12

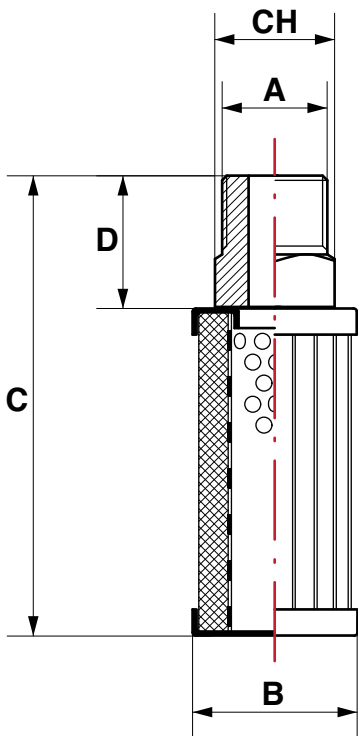

### FILTRO OLIO IDRAULICO IN ASPIRAZIONE ATTACCO MASCHIO 3/8" BSPT HYDRAULIC OIL SUCTION FILTER MALE CONN. 3/8" BSPT

Mod.	DIMENSIONI - DIMENSIONS mm					Superficie filtrante cm <sup>2</sup> Filtering surface cm <sup>2</sup>	Elemento filtrante Filter element	Portata l/min.** Flow l/min.**
	A	B	C	D	CH			
*FR1.01779	3/8"	26	64	20	17	56	90μ Repts FeZn	20
FR1.02352	3/8"	26	70	20	17	65	90μ Repts FeZn	21

\* schermato 180° / screened 180°

\*\* Portate rilevate con olio avente viscosità cinematica 30 cst, densità 0,86 kg/dm<sup>3</sup> e  $\Delta p=0,03$  bar.

\*\* Flow rates measured with oil of 30 cst kinematic viscosity, 0,86 kg/dm<sup>3</sup> density and  $\Delta p=0,03$  bar.

• Compatibilità con fluidi: oli minerali (HH-HL-HM-HR-HV-HG) e fluidi sintetici (HS-HFDR-HFDU-HFDS).

• Fluid compatibility: mineral oil (HH-HL-HM-HR-HV-HG) and synthetic fluids (HS-HFDR-HFDU-HFDS).

# SERIE XFS

**IT** Filtri aspirazione con doppio filetto avvitabili direttamente al serbatoio (ideali per spazi ridotti es. Serbatoi verticali macchine spaccalegna).

**CARATTERISTICHE TECNICHE:**

- Fondello + dado attacco: acciaio zincato.
- Attacchi disponibili standard (maschio/femmina): da 1/2" a 1" ("bspp"). "Npt" o altre filettature su richiesta.
- Elementi filtranti disponibili standard: 90-250-400 Micron nom. tela metallica. Altre filtrazioni su richiesta.
- Temperatura esercizio: da -30°C a +110°C.
- Pressione collasso: 1 bar.
- Test eseguiti secondo normative: ISO 2941 / ISO 3724 / ISO 3968.

**EN** Double thread suction oil filters, to screw directly to oil tank (ideal for narrow spaces f.e. vertical tanks for log-splitters).

**TECHNICAL FEATURES:**

- End cap + threaded nut: galvanized steel.
- Standard available threads (male/female): from 1/2" to 1" ("bspp"). "Npt" or other threads available upon request.
- Standard available filter elements: 90-250-400 Micron nom. wire mesh. Other filtrations upon request.
- Working temperature: from -30°C to +110°C.
- Collapse pressure: 1 bar.
- Tested according standards: ISO 2941 / ISO 3724 / ISO 3968.

**D** Eingetauchsaugfilter mit Doppelgewindeanschluß, zum Schrauben direkt an Öltank (ideal für enge Räume z.B. Vertikaltank für Holzspalter).

**TECHNISCHE DATEN:**

- Endkappe + Anschlußnuß: verzinktem Stahl.
- Standard Anschlußgewinde (Nutm/Feder): von 1/2" bis 1" ("bspp"). „npt“ oder weitere Gewinden auf Anfrage erhältlich.

- Standard Filterelemente: 90-250-400 Mikron nom. Drahtgewebe. Weitere Materialien auf Anfrage erhältlich.
- Betriebstemperatur: von -30°C bis +110°C.
- Kollapsdrücke: 1 bar.
- Test nach Normen: ISO 2941 / ISO 3724 / ISO 3968.

**FR** Crepines d'aspiration avec double filetage, à visser directement au réservoir d'huile (idéal pour espaces étroits p.e. réservoirs verticaux pour fendeuses).

**CARACTERISTIQUES TECHNIQUES:**

- Flasque + écrou connexion: acier zingué.
- Raccordements standard: de 1/2" à 1" ("bspp"). „Npt“ ou autres filetages disponibles sur demande.
- Eléments filtrants standard: 90-250-400 Micron nom. Toile métallique. Autres matériaux disponibles sur demande.
- Temperature de travail: de -30°C à +110°C.
- Pression d'écrasement: 1 bar.
- Test selon standards: ISO 2941 / ISO 3724 / ISO 3968.

**ES** Filtros en aspiración sumergidos, doble rosca, para atornillar directamente al depósito (ideales para espacios reducidos p.e. depósitos verticales para rajadoras de lena).

**CARACTERÍSTICAS TÉCNICAS:**

- Fondo y tuerca conexión (masc/fem): acero cincado.
- Conexiones disponibles estándar: de 1/2" a 1" ("bspp"). „Npt“ o otras conexiones bajo pedido.
- Elemento filtrante disponible estándar: 90-250-400 micras nom. tela metálica. Otras filtraciones bajo pedido.
- Temperatura de ejercicio: de -30°C a +110°C.
- Presión de colapso: 1 bar
- Controles seguidos según normativas: ISO 2941 / ISO 3724 / ISO 3968.

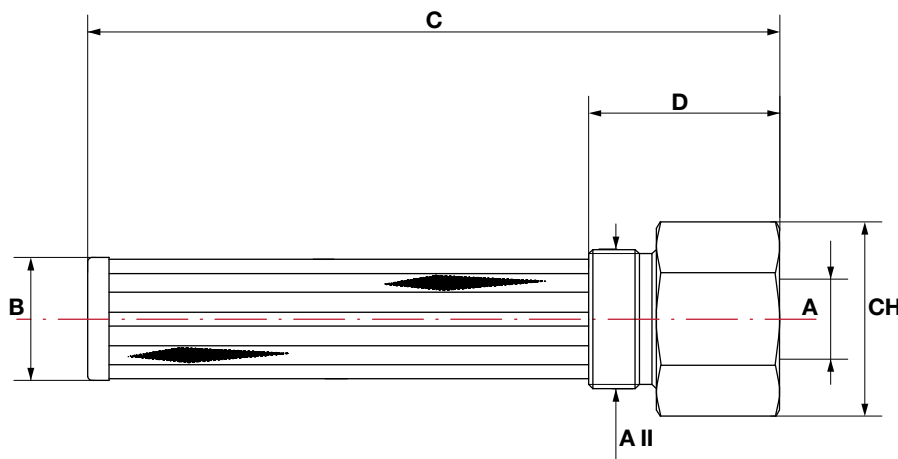

**FILTRO OLIO IDRAULICO IN ASPIRAZIONE 3/8" BSPP DOPPIO FILETTO  
DOUBLE THREAD HYDRAULIC OIL SUCTION FILTER 3/8" BSPP**

Mod.	DIMENSIONI - DIMENSIONS mm						Grado filtrazione Filtering degree	Portata l/min.** Flow l/min.**
	A	A II	B	D	C	CH		
XFS.03918	1/2"	3/4"	21	37	148	30	230/250µ	11
XFS.03912	3/4"	1"	29	45	161	40	90/110µ	19
XFS.03901	1/2"	1"	29	45	145	40	250/270µ	14
XFS.02496	3/4"	1"	29	45	165	40	250/270µ	25
XFS.02492	1/2"	1"	29	45	205	40	250/270µ	14
XFS.02490	1/2"	1"	29	45	165	40	250/270µ	14
XFS.05719	1/2"	1"	29	45	197	40	90/110µ	12
XFS.05736	1/2"	1"	29	45	235	40	400µ	14
XFS.05742	1/2"	1"	29	45	205	40	400µ	14

\*\* Portate rilevate con olio avente viscosità cinematica 30 cst, densità 0,86 kg/dm<sup>3</sup> e Δp=0,03 bar.

\*\* Flow rates measured with oil of 30 cst kinematic viscosity, 0,86 kg/dm<sup>3</sup> density and Δp=0,03 bar.

• Compatibilità con fluidi: oli minerali (HH-HL-HM-HR-HV-HG) e fluidi sintetici (HS-HFDR-HFUDU-HFDS).

• Fluid compatibility: mineral oil (HH-HL-HM-HR-HV-HG) and synthetic fluids (HS-HFDR-HFUDU-HFDS).

## SERIE FB - HL

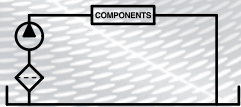

**Filtri in aspirazione**  
**Suction filters**  
**Saugfilter**  
**Filtres d'aspiration**  
**Filtros en aspiracion**

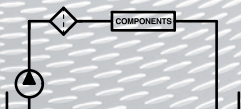

**Filtri in mandata**  
**Delivery filters**  
**Drückfilter**  
**Filtres refoulement**  
**Filtros presion**

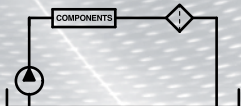

**Filtri sul ritorno**  
**Return-line filters**  
**Rücklauffilter**  
**Filtres retour**  
**Filtros retorno**

GB

**In-line filters**

D

**LeitungsfILTER**

FR

**Filtres en ligne**

ES

**Filtros en linea**



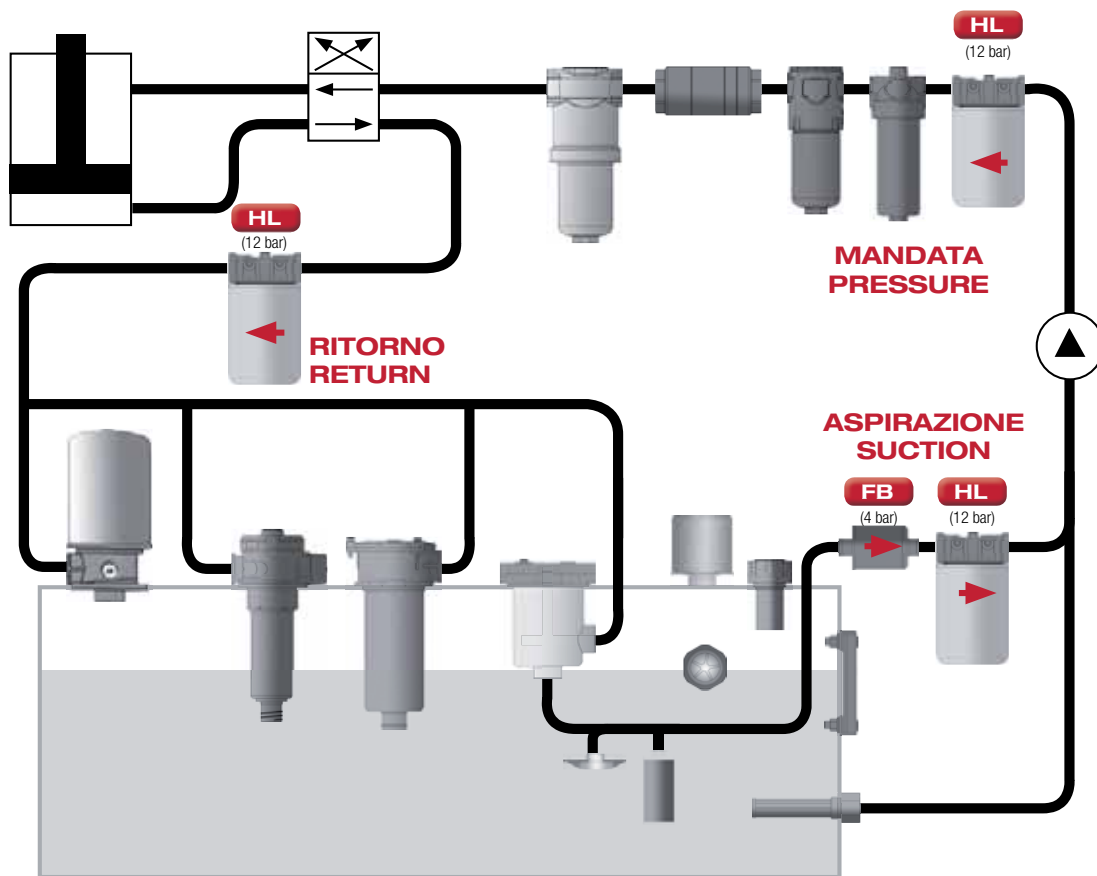

**IT** I filtri serie FB-HL vengono utilizzati per montaggio in linea lungo il circuito oleodinamico a bassa pressione, per proteggere la pompa ed i componenti del sistema dalla contaminazione. I filtri serie FB vengono impiegati in aspirazione mentre i filtri con cartuccia avvitabile (a perdere) serie HL vengono utilizzati sia su linea di aspirazione che ritorno. Si tratta di filtri molto versatili studiati per le più svariate applicazioni: macchine utensili, agricole, movimento terra, veicoli industriali e applicazioni mobili in genere. Sono disponibili diversi modelli per soddisfare tutte le esigenze, dalle piccole alle grandi portate, con diversi elementi filtranti tali da garantire la massima protezione del circuito. Possiamo inoltre realizzare filtri speciali su richiesta del cliente.

**GB** FB-HL series filters are used in-line mounting on low pressure hydraulic circuit, to protect the pump and system components from contamination. FB series filters are used in suction line, while the spin-on filters (disposable) HL series are used on both suction and return line. It is a very versatile series of filters, designed for various applications: tools, agricultural and earthmoving machines, industrial vehicles and mobile applications in general. There are several models to meet all needs, from small to large flows, with different filter elements in order to ensure maximum protection to the circuit. We can also produce special filters upon customer request.

**D** Die Filter der Serie FB-HL werden in Niederdruck-Hydraulikleitungen verbaut, um Pumpe und Systemkomponenten vor Verschmutzung zu schützen. FB-Filter werden in Saugleitungen montiert, während der (Einweg-)Anschraubfilter HL in Saug- und Rücklaufleitungen Verwendung findet. Auch diese Filter bieten vielseitige Einsatzmöglichkeiten, als Beispiele: Werkzeuge, Landwirtschaftliche Fahrzeuge und Maschinen, Baufahrzeuge und -Maschinen, Industriefahrzeuge, allgemeine mobile Anwendungen. Wir bieten Ihnen Modelle in großer Auswahl (kleine bis große Durchflussmengen, verschiedene Filtereinsätze), um auch speziellsten Bedürfnissen gerecht zu werden und Ihre Hydraulikschaltungen jederzeit bestmöglich zu schützen. Und: Wir herstellen auch Filter speziell nach Kundenwunsch.

**FR** La série de filtres FB-HL sont utilisés montés en ligne sur le circuit hydraulique basse pression, pour protéger de la contamination la pompe et les composants du système. Les filtres série FB sont utilisés sur la ligne d'aspiration, tandis que les filtres à visser (jetables) série HL sont utilisés tant sur les lignes d'aspiration que de retour. C'est une série très polyvalent de filtres, conçus pour diverses applications: machines outils, agricoles et de chantiers, véhicules industriels et les applications mobiles en général. Il existe plusieurs modèles pour répondre à tous les besoins, pour débits petits ou grands, avec différents éléments filtrants, afin d'assurer une protection maximale du circuit. Nous pouvons aussi produire filtres spéciaux sur demande du client.

**ES** Los filtros serie FB-HL vienen utilizados para montaje en la linea del circuito hidráulico a baja presión, para proteger la bomba y los componentes del sistema de la contaminación. Los filtros serie FB vienen utilizados en aspiración, mientras los filtros con cartucho roscado (desechables) serie HL vienen utilizados sea en aspiración que en retorno. Se trata de filtros muy versátiles, estudiados para las más variadas aplicaciones: máquina herramienta, agrícola, obra pública, vehiculos industriales y aplicaciones móviles en general. Están disponibles distintos modelos, para satisfacer todas las exigencias, desde pequeños a grandes caudales, con diversos elementos filtrantes tales que garanticen la máxima protección del circuito. Podemos además realizar filtros especiales bajo demanda del cliente.

# SERIE FB

## IT Filtri aspirazione per montaggio in linea su circuiti oleodinamici a bassa pressione.

### CARATTERISTICHE TECNICHE:

- Fondelli + attacchi + corpo esterno: acciaio zincato.
- Cartuccia interna: struttura in acciaio zincato. Elemento filtrante carta o tela inox.
- Attacchi disponibili standard: tubi d.e. da 25 a 50mm. Altri diametri o altre filettature su richiesta.
- Elementi filtranti disponibili standard: 30 Micron nom. Carta / 160 Micron nom. Tela metallica. Altre filtrazioni su richiesta.
- Temperatura esercizio: da -20°C a +100°C.
- Pressione di esercizio: 4 bar.
- Pressione di collaudo: 6 bar.
- Pressione di collasso cartuccia: 5 bar.
- Test eseguiti secondo normative: ISO 2941 / ISO 3724 / ISO 3968.

## EN In-line suction filters for low pressure hydraulic circuits.

### TECHNICAL FEATURES:

- End caps + connections + external body: galvanized steel.
- Inner cartridge: galvanized steel structure. Paper or stainless Steel filtering element.
- Standard available connections: pipes e.d. from 25 to 50mm. Other diameters or threads available upon request.
- Standard available filter elements: 30 Micron nom. paper / 160 Micron nom. wire mesh. Other filtrations upon request.
- Operating temperature: -20°C +100°C.
- Operating pressure: 4 bar.
- Testing pressure: 6 bar.
- Element collapse pressure: 5 bar.
- Tested according standards: ISO 2941 / ISO 3724 / ISO 3968.

## D Leitungsaugfilter für Niederdruck Hydraulikschaltung.

### TECHNISCHE DATEN:

- Endkappe + Anschluß + Außengehäuse: Verzinktem Stahl.
- Innen Patrone: Verzinktem Stahlstruktur. Filterelement aus Papier oder Edelstahlrahtgewebe.
- Standard verfügbaren Anschlüssen: Rohre von 25 bis 50mm. Andere Durchmesser oder weitere Gewinden auf Anfrage erhältlich.
- Standard verfügbaren Filterelemente: 30 Mikron nom. Papier / 160 Mikron nom. Drahtgewebe. Weitere Materialien auf Anfrage erhältlich.
- Betriebstemperatur: von -20°C bis +100°C.
- Betriebsdruck: 4 bar.
- Prüfdruck: 6 bar.
- Patronenkollapsdrücke: 5 bar.
- Test nach Normen: ISO 2941 / ISO 3724 / ISO 3968.

## FR Filtres aspiration en ligne pour circuits hydrauliques à basse pression.

### CARACTERISTIQUES TECHNIQUES:

- Flasques + connexions + corps extérieur: acier zingué.
- Cartouche intérieure: structure en acier zingué. Element filtrant en papier ou toile inox.
- Connexions disponibles standard: de 25 à 50mm. Autres dimetres ou filetages disponibles sur demande.
- Eléments filtrants standard disponibles: 30 Micron nom. Papier / 160 Micron nom. Toile metallica. Autres matériaux disponibles sur demande.
- Temperature de travaille: de -20°C à +100°C.
- Pression de service: 4 bar.
- Pression d'essai: 6 bar.
- Pression d'écrasement élément filtrant: 5 bar.
- Test selon standards: ISO 2941 / ISO 3724 / ISO 3968.

## ES Filtros de aspiración para montaje en linea en circuitos hidráulicos a baja presión.

### CARACTERÍSTICAS TÉCNICAS:

- Fondo + conexiones + cuerpo externo: acero cincado.
- Cartucho interno: estructura en acero cincado. Elemento filtrante papel ó tela inox.
- Conexiones disponibles estándar: tubo d.e. de 25 a 50mm. Otros diametros y roscas bajo pedido.
- Elementos filtrantes disponibles estándar: 30 micron nom. papel / 160 micron nom. tela inox. Otras filtraciones bajo pedido.
- Temperatura de trabajo: de -20°C a +100°C.
- Presión de trabajo: 4 bar.
- Presión de prueba: 6 bar.
- Presión de colapso cartucho: 5 bar
- Test efectuado según normativa: ISO 2941 / ISO 3724 / ISO 3968.

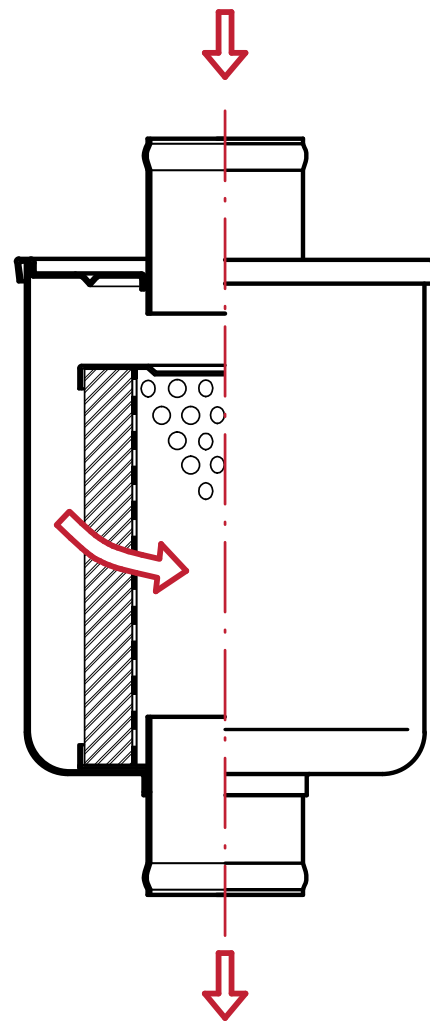

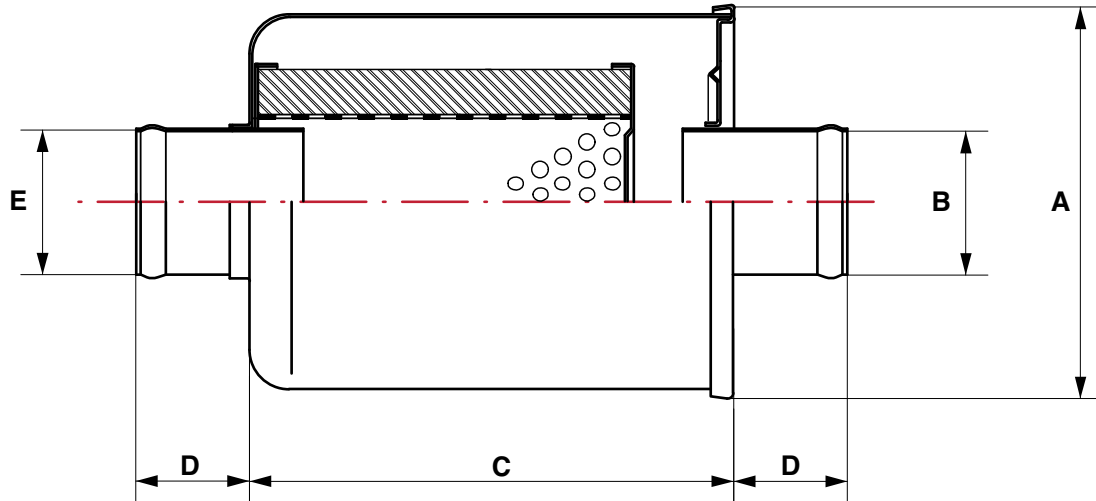

### FILTRI ASPIRAZIONE IN LINEA IN-LINE SUCTION FILTERS

Mod.	DIMENSIONI - DIMENSIONS mm					Elemento filtrante Filter element	Portata l/min.** Flow l/min.**
	A	A II	B	C	D		
<b>FB3.01592</b>	30	30	80	144	23	160 $\mu$ Stainless steel mesh	45
<b>FB3.01593</b>	38	38	80	144	23	160 $\mu$ Stainless steel mesh	65
<b>FB3.01594</b>	35	35	80	144	23	160 $\mu$ Stainless steel mesh	55
<b>FB3.01596</b>	45	45	100	212	42/31	160 $\mu$ Stainless steel mesh	90
<b>FB3.01597</b>	25	25	80	151	27	25 $\mu$ Paper	30
<b>FB3.01599</b>	50	50	80	178	29/24	160 $\mu$ Stainless steel mesh	100
<b>FB3.05097</b>	50	50	80	178	29/24	60 $\mu$ Reps Inox	70
<b>FB3.05102</b>	35	35	80	144	23	60 $\mu$ Reps Inox	52
<b>FB3.05141</b>	40	40	80	206	23	160 $\mu$ Stainless steel mesh	68

\* Tubi standard. Altri diametri o altre filettature su richiesta.

\* Standard pipes. Other diameters or special threads upon request.

\*\* Portate rilevate con olio avente viscosità cinematica 30 cst, densità 0,86 kg/dm<sup>3</sup> e  $\Delta p=0,03$  bar.

\*\* Flow rates measured with oil of 30 cst kinematic viscosity, 0,86 kg/dm<sup>3</sup> density and  $\Delta p=0,03$  bar.

• Compatibilità con fluidi: oli minerali (HH-HL-HM-HR-HV-HG) e fluidi sintetici (HS-HFDR-HFDU-HFDS).

• Fluid compatibility: mineral oil (HH-HL-HM-HR-HV-HG) and synthetic fluids (HS-HFDR-HFDU-HFDS).



# SERIE HL

## IT Filtri avvitabili per montaggio in linea su circuiti oleodinamici a bassa pressione (aspirazione, mandata o ritorno)

### CARATTERISTICHE TECNICHE:

- Testata di supporto: fusione di alluminio.
- Valvola by-pass (testa): Apertura in aspirazione 0,25 bar / sul ritorno 1,7 bar.
- Cartuccia avvitabile: struttura in acciaio zincato. Elemento filtrante in microfibra, carta o tela inox.
- Attacchi disponibili standard: 3/4"bspp (mod. 1-2) o 1"1/4 bspp (mod. 3-4). Filettature speciali su richiesta.
- Elementi filtranti disponibili standard: 3-5-10-25 Micron abs. Microfibra / 10-25 Micron nom. Carta / 60-90 Micron nom. Tela metallica / 30 Micron nom. assorbente acqua. Altre filtrazioni su richiesta.
- Guarnizioni: standard Buna-N. Su richiesta Viton.
- Temperatura esercizio: da -30°C a +110°C.
- Pressione di esercizio: 12 bar. Pressione di scoppio: 25 bar. Pressione di collasso cartuccia: 5 bar.
- Test eseguiti secondo normative: ISO 2941 / ISO 3724 / ISO 3968.

## EN Spin-on filters for in-line low pressure hydraulic circuit mounting (suction, delivery or return).

### TECHNICAL FEATURES:

- Supporting head: aluminium die-casting.
- By-pass valve (head): Opening 0,25 bar in suction / 1,7 bar on return.
- Spin-on element: galvanized steel structure. Filter element in microfiber, paper or wire mesh.
- Standard available threads: 3/4" bspp (mod. 1-2) or 1"1/4 bspp (mod. 3-4). Other threads upon request.
- Standard available filter elements: 3-5-10-25 Micron abs. microfiber / 10-25 Micron nom. paper / 60-90 Micron nom. wire mesh / 30 Micron nom. water absorbing. Other filter elements upon request.
- Seals: Buna-N standard. Viton upon request.
- Operating temperature: -30°C +110°C.
- Operating pressure: 12 bar. Burst pressure: 25 bar. Element collapse pressure: 5 bar.
- Tested according standards: ISO 2941 / ISO 3724 / ISO 3968.

## D LeitungsfILTER für Niederdruck Hydraulikschaltung mit Wechselfiltern (Saug, Druck- und Rücklauf).

### TECHNISCHE DATEN:

- Filterkopf: Aluminium-Druckguss.
- By-pass Ventil (kopf): Eröffnung 0,25 bar in Saug- / 1,7 bar auf Rücklauf.
- Spin-on Element: galvanisierte Stahlkonstruktion. Filterelement in Mikrofaser, Papier - oder Drahtgewebe.
- Standard verfügbaren Anschlüssen: 3 / 4 "bspp (Mod. 1-2) oder 1" 1 / 4 bspp (Mod. 3-4). Weitere Gewinde auf Anfrage erhältlich.
- Standard verfügbaren Filterelemente: 3-5-10-25 Mikron abs. Mikrofaser / 10-25 Mikron nom. Papier / 60-90 Micron nom. Drahtgewebe / 30 Micron nom. Wasserabsorbierendenmedien. Weitere Materialien auf Anfrage erhältlich.
- Dichtungen: Buna-N Standard. Viton auf Wunsch.
- Betriebstemperatur: von -30°C bis +110°C.
- Betriebsdruck: 12 bar. Berstdruck: 25 bar. Patronekollapsdrücke: 5 bar.
- Test nach Normen: ISO 2941 / ISO 3724 / ISO 3968.

## FR Filtres à visser (spin-on) pour montage en ligne sur circuits hydrauliques à basse pression (aspiration, refoulement ou retour)

### CARACTERISTIQUES TECHNIQUES:

- Tête-support: fusion d'aluminium.
- Clapet by-pass (tête): Ouverture en aspiration 0,25 bar / 1,7 bar sur le retour.
- Cartouche à visser: structure en acier galvanisé. Élément filtrant en microfibres, papier ou en toile métallique.
- Connexions standard disponibles: 3/4 "bspp (modèle 1-2) ou 1"1/4 bspp (modèle 3-4). Filetages spéciaux sur demande.
- Éléments filtrants standard disponibles: 3-5-10-25 Micron abs. en microfibres / 10-25 Micron nom. papier / 60-90 Micron nom. Toile métallique / 30 Micron nom. absorption eau. Autres filtrations sur demande.
- Joints: Buna-N standard. Viton sur demande.
- Température de travail: de -30°C à +110°C.
- Pression de service: 12 bar. Pression d'éclatement: 25 bar. Pression d'écrasement élément filtrant: 5 bar.
- Test selon standards: ISO 2941 / ISO 3724 / ISO 3968.

## ES Filtros roscados para montaje en línea en circuitos hidráulicos a baja presión (aspiración, presión ó retorno)

### CARACTERÍSTICAS TÉCNICAS:

- Cabeza de soporte: aluminio fundido.
- Válvula by-pass (cabeza): Apertura en aspiración 0,25 bar / en retorno 1,7 bar.
- Cartucho roscado: cuerpo en acero cincado. Elemento filtrante en microfibra, papel ó tela inox.
- Conexiones disponibles estándar: 3/4"bspp (mod. 1-2) ó 1"1/4bspp (mod. 3-4). Rosca especial bajo pedido.
- Elemento filtrante disponible estándar: 3-5-10-25 micras abs. en Microfibra / 10-25 micras nom. en Papel / 60-90 micras nom. en Tela Metálica / 30 Micron nom. media absorción agua. Otras filtraciones bajo pedido.
- Juntas: estándar Buna-N. Bajo pedido Viton.
- Temperatura de trabajo: de -30°C a +110°C.
- Presión de trabajo: 12bar. Presión de rotura: 25bar. Presión de colapso cartucho: 5 bar
- Test efectuado según normativa: ISO 2941 / ISO 3724 / ISO 3968.

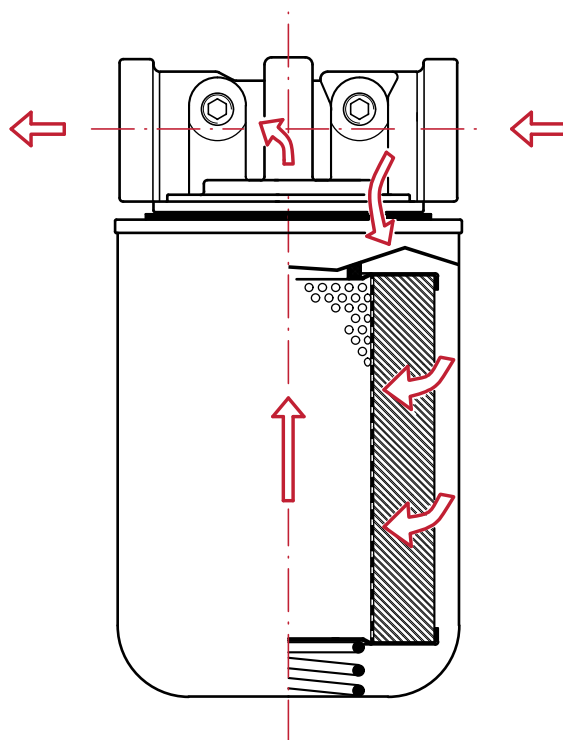

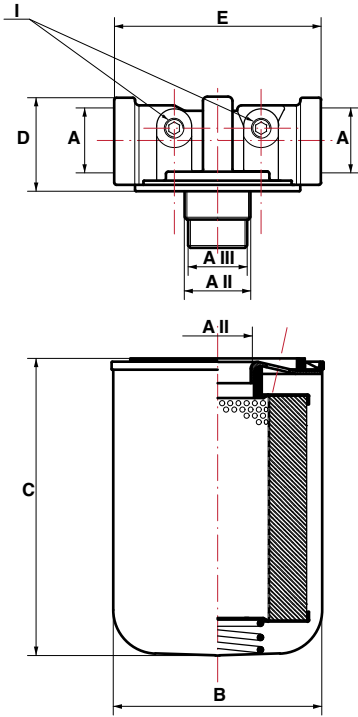

## HL10-20

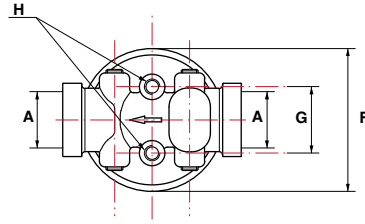

### CARTUCCIA SINGOLA SINGLE CARTRIDGE

Mod.	A	A II	A III	B	C	D	E	F	G	H	I
HL101	3/4" bspp	3/4" bspp	-	95	147	43	95	75,5	38	M8	1/8" bspp
HL102	3/4" bspp	3/4" bspp	-	95	192	43	95	75,5	38	M8	1/8" bspp
HL203	1"1/4 bspp	1"1/4 bspp	1"1/2-16 UNF	128	182	65	133	134	55	M8	1/8" bspp
HL204	1"1/4 bspp	1"1/4 bspp	1"1/2-16 UNF	128	228	65	133	134	55	M8	1/8" bspp

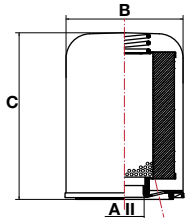

## HL30

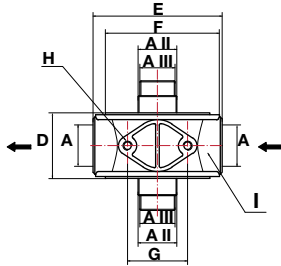

### CARTUCCIA DOPPIA CONTRAPPOSTA OPPOSED DOUBLE CARTRIDGE

Mod.	A	A II	A III	B	C	D	E	F	G	H	I
HL303	1"1/2 bspp	1"1/4 bspp	1"1/2-16 UNF	128	182	71	140	113	65	M10	1/8" bspp
HL304	1"1/2 bspp	1"1/4 bspp	1"1/2-16 UNF	128	228	71	140	113	65	M10	1/8" bspp

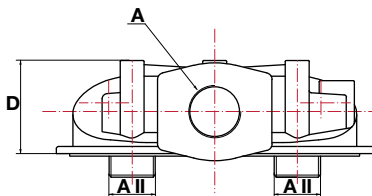
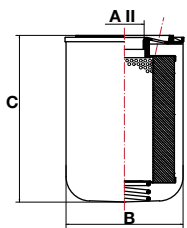

## HL40

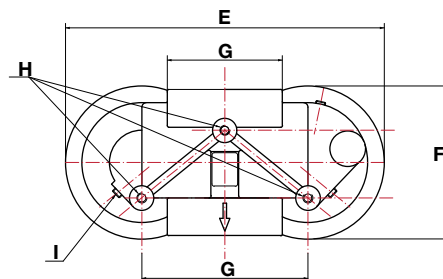

### CARTUCCIA DOPPIA PARALLELA PARALLEL DOUBLE CARTRIDGE

Mod.	A	A II	B	C	D	E	F	G	H	I
HL403	1"1/2 bspp	1"1/4 bspp	128	182	82	287	138	105	M10	1/8" bspp
HL404	1"1/2 bspp	1"1/4 bspp	128	228	82	287	138	105	M10	1/8" bspp

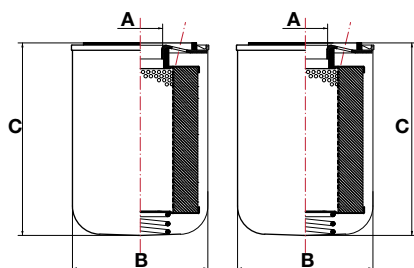

# COME ORDINARE UN FILTRO COMPLETO:

HOW TO ORDER A COMPLETE FILTER:

HL	10	1	M 10	2	
Filtro Completo Complete Filter	Tipo testa Head Type	Dimensioni cartuccia Cartridge dimensions	Elemento filtrante Filter element	Tipo by-pass By-pass type	Tipo di indicatore Indicator type
	10	1	A03	1	
	20	2	A05	2	M
	30	3	A10	3	V
	40	4	A25		I
			M10		L
			M25		P
			M60		R
			MCV		Q
			WABS		S

# COME ORDINARE UN COMPONENTE:

HOW TO ORDER A COMPONENT:

⇒ **TESTA:**  
HEAD:

**THL** . **10** **ST** **2**

**Testa Filtro**  
Filter Head

**Tipo testa**  
Head Type

**Tipo by-pass**  
By-pass type

⇒ **CARTUCCIA:**  
CARTRIDGE:

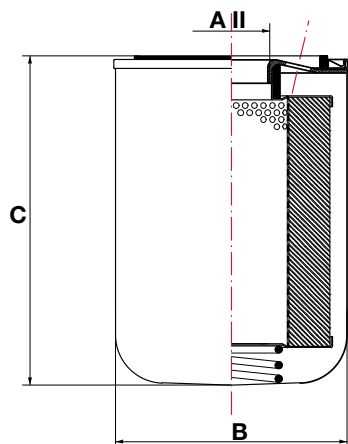

**FHL** . **1** **M 10**

**Cartuccia avvitabile**  
Spin-on Filter

**Dimensioni cartuccia**  
Cartridge dimensions

**Elemento filtrante**  
Filter element

Mod.	Dimensioni mm - Dimensions mm		
	A II	B	C
FHL.1	3/4" bspp	95	147
FHL.2	3/4" bspp	95	192
FHL.3	1"1/4 bspp	128	182
FHL.4	1"1/4 bspp	128	228



**Portate HL  
in aspirazione\*\***

Portate in l/min. rilevate con  
Dp=0.05 - 0.10 bar

**HL suction  
flow rates\*\***

Flow rate in l/min. measured with  
Dp=0.05 - 0.10 bar

**Filtedurchfluß (-saug)  
HL\*\***

Filterdurchfluß in l/min. gemessen  
bei Dp=0.05 - 0.10 bar

**Débits HL  
à l'aspiration\*\***

Débits en l/min. mesurés avec  
Dp=0.05 - 0.10 bar

**Caudales HP  
aspiración\*\***

Débits en l/min. mesurés avec  
Dp=0.05 - 0.10 bar

ELEMENTO FILTRANTE FILTERING ELEMENTS	MICROFIBRA / FIBERGLASS				CARTA / PAPER		TELA METALLICA WIRE MESH	
	Mod.	A03 3 MICRON ABS	A05 5 MICRON ABS	A10 10 MICRON ABS	A25 25 MICRON ABS	M10 10 MICRON NOM	M25 25 MICRON NOM	M60 60 MICRON NOM
HL101	7	9	13	15	16	20	30	30
HL102	8	11	15	20	22	30	35	35
HL203	18	32	40	50	53	60	95	95
HL204	27	40	54	65	70	78	100	100
HL303	48	70	95	110	115	130	150	150
HL304	55	79	102	128	130	145	150	150
HL403	48	70	95	110	115	130	150	150
HL404	55	79	102	128	130	145	150	150

\*\* Portate rilevate con olio avente viscosità cinematica di 30 cSt e densità 0.86 kg/dm<sup>3</sup>

\*\* Flow rates measured with oil of 30 cSt kinematic viscosity and 0.86 kg/dm<sup>3</sup>

**Portate HL  
al ritorno\*\***

Portate in l/min. rilevate con  
Dp=0.4 - 0.5 bar

**HL Flow rates  
on return line\*\***

Flow rate in l/min. measured with  
Dp=0.4 - 0.5 bar

**Filtedurchfluß HL  
im Rücklauf\*\***

Filterdurchfluß in l/min. gemessen  
bei Dp=0.4 - 0.5 bar

**Débits HL  
au retour\*\***

Débits en l/min. mesurés avec  
Dp=0.4 - 0.5 bar

**Caudales HP  
retorno\*\***

Débits en l/min. mesurés avec  
Dp=0.4 - 0.5 bar

ELEMENTO FILTRANTE FILTERING ELEMENTS	MICROFIBRA / FIBERGLASS				CARTA / PAPER		TELA METALLICA WIRE MESH	
	Mod.	A03 3 MICRON ABS	A05 5 MICRON ABS	A10 10 MICRON ABS	A25 25 MICRON ABS	M10 10 MICRON NOM	M25 25 MICRON NOM	M60 60 MICRON NOM
HL101	30	35	48	65	68	73	80	80
HL102	34	41	55	69	74	80	90	90
HL203	87	102	118	125	130	170	190	190
HL204	92	110	125	135	150	188	205	205
HL303	190	242	270	280	290	325	360	360
HL304	205	255	283	292	305	340	375	375
HL403	190	242	270	280	290	325	360	360
HL404	205	255	283	292	305	340	375	375

\*\* Portate rilevate con olio avente viscosità cinematica di 30 cSt e densità 0.86 kg/dm<sup>3</sup>

\*\* Flow rates measured with oil of 30 cSt kinematic viscosity and 0.86 kg/dm<sup>3</sup>

- Compatibilità con fluidi: oli minerali (HH-HL-HM-HR-HV-HG) e fluidi sintetici (HS-HFDR-HFDU-HFDS).
- Fluid compatibility: mineral oil (HH-HL-HM-HR-HV-HG) and synthetic fluids (HS-HFDR-HFDU-HFDS).

# INDICATORI INTASAMENTO (ASPIRAZIONE)

CLOGGING INDICATORS (SUCTION) - VERSCHMUTZUNGSANZEIGEN (SAUG) - INDICATEURS DE COLMAGE (ASPIRATION) - INDICADORES DE SUCIEDAD (ASPIRACION)

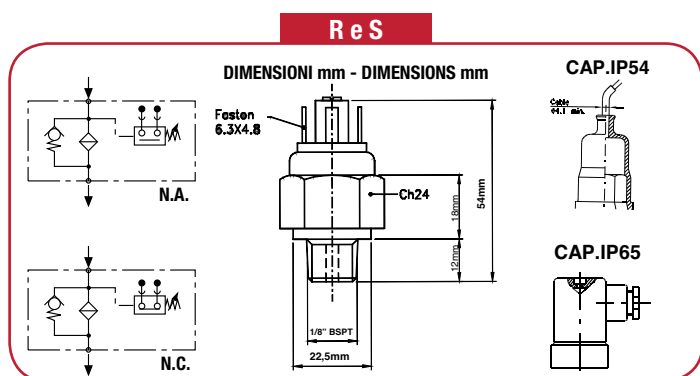
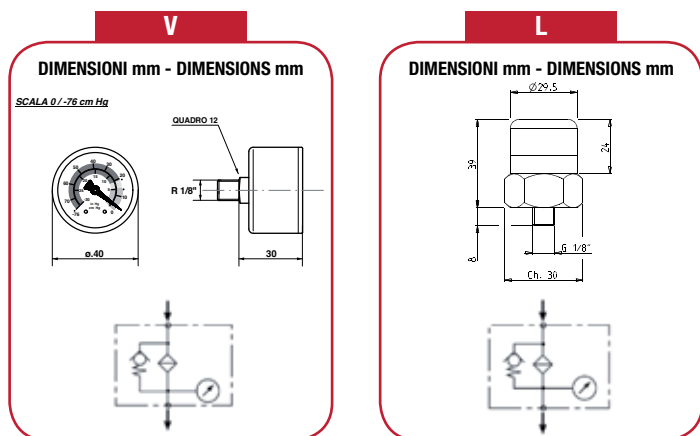

SERIE SERIES	TARATURA SETTING	TIPO - TYPE
<b>V</b>	0÷ -1 bar	Vuotometro Vacuum gauge Vakuummeter Vacuomètre Vuotometro
<b>L</b>	-0,15 bar	Vacuostato visivo Visual vacuum indicator Visuelle Vakuumschalter Vacuostat visuel Vacuostato visual
<b>R</b>	-0,2 bar	Vuotostato N.A. (Max 240V/0,4A) / (48V/0,5A) Vacuum switch N.O. (Max 240V/0,4A) / (48V/0,5A) Vakuumschalter N.O. (Max 240V/0,4A) / (48V/0,5A) Vacuostat N.O. (Max 240V/0,4A) / (48V/0,5A) Vacuostato N.A. (Max 240V/0,4A) / (48V/0,5A)
<b>S</b>	-0,2 bar	Vuotostato N.C. (Max 240V/0,4A) / (48V/0,5A) Vacuum switch N.C. (Max 240V/0,4A) / (48V/0,5A) Vakuumschalter N.C. (Max 240V/0,4A) / (48V/0,5A) Vacuostat N.F. (Max 240V/0,4A) / (48V/0,5A) Vacuostato N.A. (Max 240V/0,4A) / (48V/0,5A)

# INDICATORI INTASAMENTO (RITORNO)

CLOGGING INDICATORS (RETURN) - VERSCHMUTZUNGSANZEIGEN (RÜCKLAUF) - INDICATEURS DE COLMAGE (RETOUR) - INDICADORES DE SUCIEDAD (RETORNO)

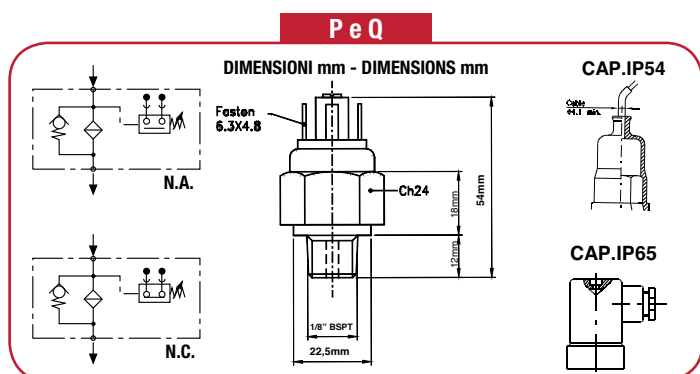
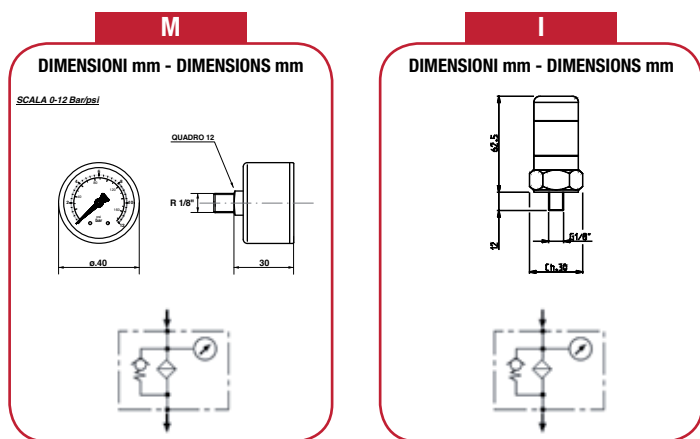

SERIE SERIES	TARATURA SETTING	TIPO - TYPE
<b>M</b>	0÷ 12 bar	Manometro Pressure gauge Manometer Manomètre Manometro
<b>I</b>	1,5 bar	Pressostato visivo Visual pressure indicator Optisch Differenzdruckanzeige Pressostat visuel Presostato visual
<b>P</b>	1,5 bar	Pressostato N.A. (Max 240V/0,4A) / (48V/0,5A) Pressure switch N.O. (Max 240V/0,4A) / (48V/0,5A) Druckschalter N.O. (Max 240V/0,4A) / (48V/0,5A) Pressostat N.O. (Max 240V/0,4A) / (48V/0,5A) Presostato N.A. (Max 240V/0,4A) / (48V/0,5A)
<b>Q</b>	1,5 bar	Pressostato N.C. (Max 240V/0,4A) / (48V/0,5A) Pressure switch N.C. (Max 240V/0,4A) / (48V/0,5A) Druckschalter N.C. (Max 240V/0,4A) / (48V/0,5A) Pressostat N.F. (Max 240V/0,4A) / (48V/0,5A) Presostato N.C. (Max 240V/0,4A) / (48V/0,5A)

# Filtri avvitabili per piccole portate

Spin-on filters for small flow rates - Spin-on Filter für kleine Durchflussmengen

Filtres à visser pour petits débits - Filtros roscados para pequeños caudales

**IT** Filtri avvitabili per piccole portate ideali per montaggio diretto ai componenti (blocchi idraulici o centraline)

**EN** Spin-on filters for small flow rates, ideal for direct mounting on components (hydraulic blocks or power packs)

**D** Spin-on Filter für kleine Durchflussmengen, ideal für direkte Montage auf Komponenten (hydraulische Block oder Aggregate).

**FR** Filtres à visser pour petits débits, idéaux pour montage direct aux composants (blocs hydrauliques ou centrales)

**ES** Filtros roscados para pequeños caudales, ideales para el montaje directo a los componentes (bloques hidráulicos o centrales)

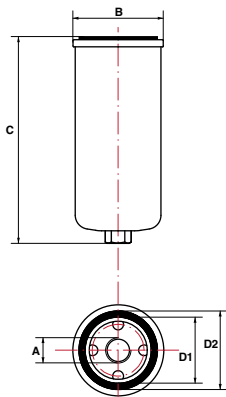

## F02.01385

- Elemento filtrante: carta 10-15 Micron nom.  
Filter element: paper 10-15 Micron nom.
- Valvola by-pass: ap. 1 bar  
By-pass valve: op. 1 bar
- Pressione esercizio: 10 bar  
Working pressure: 10 bar

DIMENSIONI mm - DIMENSIONS mm						
Mod.	A	B	C	D1	D2	PORTATA - FLOW l/m**
<b>F02.01385</b>	M14x1,5	50	118	37	44	16

\*\* Portate rilevate con olio avente viscosità cinematica 30 cst, densità 0,86 kg/dm<sup>3</sup> e Δp=0,03 bar.

\*\* Flow rates measured with oil of 30 cst kinematic viscosity, 0,86 kg/dm<sup>3</sup> density and Δp=0,03 bar.

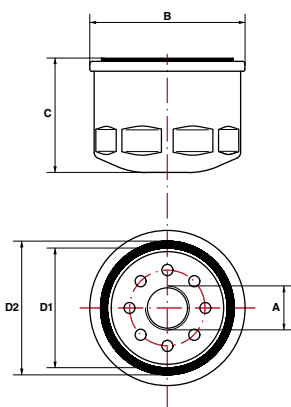

## F05.01437

- Elemento filtrante: carta 10-15 Micron nom.  
Filter element: paper 10-15 Micron nom.
- Valvola by-pass: ap. 0,8 bar  
By-pass valve: op. 0,8 bar
- Pressione esercizio: 10 bar  
Working pressure: 10 bar

DIMENSIONI mm - DIMENSIONS mm						
Mod.	A	B	C	D1	D2	PORTATA - FLOW l/m**
<b>F05.01437</b>	M20x1,5	79	59	62	72	20

\*\* Portate rilevate con olio avente viscosità cinematica 30 cst, densità 0,86 kg/dm<sup>3</sup> e Δp=0,03 bar.

\*\* Flow rates measured with oil of 30 cst kinematic viscosity, 0,86 kg/dm<sup>3</sup> density and Δp=0,03 bar.

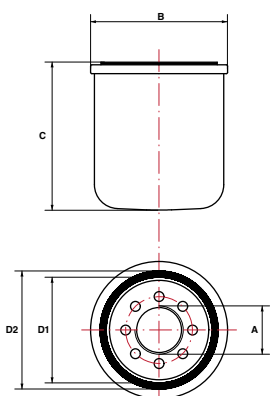

## F09.05143

- Elemento filtrante: carta 10-15 Micron nom.  
Filter element: paper 10-15 Micron nom.
- Valvola by-pass: ap. 1,6 bar  
By-pass valve: op. 1,6 bar
- Pressione esercizio: 10 bar  
Working pressure: 10 bar

- Ideale per montaggio con testa alluminio  
**THL.10**  
Ideal for mounting with aluminium head  
**THL.10**

DIMENSIONI mm - DIMENSIONS mm						
Mod.	A	B	C	D1	D2	PORTATA - FLOW l/m**
<b>F09.05143</b>	3/4" bspp	79	81	62	72	28

\*\* Portate rilevate con olio avente viscosità cinematica 30 cst, densità 0,86 kg/dm<sup>3</sup> e Δp=0,03 bar.

\*\* Flow rates measured with oil of 30 cst kinematic viscosity, 0,86 kg/dm<sup>3</sup> density and Δp=0,03 bar.

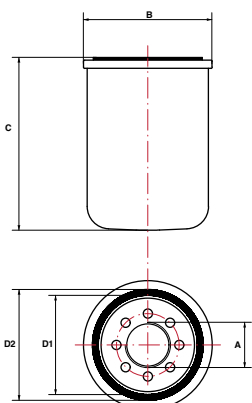

## HAO.07027

- Elemento filtrante: carta 10-15 Micron nom.  
Filter element: paper 10-15 Micron nom.
- Valvola by-pass: no  
By-pass valve: no
- Pressione esercizio: 25 bar  
Working pressure: 25 bar

DIMENSIONI mm - DIMENSIONS mm						
Mod.	A	B	C	D1	D2	PORTATA - FLOW l/m**
<b>HAO.07027</b>	3/4"-16 UNF	79	100	62	72	32

\*\* Portate rilevate con olio avente viscosità cinematica 30 cst, densità 0,86 kg/dm<sup>3</sup> e Δp=0,03 bar.

\*\* Flow rates measured with oil of 30 cst kinematic viscosity, 0,86 kg/dm<sup>3</sup> density and Δp=0,03 bar.



# Filtri per montaggio al serbatoio

## SERIE SIF - FSI - HR - FAR

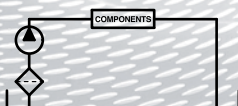

Filtri in aspirazione  
Suction filters  
Saugfilter  
Filtres d'aspiration  
Filtros en aspiracion

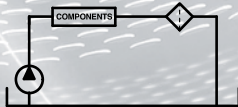

Filtri sul ritorno  
Return-line filters  
Rücklauffilter  
Filtres retour  
Filtros retorno

GB

Tank-top filters

D

Tankeinbaufilter

FR

Filtres pour montage au reservoir

ES

Filtros para montaje al deposito

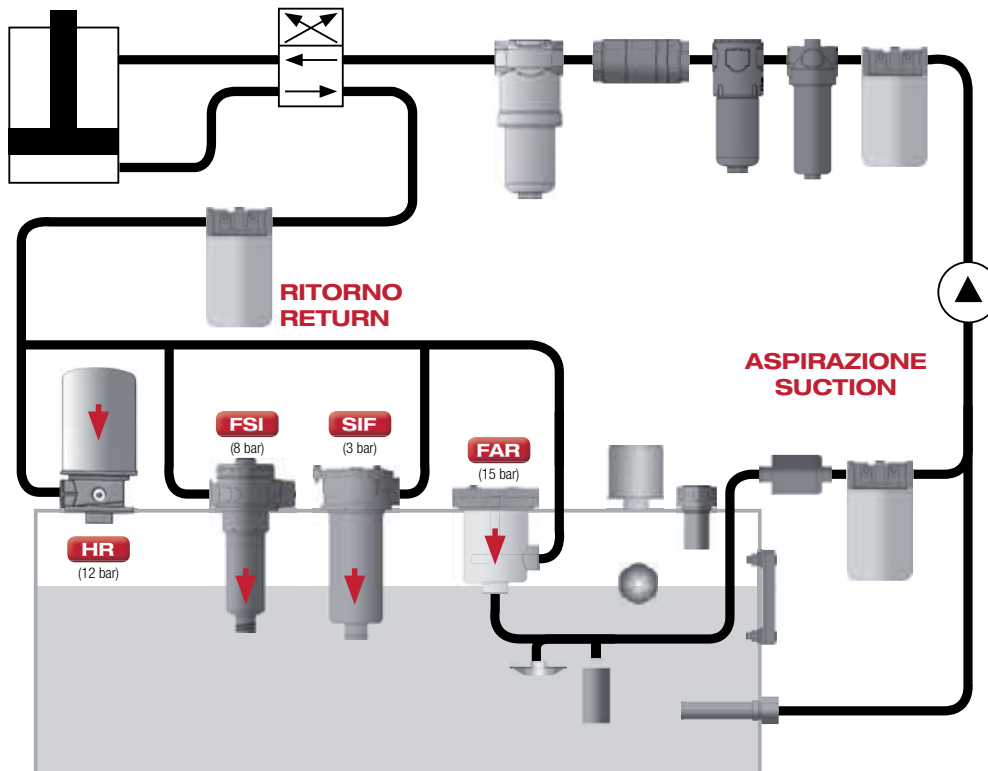

**IT** I filtri serie SIF-FSI-HR-FAR vengono utilizzati principalmente sul ritorno (scarico). Si montano direttamente sul coperchio del serbatoio idraulico, per immettervi il fluido pulito dalla contaminazione derivante dal precedente lavoro dei componenti del sistema. I filtri serie SIF-FSI vengono montati semimmersi nel serbatoio al ritorno, i filtri con cartuccia avvitabile (a perdere) serie HR vengono montati sul coperchio del serbatoio al ritorno, mentre i filtri serie FAR vengono montati semimmersi nel serbatoio, principalmente per applicazioni stazionarie, sia in aspirazione che al ritorno. Si tratta di filtri molto versatili studiati per le più svariate applicazioni: macchine utensili, agricole, movimento terra, veicoli industriali, applicazioni mobili e stazionarie in genere. Sono disponibili diversi modelli per soddisfare tutte le esigenze, dalle piccole alle grandi portate, con diversi elementi filtranti tali da garantire la massima protezione del circuito. Possiamo inoltre realizzare filtri speciali su richiesta del cliente.

**GB** SIF-FSI-HR-FAR series filters are mainly used on return line (discharge). They are directly assembled on hydraulic tank cover (tank-top), to clean fluid by contamination deriving from previous work of system components. SIF-FSI series filters are mounted semi-immersed in tank on return line, spin-on filters (disposable) series HR are mounted on tank cover, while filters FAR series are mounted semi-immersed in tank, mainly for stationary applications, on both suction and return line. It is a very versatile series of filters, designed for various applications: tools, agricultural and earthmoving machines, industrial vehicles, mobile and stationary applications in general. There are several models to meet all needs, from small to large flows, with different filter elements in order to ensure maximum protection to the circuit. We can also produce special filters upon customer request.

**D** Die Filter Serie SIF-FSI-HR-FAR sind hauptsächlich auf Rücklauf (Ablauf) verwendet. Sie werden direkt auf hydraulischen Tankdeckel (Tank-Top) montiert, um die Flüssigkeit von Verschmutzung aus früheren Arbeiten der Systemkomponente zu reinigen. SIF-FSI-Filter werden in die Rücklaufleitung integriert und zu einem Teil im Tank versenkt. Die Einweg-Aufschraubfilter vom Typ HR werden direkt am Tankdeckel verschraubt, während die Filter der FAR-Serie ebenfalls zum einem Teil im Tank versenkt werden und – in Saug- und Rücklaufleitungen montiert – besonders für stationäre Anwendungen geeignet sind. Diese Filterserien finden in verschiedensten Bereichen Verwendung: Werkzeuge, Landwirtschaftliche Fahrzeuge und Maschinen, Baufahrzeuge und -Maschinen, Industriefahrzeuge, allgemeine mobile- und stationäre Anwendungen. Wir bieten Ihnen Modelle in großer Auswahl (kleine bis große Durchflussmengen, verschiedene Filtereinsätze), um auch speziellsten Bedürfnissen gerecht zu werden und Ihre Hydraulikschaltungen jederzeit bestmöglich zu schützen. Und: Wir produzieren auch speziell nach Kundenwunsch.

**FR** Les filtres série SIF-FSI-HR-FAR sont principalement utilisés pour le retour (décharge). Ils se montent directement sur le couvercle du réservoir hydraulique, pour introduire le fluide nettoyé de la contamination résultant de travaux antérieurs des composants du système. Les filtres série SIF-FSI sont montés semi-immergés dans le réservoir sur le retour, les filtres à visser (jetables) série HR sont montés directement sur le couvercle du réservoir pour le retour, tandis que les filtres série FAR sont montés semi-immergés dans le réservoir, principalement pour des applications stationnaires, utilisés tant sur les lignes d'aspiration que de retour. C'est une série très polyvalente de filtres, conçus pour diverses applications: machines outils, agricoles et de chantiers, véhicules industriels, applications mobiles et stationnaires en général. Il existe plusieurs modèles pour répondre à tous les besoins, pour débits petits ou grands, avec différents éléments filtrants, afin d'assurer une protection maximale du circuit. Nous pouvons aussi produire filtres spéciaux sur demande du client.

**ES** Los filtros serie SIF-FSI-HR-FAR se utilizan principalmente en retorno (descarga). Se montan directamente sobre la tapa del depósito hidráulico, para devolver el fluido limpio de la contaminación derivada del trabajo de los componentes del sistema. Los filtros serie SIF-FSI se montan semi-inmersos en el depósito en retorno; los filtros con cartucho roscado (desechables) serie HR se montan en la tapa del depósito en retorno, mientras que los filtros serie FAR se montan semi-inmersos en el depósito, principalmente en aplicaciones estacionarias, sea en aspiración ó en retorno. Se trata de filtros muy versátiles estudiados para las mas variadas aplicaciones: máquina herramienta, agrícola, obra pública, vehículos industriales, aplicaciones móviles y estacionarias en general. Están disponibles diversos modelos para satisfacer todas las exigencias, desde pequeños a grandes caudales, con distintos elementos filtrantes tales que garantizan la máxima protección del circuito. Podemos además producir filtros especiales bajo pedido del cliente.



# SERIE SIF

## IT Filtri sul ritorno (scarico) per montaggio semimmersi nel serbatoio.

### CARATTERISTICHE TECNICHE:

- Testata + coperchio: fusione di alluminio.
- Vasca filtro: nylon (plastica) per serie 10A+B/15B+C/20C. Acciaio zincato per serie 15L/20L+D/25D+E/30E+F+G/35H.
- Valvola by-pass: Apertura standard 1,7 bar.
- Attacchi disponibili standard: 1/2"-3/4"-1"-1 1/4"-1 1/2"-2" bsp. Filettature speciali su richiesta.
- Elementi filtranti disponibili standard: 10-25 Micron abs. Microfibra / 10-25 Micron nom. carta (norm. o rinf.) / 60-90 Micron nom. tela met. Altre filtrazioni su richiesta.
- Guarnizioni: standard Buna-N. Su richiesta Viton.
- Temperatura esercizio: da -25°C a +110°C.
- Pressione di esercizio: 3 bar. Pressione di scoppio: 10 bar.
- Test eseguiti secondo normative: ISO 2941 / ISO 3724 / ISO 3968.

## EN Return-line filters (discharge) for mounting semi-immersed in tank (tank-top filters).

### TECHNICAL FEATURES:

- Head + cover: aluminium die-casting.
- Filter bowl: nylon (plastic) for series 10A+B/15B+C/20C. Galvanized steel for series 15L/20L+D/25D+E/30E+F+G/35H.
- By-pass valve: Standard opening 1,7 bar.
- Standard available threads: 1/2"-3/4"-1"-1 1/4"-1 1/2"-2" bsp. Other threads upon request.
- Standard available filter elements: 10-25 Micron abs. Microfiber / 10-25 Micron nom. paper (norm. or rinf.) / 60-90 Micron nom. wire mesh. Other filter elements upon request.
- Seals: Buna-N standard. Viton upon request.
- Operating temperature: -25°C +110°C.
- Operating pressure: 3 bar. Burst pressure: 10 bar.
- Tested according standards: ISO 2941 / ISO 3724 / ISO 3968.

## D Rücklauf-Tankeinbaufilter (Ablauf Tank-top Filter)

### TECHNISCHE DATEN:

- Filterkopf + Deckel: Aluminium-Druckguss.
- Filtergehäuse: Nylon (Kunststoff) für Serie 10A+B/15B+C/20C. Verzinktem Stahl für Serie 15L/20L+D/25D+E/30E+F+G/35H.
- By-pass Ventil: Standardöffnung 1,7 bar.
- Standard verfügbaren Anschlüssen: 1/2"-3/4"-1"-1 1/4"-1 1/2"-2" bsp. Weitere Gewinde auf Anfrage erhältlich.
- Standard verfügbaren Filterelemente: 10-25 Mik. abs. Microfaser / 10-25 Mik. nom. Papier (norm. Und vers.) / 60-90 Mik. nom. Drahtgewebe. Weitere Materialien auf Anfrage erhältlich.
- Dichtungen: Buna-N Standard. Viton auf Wunsch.
- Betriebstemperatur: von -25°C bis +110°C.
- Betriebsdruck: 3 bar. Berstdruck: 10 bar.
- Test nach Normen: ISO 2941 / ISO 3724 / ISO 3968.

## FR Filtres de retour (décharge) pour montage semi-immergés dans le réservoir.

### CARACTERISTIQUES TECHNIQUES:

- Tête + couvercle: fusion d'aluminium.
- Bol du filtre: nylon (plastique) pour série 10A+B/15B+C/20C. Acier galvanisé pour série 15L/20L+D/25D+E/30E+F+G/35H.
- Clapet by-pass: Ouverture standard 1,7 bar.
- Connexions standard disponibles: 1/2"-3/4"-1"-1 1/4"-1 1/2"-2" bsp. Filetages spéciaux sur demande.
- Eléments filtrants standard disponibles: 10-25 Micron abs. en microfibre / 10-25 Micron nom. papier (norm. ou renf.) / 60-90 Micron nom. Toile met. Autres filtrations sur demande.
- Joints: Buna-N standard. Viton sur demande.
- Temperature de travail: de -25°C à +110°C.
- Pression de service: 3 bar. Pression d'éclatement: 10 bar.
- Test selon standards: ISO 2941 / ISO 3724 / ISO 3968.

## ES Filtros en retorno (descarga) para montaje semi-inmerso en deposito.

### CARACTERÍSTICAS TÉCNICAS:

- Cabeza + cuerpo: aluminio
- Contenedor filtro: nylon (plástico) para las series 10A+B/15B+C/20C. Acero cincado para las series 15L/20L+D/25D+E/30E+F+G/35H.
- Válvula de by-pass Apertura standar 1,7 bar.
- Conexiones disponibles estándar: 1/2"-3/4"-1"-1 1/4"-1 1/2"-2" bsp. Rosca especial bajo pedido.
- Elemento filtrante disponible estándar: 10-25 micras abs. en Microfibra / 10-25 micras nom. en Papel (norm. o renf.) / 60-90 micras nom. en Tela. Otras filtraciones bajo pedido.
- Juntas: standar Buna-N. Bajo pedido Viton.
- Temperatura de trabajo: de -25°C a +110°C.
- Presión de trabajo: 3 bar. Presión de rotura: 10 bar
- Prueba realizada según normativa: ISO 2941 / ISO 3724 / ISO 3968.

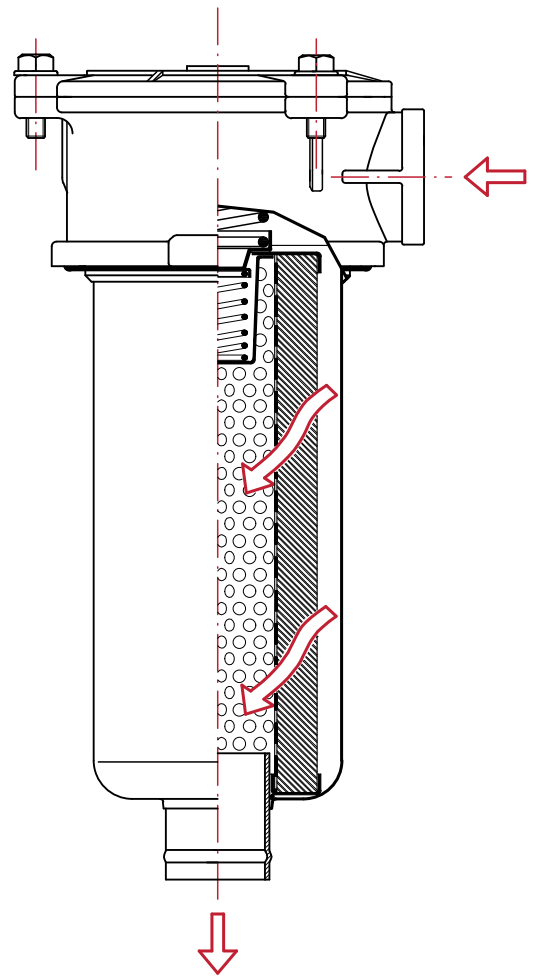



# SIF.10A/B - 15B/C/L - 20C/L

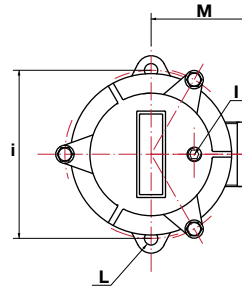
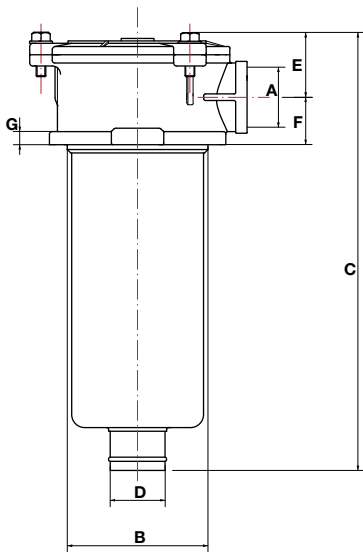

## 2 FORI FISSAGGIO - 2 FIXING HOLES

Mod.	DIMENSIONI mm - DIMENSIONS mm										
	A	B	C	D	E	F	G	H	I	L	M
SIF.10A	1/2"	66	140	24	31	22	9	90	1/8" bspp	8	50
SIF.10B	bspp		173	28	41	29	10	115		9	67
SIF.15B	3/4" bspp	220									
SIF.15C		285	40								
SIF.15L		218	28								
SIF.20C	1" bspp	285	40								
SIF.20L											

# SIF.20D - 25D

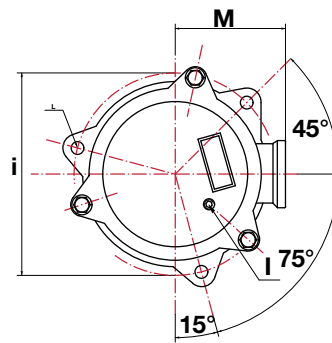
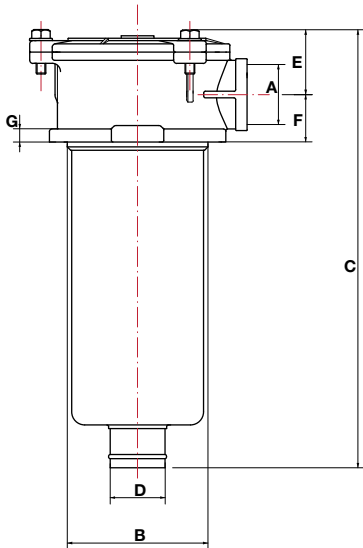

## 3 FORI FISSAGGIO - 3 FIXING HOLES

Mod.	DIMENSIONI mm - DIMENSIONS mm										
	A	B	C	D	E	F	G	H	I	L	M
SIF.20D	1" bspp	129	314	40	50	36	10	175	1/8" bspp	11	95
SIF.25D	1" 1/4 bspp										

# SIF.25E - 30E/F/G - 35H

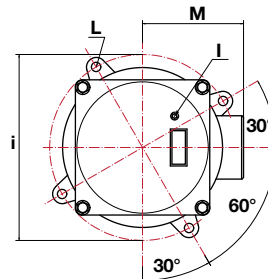
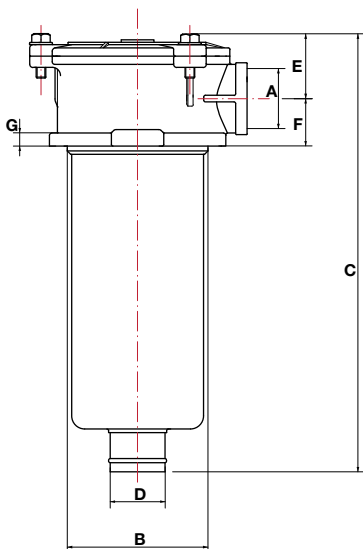

## 4 FORI FISSAGGIO - 4 FIXING HOLES

Mod.	DIMENSIONI mm - DIMENSIONS mm										
	A	B	C	D	E	F	G	H	I	L	M
SIF.25E	1" 1/4 bspp	173	270	50	57	38	11	220	1/8" bspp	11	120
SIF.30E	1" 1/2 bspp		330								
SIF.30F				330							
SIF.30G			377								
SIF.35H	2" bspp										

# COME ORDINARE UN FILTRO COMPLETO:

HOW TO ORDER A COMPLETE FILTER:

<b>SIF</b>	.	<b>20</b>	<b>C</b>	<b>30</b>																																							
<b>Filtro completo</b> Complete filter	<b>Filetto</b> Thread	<b>Dimensioni</b> Dimensions	<b>Elemento filtrante</b> Filter Element	<b>Tipo di indicatore</b> Indicator type																																							
	<table border="1"> <tr><td><b>10</b></td><td>1/2" bspp</td></tr> <tr><td><b>15</b></td><td>3/4" bspp</td></tr> <tr><td><b>20</b></td><td>1" bspp</td></tr> <tr><td><b>25</b></td><td>1" 1/4 bspp</td></tr> <tr><td><b>30</b></td><td>1" 1/2 bspp</td></tr> <tr><td><b>35</b></td><td>2" bspp</td></tr> </table>	<b>10</b>	1/2" bspp	<b>15</b>	3/4" bspp	<b>20</b>	1" bspp	<b>25</b>	1" 1/4 bspp	<b>30</b>	1" 1/2 bspp	<b>35</b>	2" bspp	Vedi tabella pag. 35 See table page 35	<table border="1"> <tr><td><b>10A</b></td><td>MICROFIBRA 10µm abs 10µm MICROFIBERGLASS abs</td></tr> <tr><td><b>25A</b></td><td>MICROFIBRA 25µm abs 25µm MICROFIBERGLASS abs</td></tr> <tr><td><b>M10C</b></td><td>solo CARTA 10µm nom 10µm just PAPER nom</td></tr> <tr><td><b>M30C</b></td><td>solo CARTA 25µm nom 25µm just PAPER nom</td></tr> <tr><td><b>M10</b></td><td>CARTA RINFORZATA 10µm nom 10µm REINFORCED PAPER nom</td></tr> <tr><td><b>M30</b></td><td>CARTA RINFORZATA 25µm nom 25µm REINFORCED PAPER nom</td></tr> <tr><td><b>M60</b></td><td>TELA METALLICA 60µm nom 60µm METAL MESH nom</td></tr> <tr><td><b>M90</b></td><td>TELA METALLICA 90µm nom 90µm METAL MESH nom</td></tr> </table>	<b>10A</b>	MICROFIBRA 10µm abs 10µm MICROFIBERGLASS abs	<b>25A</b>	MICROFIBRA 25µm abs 25µm MICROFIBERGLASS abs	<b>M10C</b>	solo CARTA 10µm nom 10µm just PAPER nom	<b>M30C</b>	solo CARTA 25µm nom 25µm just PAPER nom	<b>M10</b>	CARTA RINFORZATA 10µm nom 10µm REINFORCED PAPER nom	<b>M30</b>	CARTA RINFORZATA 25µm nom 25µm REINFORCED PAPER nom	<b>M60</b>	TELA METALLICA 60µm nom 60µm METAL MESH nom	<b>M90</b>	TELA METALLICA 90µm nom 90µm METAL MESH nom	<table border="1"> <tr><td></td><td>senza-solo predisposizione / without-just predisposition</td></tr> <tr><td><b>N</b></td><td>manometro att. radiale manometer with radial conn.</td></tr> <tr><td><b>I</b></td><td>pressostato visivo visual pressure indicator</td></tr> <tr><td><b>P</b></td><td>pressostato n.a. / pressure switch n.o. for return line</td></tr> <tr><td><b>Q</b></td><td>pressostato n.c. / pressure switch n.c. for return line</td></tr> </table>			senza-solo predisposizione / without-just predisposition	<b>N</b>	manometro att. radiale manometer with radial conn.	<b>I</b>	pressostato visivo visual pressure indicator	<b>P</b>	pressostato n.a. / pressure switch n.o. for return line	<b>Q</b>	pressostato n.c. / pressure switch n.c. for return line
<b>10</b>	1/2" bspp																																										
<b>15</b>	3/4" bspp																																										
<b>20</b>	1" bspp																																										
<b>25</b>	1" 1/4 bspp																																										
<b>30</b>	1" 1/2 bspp																																										
<b>35</b>	2" bspp																																										
<b>10A</b>	MICROFIBRA 10µm abs 10µm MICROFIBERGLASS abs																																										
<b>25A</b>	MICROFIBRA 25µm abs 25µm MICROFIBERGLASS abs																																										
<b>M10C</b>	solo CARTA 10µm nom 10µm just PAPER nom																																										
<b>M30C</b>	solo CARTA 25µm nom 25µm just PAPER nom																																										
<b>M10</b>	CARTA RINFORZATA 10µm nom 10µm REINFORCED PAPER nom																																										
<b>M30</b>	CARTA RINFORZATA 25µm nom 25µm REINFORCED PAPER nom																																										
<b>M60</b>	TELA METALLICA 60µm nom 60µm METAL MESH nom																																										
<b>M90</b>	TELA METALLICA 90µm nom 90µm METAL MESH nom																																										
	senza-solo predisposizione / without-just predisposition																																										
<b>N</b>	manometro att. radiale manometer with radial conn.																																										
<b>I</b>	pressostato visivo visual pressure indicator																																										
<b>P</b>	pressostato n.a. / pressure switch n.o. for return line																																										
<b>Q</b>	pressostato n.c. / pressure switch n.c. for return line																																										

# COME ORDINARE LA CARTUCCIA DI RICAMBIO:

HOW TO ORDER THE REPLACEMENT ELEMENT:

	<b>FXR</b>	.	<b>A6</b>	<b>M30</b>																																																																																																																											
	<b>Cartuccia</b> Cartridge	<b>Ricambio per</b> Replacement for	<b>Elemento filtrante</b> Filter Element	<b>Kit molla + O-Ring</b> Kit spring + O-Ring																																																																																																																											
	<table border="1"> <thead> <tr> <th colspan="5">Dimensioni mm - Dimensions mm</th> </tr> <tr> <th>Mod.</th> <th>A</th> <th>B</th> <th>C</th> <th>D</th> </tr> </thead> <tbody> <tr><td><b>FXR.A3</b></td><td>26</td><td>50</td><td>70</td><td>5,5</td></tr> <tr><td><b>FXR.A5</b></td><td>29</td><td>70</td><td>81</td><td>8</td></tr> <tr><td><b>FXR.A6</b></td><td>29</td><td>70</td><td>130</td><td>8</td></tr> <tr><td><b>FXR.S6</b></td><td>42</td><td>70</td><td>210</td><td>8</td></tr> <tr><td><b>FXR.A7</b></td><td>41</td><td>95</td><td>170</td><td>8</td></tr> <tr><td><b>FXR.A8</b></td><td>41</td><td>95</td><td>202</td><td>8</td></tr> <tr><td><b>FXR.S1</b></td><td>41</td><td>95</td><td>250</td><td>8</td></tr> <tr><td><b>FXR.S3</b></td><td>41</td><td>95</td><td>280</td><td>8</td></tr> <tr><td><b>FXR.A9</b></td><td>65</td><td>130</td><td>136</td><td>8</td></tr> <tr><td><b>FXR.A0</b></td><td>52</td><td>130</td><td>136</td><td>8</td></tr> <tr><td><b>FXR.B1</b></td><td>52</td><td>130</td><td>202</td><td>8</td></tr> <tr><td><b>FXR.B2</b></td><td>65</td><td>130</td><td>202</td><td>8</td></tr> <tr><td><b>FXR.B3</b></td><td>65</td><td>130</td><td>202</td><td>8</td></tr> <tr><td><b>FXR.B4</b></td><td>65</td><td>130</td><td>250</td><td>8</td></tr> <tr><td><b>FXR.S2</b></td><td>65</td><td>130</td><td>267</td><td>8</td></tr> <tr><td><b>FXR.B5</b></td><td>65</td><td>130</td><td>403</td><td>8</td></tr> </tbody> </table>		Dimensioni mm - Dimensions mm					Mod.	A	B	C	D	<b>FXR.A3</b>	26	50	70	5,5	<b>FXR.A5</b>	29	70	81	8	<b>FXR.A6</b>	29	70	130	8	<b>FXR.S6</b>	42	70	210	8	<b>FXR.A7</b>	41	95	170	8	<b>FXR.A8</b>	41	95	202	8	<b>FXR.S1</b>	41	95	250	8	<b>FXR.S3</b>	41	95	280	8	<b>FXR.A9</b>	65	130	136	8	<b>FXR.A0</b>	52	130	136	8	<b>FXR.B1</b>	52	130	202	8	<b>FXR.B2</b>	65	130	202	8	<b>FXR.B3</b>	65	130	202	8	<b>FXR.B4</b>	65	130	250	8	<b>FXR.S2</b>	65	130	267	8	<b>FXR.B5</b>	65	130	403	8	<table border="1"> <tr><td><b>SIF.10A</b></td><td>FXR.A3M</td></tr> <tr><td><b>SIF.10B</b></td><td>FXR.A5M</td></tr> <tr><td><b>SIF.15B</b></td><td></td></tr> <tr><td><b>SIF.15C</b></td><td>FXR.A6M</td></tr> <tr><td><b>SIF.15L</b></td><td>FXR.S6M</td></tr> <tr><td><b>SIF.20C</b></td><td>FXR.A6M</td></tr> <tr><td><b>SIF.20L</b></td><td>FXR.A8M</td></tr> <tr><td><b>SIF.20D</b></td><td>FXR.S6M</td></tr> <tr><td><b>SIF.25D</b></td><td>FXR.A8M</td></tr> <tr><td><b>SIF.25E</b></td><td></td></tr> <tr><td><b>SIF.30E</b></td><td>FXR.A0M</td></tr> <tr><td><b>SIF.30F</b></td><td>FXR.B1M</td></tr> <tr><td><b>SIF.30G</b></td><td>FXR.B2M</td></tr> <tr><td><b>SIF.35H</b></td><td>FXR.B3M</td></tr> </table>	<b>SIF.10A</b>	FXR.A3M	<b>SIF.10B</b>	FXR.A5M	<b>SIF.15B</b>		<b>SIF.15C</b>	FXR.A6M	<b>SIF.15L</b>	FXR.S6M	<b>SIF.20C</b>	FXR.A6M	<b>SIF.20L</b>	FXR.A8M	<b>SIF.20D</b>	FXR.S6M	<b>SIF.25D</b>	FXR.A8M	<b>SIF.25E</b>		<b>SIF.30E</b>	FXR.A0M	<b>SIF.30F</b>	FXR.B1M	<b>SIF.30G</b>	FXR.B2M	<b>SIF.35H</b>	FXR.B3M	<table border="1"> <tr><td></td><td>Solo cartuccia Just element</td></tr> <tr><td><b>K</b></td><td>Cartuccia + kit molla e o-ring Cartridge + kit spring and o-ring</td></tr> </table>			Solo cartuccia Just element	<b>K</b>	Cartuccia + kit molla e o-ring Cartridge + kit spring and o-ring
	Dimensioni mm - Dimensions mm																																																																																																																														
Mod.	A	B	C	D																																																																																																																											
<b>FXR.A3</b>	26	50	70	5,5																																																																																																																											
<b>FXR.A5</b>	29	70	81	8																																																																																																																											
<b>FXR.A6</b>	29	70	130	8																																																																																																																											
<b>FXR.S6</b>	42	70	210	8																																																																																																																											
<b>FXR.A7</b>	41	95	170	8																																																																																																																											
<b>FXR.A8</b>	41	95	202	8																																																																																																																											
<b>FXR.S1</b>	41	95	250	8																																																																																																																											
<b>FXR.S3</b>	41	95	280	8																																																																																																																											
<b>FXR.A9</b>	65	130	136	8																																																																																																																											
<b>FXR.A0</b>	52	130	136	8																																																																																																																											
<b>FXR.B1</b>	52	130	202	8																																																																																																																											
<b>FXR.B2</b>	65	130	202	8																																																																																																																											
<b>FXR.B3</b>	65	130	202	8																																																																																																																											
<b>FXR.B4</b>	65	130	250	8																																																																																																																											
<b>FXR.S2</b>	65	130	267	8																																																																																																																											
<b>FXR.B5</b>	65	130	403	8																																																																																																																											
<b>SIF.10A</b>	FXR.A3M																																																																																																																														
<b>SIF.10B</b>	FXR.A5M																																																																																																																														
<b>SIF.15B</b>																																																																																																																															
<b>SIF.15C</b>	FXR.A6M																																																																																																																														
<b>SIF.15L</b>	FXR.S6M																																																																																																																														
<b>SIF.20C</b>	FXR.A6M																																																																																																																														
<b>SIF.20L</b>	FXR.A8M																																																																																																																														
<b>SIF.20D</b>	FXR.S6M																																																																																																																														
<b>SIF.25D</b>	FXR.A8M																																																																																																																														
<b>SIF.25E</b>																																																																																																																															
<b>SIF.30E</b>	FXR.A0M																																																																																																																														
<b>SIF.30F</b>	FXR.B1M																																																																																																																														
<b>SIF.30G</b>	FXR.B2M																																																																																																																														
<b>SIF.35H</b>	FXR.B3M																																																																																																																														
	Solo cartuccia Just element																																																																																																																														
<b>K</b>	Cartuccia + kit molla e o-ring Cartridge + kit spring and o-ring																																																																																																																														

## Portate SIF al ritorno\*\*

Portate in l/min. rilevate con Dp=0.4 - 0.5 bar

## SIF Flow rates on return line\*\*

Flow rate in l/min. measured with Dp=0.4 - 0.5 bar

## Filterdurchfluß SIF im Rücklauf\*\*

Filterdurchfluß in l/min. gemessen bei Dp=0.4 - 0.5 bar

## Débits SIF au retour\*\*

Débits en l/min. mesurés avec Dp=0.4 - 0.5 bar

## Caudales SIF retorno\*\*

Débits en l/min. mesurés avec Dp=0.4 - 0.5 bar

ELEMENTO FILTRANTE FILTERING ELEMENTS	MICROFIBRA FIBERGLASS		CARTA PAPER				TELA METALLICA WIRE MESH	
	10A 10 MICRON ABS	25A 25 MICRON ABS	10C 10 MICRON NOM	30C 30 MICRON NOM	10 10 MICRON NOM	30 30 MICRON NOM	60 60 MICRON NOM	90 90 MICRON NOM
SIF.10A	15	17	20	25	20	25	30	35
SIF.10B	30	32	36	42	36	42	50	60
SIF.15B	35	40	42	48	42	48	60	70
SIF.15C	50	55	58	62	58	62	80	90
SIF.15L	60	74	74	80	74	80	110	122
SIF.20C	60	65	68	72	68	72	100	110
SIF.20D	90	95	100	105	100	105	150	160
SIF.20L	70	84	84	90	84	90	130	142
SIF.25D	110	115	120	130	120	130	180	190
SIF.25E	120	130	135	145	135	145	220	240
SIF.30E	130	140	150	160	150	160	250	270
SIF.30F	175	185	200	210	200	210	320	350
SIF.30G	180	190	205	215	205	215	330	360
SIF.35H	300	320	350	360	350	360	480	550

\*\* Portate rilevate con olio avente viscosità cinematica 30 cst e densità 0,86 kg/dm<sup>3</sup>.

\*\* Flow rates measured with oil of 30 cst kinematic viscosity and 0,86 kg/dm<sup>3</sup> density.

• Compatibilità con fluidi: oli minerali (HH-HL-HM-HR-HV-HG) e fluidi sintetici (HS-HFDR-HFDU-HFDS).

• Fluid compatibility: mineral oil (HH-HL-HM-HR-HV-HG) and synthetic fluids (HS-HFDR-HFDU-HFDS).©

## INDICATORI INTASAMENTO

CLOGGING INDICATORS - VERSCHMUTZUNGSANZEIGEN - INDICATEURS DE COLMAGE - INDICADORES DE SUCIEDAD

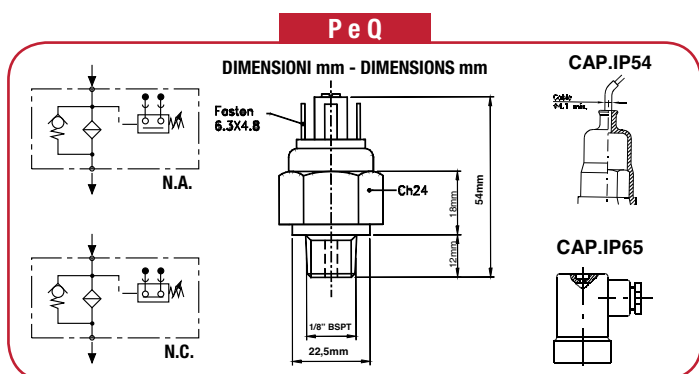
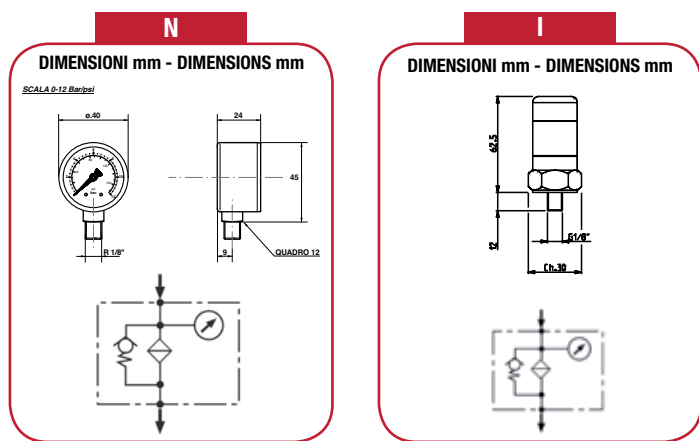

SERIE SERIES	TARATURA SETTING	TIPO - TYPE
N	0 ÷ 12 bar	Manometro (Attacco radiale) Pressure gauge (Radial connection) Manometer (Radiale Verbindung) Manomètre (Connexion radiale) Manometro (Conexión radial)
I	1,5 bar	Pressostato visivo Visual pressure indicator Optisch Differenzdruckanzeige Pressostat visuel Presostato visual
P	1,5 bar	Pressostato N.A. (Max 240V/0,4A) / (48V/0,5A) Pressure switch N.O. (Max 240V/0,4A) / (48V/0,5A) Druckschalter N.O. (Max 240V/0,4A) / (48V/0,5A) Pressostat N.O. (Max 240V/0,4A) / (48V/0,5A) Presostato N.A. (Max 240V/0,4A) / (48V/0,5A)
Q	1,5 bar	Pressostato N.C. (Max 240V/0,4A) / (48V/0,5A) Pressure switch N.C. (Max 240V/0,4A) / (48V/0,5A) Druckschalter N.C. (Max 240V/0,4A) / (48V/0,5A) Pressostat N.F. (Max 240V/0,4A) / (48V/0,5A) Presostato N.C. (Max 240V/0,4A) / (48V/0,5A)



# SERIE FSI

## IT Filtri sul ritorno (scarico) con sfiato aria e coperchio di carico per montaggio semimmersi nel serbatoio.

### CARATTERISTICHE TECNICHE:

- Testata: fusione in alluminio anodizzato.
- Vasca filtro + coperchio: nylon (plastica).
- Valvola by-pass: Apertura standard 1,7 bar.
- Attacchi disponibili standard: 1/2"-3/4"-1" bspp. Filettature speciali su richiesta.
- Elementi filtranti disponibili standard: 5-10-25 Micron abs. microfibra/10-25 Micron nom. carta (norm. o rinf.)/25-60-90 Micron nom. tela met. Altre filtrazioni su richiesta.
- Guarnizioni: standard Buna-N. Su richiesta Viton.
- Temperatura esercizio: da -25°C a +110°C.
- Pressione di esercizio: 8 bar. Pressione di scoppio: 16 bar.
- Pressione di collasso cartuccia: 10 bar.
- Test eseguiti secondo normative: ISO 2941 / ISO 3724 / ISO 3968.

## EN Return line tank-top filters (discharge) with breathing element and service cover.

### TECHNICAL FEATURES:

- Head: anodized aluminium die-casting.
- Filter bowl + cover: nylon (plastic).
- By-pass valve: Standard opening 1,7 bar.
- Standard available threads: 1/2"-3/4"-1" bspp. Other threads upon request.
- Standard available filter elements: 5-10-25 Micron abs. microfiber / 10-25 Micron nom. reinforced paper / 25-60-90 Micron nom. wire mesh. Other filter elements upon request.
- Seals: Buna-N standard. Viton upon request.
- Operating temperature: -25°C +110°C.
- Operating pressure: 8 bar. Burst pressure: 16 bar.
- Element collapse pressure: 10 bar.
- Tested according standards: ISO 2941 / ISO 3724 / ISO 3968.

## D Rücklauf-Tankeinbaufilter (Ablauf Tank-top Filter) mit Belüftungselement und Belastungsdeckel.

### TECHNISCHE DATEN:

- Filterkopf: eloxiertem Aluminium-Druckguss.
- Filtergehäuse + Deckel: Nylon (Kunststoff).
- By-pass Ventil: Standardöffnung 1,7 bar.
- Standard verfügbaren Anschlüssen: 1/2"-3/4"-1" bspp. Weitere Gewinde auf Anfrage erhältlich.
- Standard verfügbaren Filterelemente: 5-10-25 Mik. abs. Microfaser / 10-25 Mikron nom. Verstärktem Papier / 25-60-90 Mik. nom. Drahtgewebe. Weitere Materialien auf Anfrage erhältlich.
- Dichtungen: Buna-N Standard. Viton auf Wunsch.
- Betriebstemperatur: von -25°C bis +110°C.
- Betriebsdruck: 8 bar. Berstdruck: 16 bar.
- Patronekollapsdrücke: 10 bar.
- Test nach Normen: ISO 2941 / ISO 3724 / ISO 3968.

## FR Filtres de retour (décharge) semi-immergés dans le réservoir avec cartouche reniflard et couvercle de charge.

### CARACTERISTIQUES TECHNIQUES:

- Tête: fusion d'aluminium anodisé.
- Bol du filtre + couvercle: nylon (plastique).
- Clapet by-pass: Ouverture standard 1,7 bar.
- Connexions standard disponibles: 1/2"-3/4"-1" bspp. Filetages spéciaux sur demande.
- Eléments filtrants standard disponibles: 5-10-25 Micron abs. en microfibra / 10-25 Micron nom. papier renforcé / 25-60-90 Micron nom. toile met. Autres filtrations sur demande.
- Joints: Buna-N standard. Viton sur demande.
- Temperature de travaille: de -25°C à +110°C.
- Pression de service: 8 bar. Pression d'éclatement: 16 bar.
- Pression d'écrasement élément filtrant: 10 bar.
- Test selon standards: ISO 2941 / ISO 3724 / ISO 3968.

## ES Filtros en retorno (descarga) con respiradero para montaje semi-inmerso en deposito.

### CARACTERÍSTICAS TÉCNICAS:

- Cabeza: aluminio anodizado.
- Contenedor + tapa filtro: nylon (plástico).
- Válvula de by-pass: Apertura standar 1,7 bar.
- Conexiones disponibles estándar: 1/2"-3/4"-1" bspp. Rosca especial bajo pedido.
- Elemento filtrante disp. estándar: 5-10-25 micras abs. en microfibra / 10-25 micras nom. en papel (norm. o renf.) / 25-60-90 micras nom. en Tela. Otras filtraciones bajo pedido.
- Juntas: standar Buna-N. Bajo pedido Viton.
- Temperatura de trabajo: de -25°C a +110°C.
- Presión de trabajo: 8 bar. Presión de rotura: 16 bar.
- Presión de colapso del cartucho: 10 bar.
- Prueba realizada según normativa: ISO 2941 / ISO 3724 / ISO 3968.

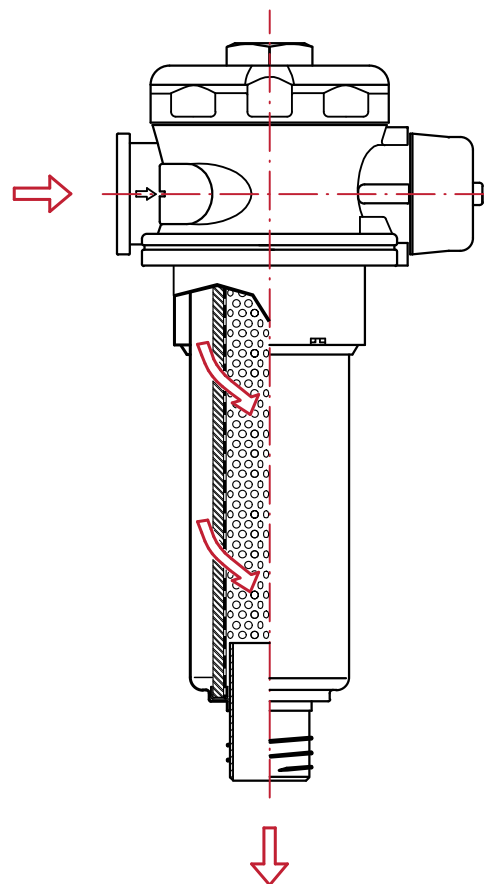

# FSI1

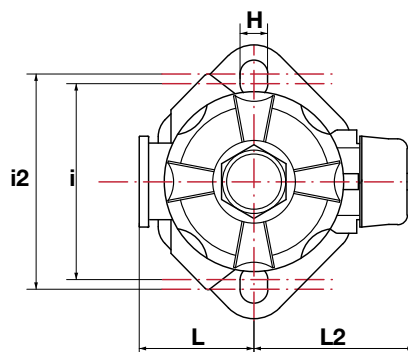
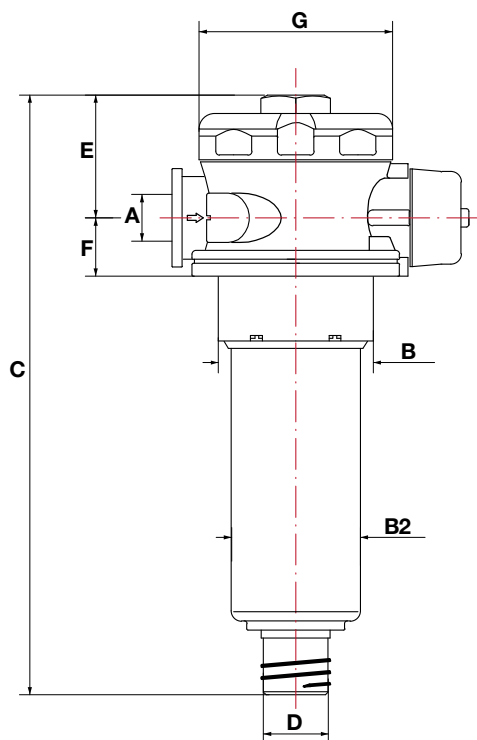

DIMENSIONI mm - DIMENSIONS mm													
Mod.	A	B	B II	C	D	E	F	G	H	I	I II	L	L II
<b>FSI1</b>	1/2" bspp 3/4" bspp	60	50	232	25	48	22	75	10,5	82	90	48	69

# FSI2-3-4

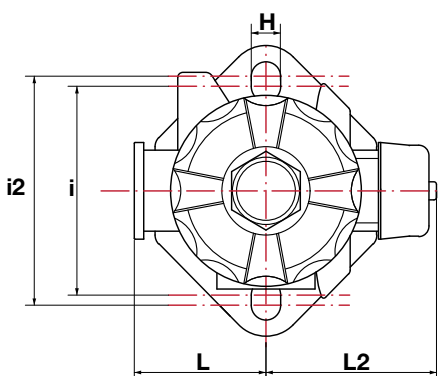
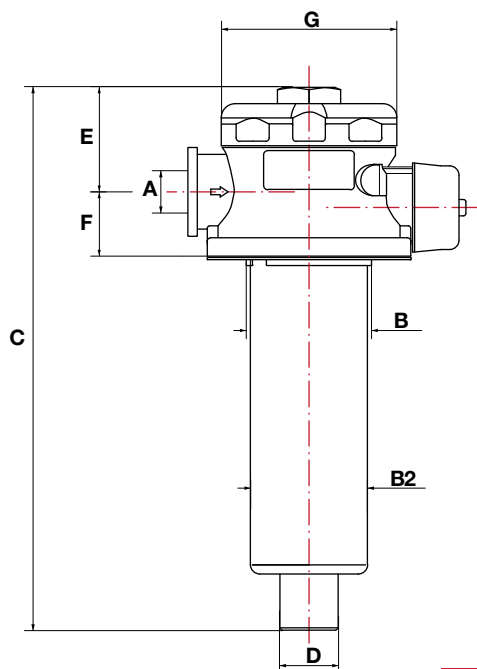

DIMENSIONI mm - DIMENSIONS mm													
Mod.	A	B	B II	C	D	E	F	G	H	I	I II	L	L2
<b>FSI2</b>	3/4" bspp 1" bspp 1/4" bspp	86	80	210	27,5	67	40	110	8,5	110	115	68,5	93,5
<b>FSI3</b>		86	80	255	27,5	67	40	110	8,5	110	115	68,5	93,5
<b>FSI4</b>		86	80	420	27,5	67	40	110	8,5	110	115	68,5	93,5

# COME ORDINARE UN FILTRO COMPLETO:

HOW TO ORDER A COMPLETE FILTER:

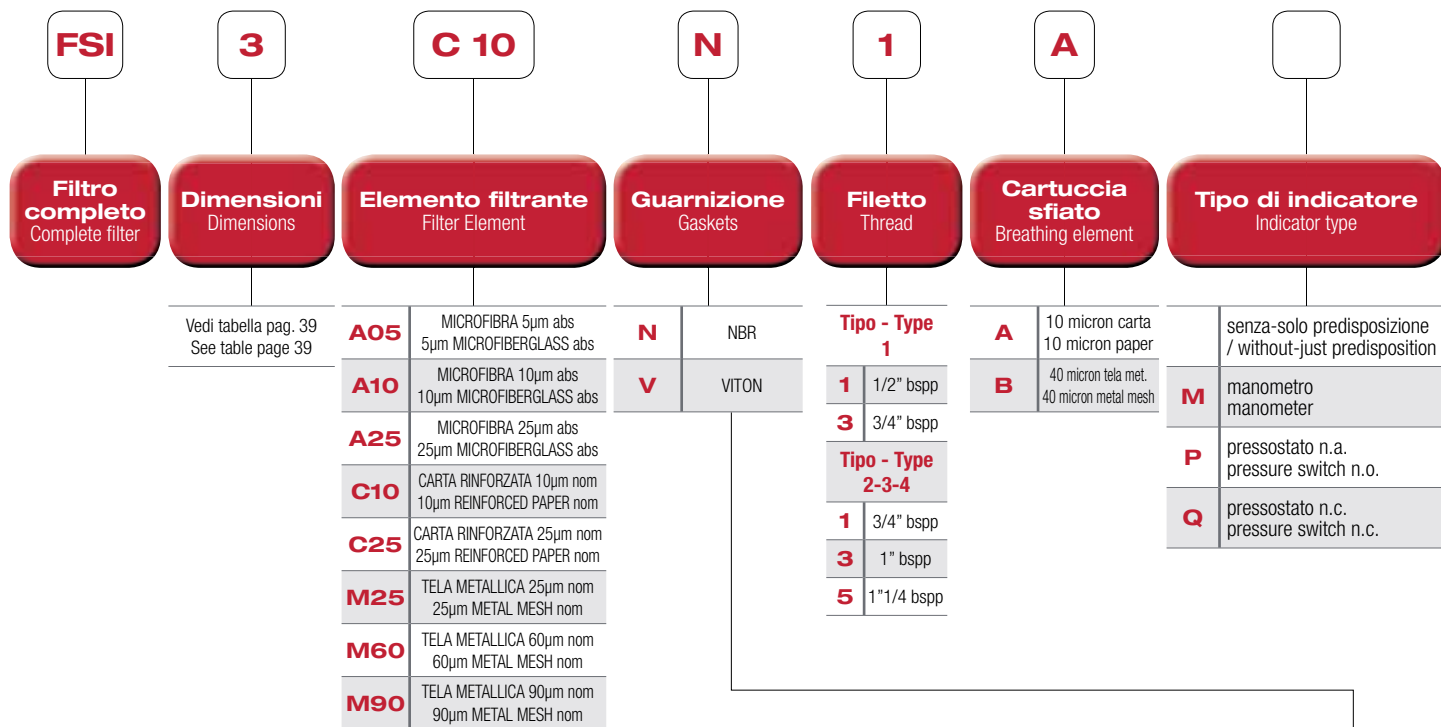

# COME ORDINARE LA CARTUCCIA DI RICAMBIO:

HOW TO ORDER THE REPLACEMENT ELEMENT:

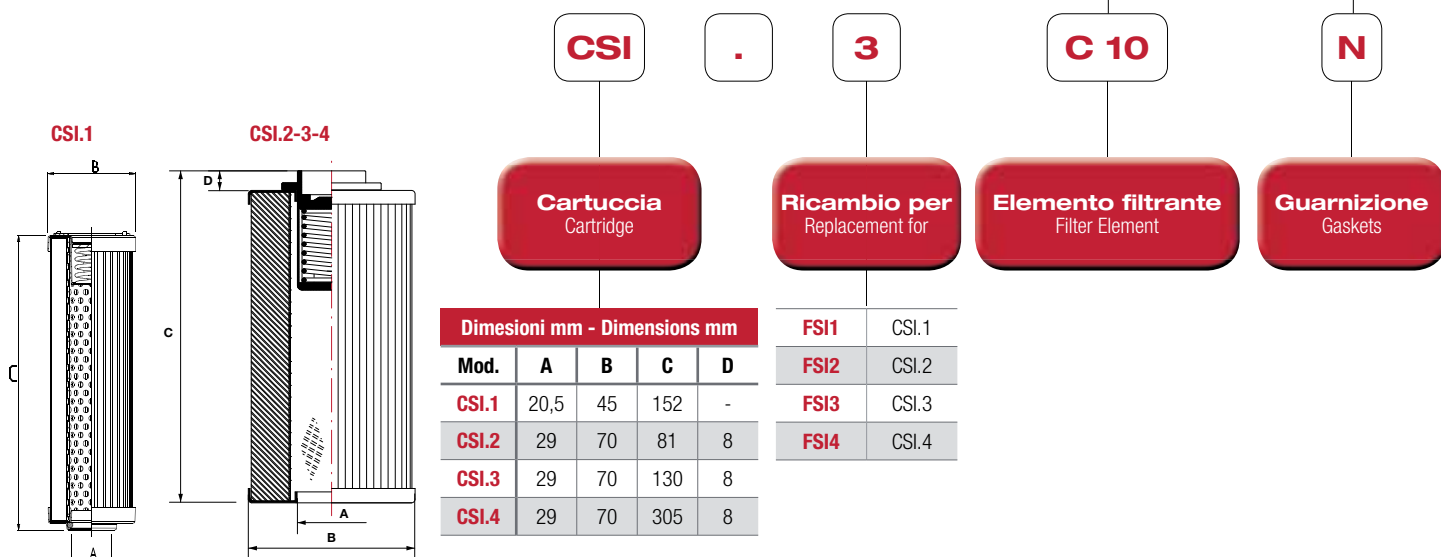



### Portate FSI al ritorno\*\*

Portate in l/min. rilevate con Dp=0.4 - 0.5 bar

### FSI Flow rates on return line\*\*

Flow rate in l/min. measured with Dp=0.4 - 0.5 bar

### Filtredurchfluß FSI im Rücklauf\*\*

Filterdurchfluß in l/min. gemessen bei Dp=0.4 - 0.5 bar

### Débites FSI au retour\*\*

Débites en l/min. mesurés avec Dp=0.4 - 0.5 bar

### Caudales FSI retorno\*\*

Débites en l/min. mesurés avec Dp=0.4 - 0.5 bar

ELEMENTO FILTRANTE FILTERING ELEMENT	MICROFIBRA / FIBERGLASS				CARTA / PAPER		TELA METALLICA WIRE MESH			
	Mod.	FILETTO THREAD BSPP	A05 5 MICRON ABS	A10 10 MICRON ABS	A25 25 MICRON ABS	C10 10 MICRON NOM	C25 25 MICRON NOM	M25 25 MICRON NOM	M60 60 MICRON NOM	M90 90 MICRON NOM
FSI1	1/2"		30	30	35	30	35	35	35	35
	3/4"		35	40	50	45	55	55	60	60
FSI2	3/4"		35	45	55	55	75	65	85	90
	1"		35	45	55	55	85	65	85	95
	1"1/4		35	45	55	55	85	65	90	100
FSI3	3/4"		55	65	75	75	95	75	90	95
	1"		55	65	75	75	100	85	100	105
	1"1/4		55	65	80	75	105	85	105	110
FSI4	3/4"		95	100	115	115	130	115	125	130
	1"		105	120	135	135	155	135	155	160
	1"1/4		110	125	145	145	175	145	170	180

\*\* Portate rilevate con olio avente viscosità cinematica 30 cst e densità 0,86 kg/dm<sup>3</sup>.

\*\* Flow rates measured with oil of 30 cst kinematic viscosity and 0,86 kg/dm<sup>3</sup> density.

• Compatibilità con fluidi: oli minerali (HH-HL-HM-HR-HV-HG) e fluidi sintetici (HS-HFDR-HFDU-HFDS).

• Fluid compatibility: mineral oil (HH-HL-HM-HR-HV-HG) and synthetic fluids (HS-HFDR-HFDU-HFDS).

## INDICATORI INTASAMENTO

CLOGGING INDICATORS - VERSCHMUTZUNGSANZEIGEN - INDICATEURS DE COLMAGE - INDICADORES DE SUCIEDAD

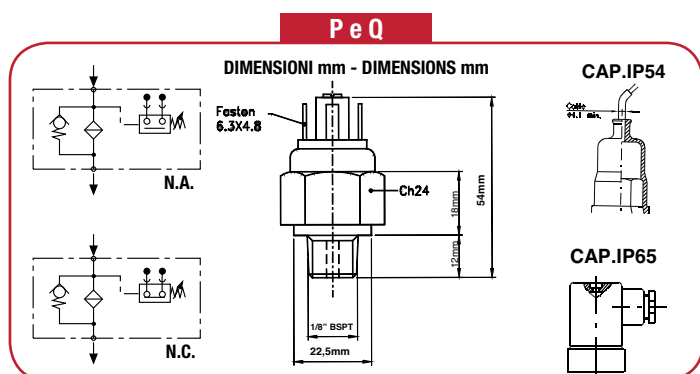
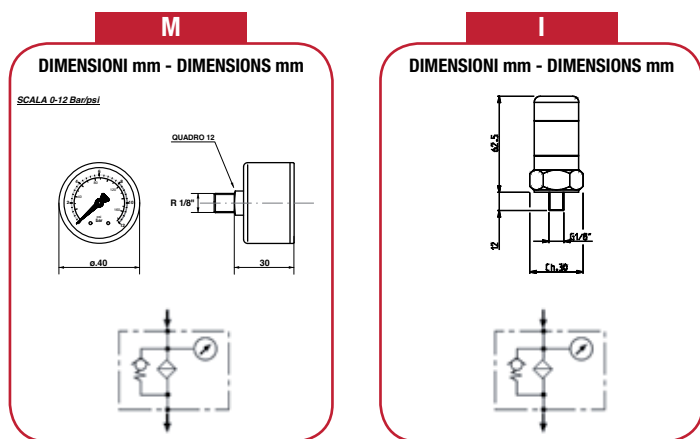

SERIE SERIES	TARATURA SETTING	TIPO - TYPE
M	0÷ 12 bar	Manometro Pressure gauge Manometer Manomètre Manometro
I	1,5 bar	Pressostato visivo Visual pressure indicator Optisch Differenzdruckanzeige Pressostat visuel Presostato visual
P	1,5 bar	Pressostato N.A. (Max 240V/0,4A) / (48V/0,5A) Pressure switch N.O. (Max 240V/0,4A) / (48V/0,5A) Druckschalter N.O. (Max 240V/0,4A) / (48V/0,5A) Pressostat N.O. (Max 240V/0,4A) / (48V/0,5A) Presostato N.A. (Max 240V/0,4A) / (48V/0,5A)
Q	1,5 bar	Pressostato N.C. (Max 240V/0,4A) / (48V/0,5A) Pressure switch N.C. (Max 240V/0,4A) / (48V/0,5A) Druckschalter N.C. (Max 240V/0,4A) / (48V/0,5A) Pressostat N.F. (Max 240V/0,4A) / (48V/0,5A) Presostato N.C. (Max 240V/0,4A) / (48V/0,5A)

# SERIE HR

## IT Filtri avvitabili al ritorno per montaggio diretto sul serbatoio.

### CARATTERISTICHE TECNICHE:

- Testata di supporto: fusione di alluminio.
- Valvola by-pass: Apertura 1,7 bar.
- Cartuccia avvitabile: struttura in acciaio zincato. Elemento filtrante in carta.
- Attacchi disponibili standard: 3/4" bspp (mod. 1-2) o 1"1/2 bspp (mod. 3-4).
- Elementi filtranti disponibili standard: 10-25 Micron nom. carta. Altre filtrazioni su richiesta.
- Guarnizioni: standard Buna-N. Su richiesta Viton.
- Temperatura esercizio: da -30°C a +110°C.
- Pressione di esercizio: 12 bar.
- Pressione di scoppio: 25 bar.
- Pressione di collasso cartuccia: 5 bar.
- Test eseguiti secondo normative: ISO 2941 / ISO 3724 / ISO 3968.

## EN Tank-top return line Spin-on filters

### TECHNICAL FEATURES:

- Supporting head: aluminium die-casting.
- Opening 1,7 bar.
- Spin-on element: galvanized steel structure. Filter element in paper.
- Standard available threads: 3/4" bspp (mod. 1-2) or 1"1/2 bspp (mod. 3-4).
- Standard available filter elements: 10-25 Micron nom. paper. Other filter elements upon request.
- Seals: Buna-N standard. Viton upon request.
- Operating temperature: -30°C +110°C.
- Operating pressure: 12 bar.
- Burst pressure: 25 bar.
- Element collapse pressure: 5 bar.
- Tested according standards: ISO 2941 / ISO 3724 / ISO 3968.

## D Tankaufbau spin-on Filter (Rücklauf-)

### TECHNISCHE DATEN:

- Filterkopf: Aluminium-Druckguss.
- By-pass Ventil: Eröffnung 1,7 bar.
- Spin-on element: galvanisierte Stahlkonstruktion. Papierfilterelemente.
- Standard verfügbaren Anschlußen: 3/4" bspp (Mod. 1-2) oder 1" 1/2 bspp (Mod. 3-4).
- Standard verfügbaren Filterelemente: 10-25 Mikron nom. Papier. Weitere Materialien auf Anfrage erhältlich.
- Dichtungen: Buna-N Standard. Viton auf Wunsch.
- Betriebstemperatur: von -30°C bis +110°C.
- Betriebsdruck: 12 bar.
- Berstdruck: 25 bar.
- Patronekollapsdrücke: 5 bar.
- Test nach Normen: ISO 2941 / ISO 3724 / ISO 3968.

## FR Filtres à visser (spin-on) pour montage direct au réservoir (retour).

### CARACTERISTIQUES TECHNIQUES:

- Tête-support: fusion d'aluminium.
- Clapet by-pass: Ouverture 1,7 bar.
- Cartouche à visser: structure en acier galvanisé. Élément filtrant en papier.
- Connexions standard disponibles: 3/4" bspp (modèle 1-2) ou 1"1/2 bspp (modèle 3-4).
- Éléments filtrants standard disponibles: 10-25 Micron nom. papier. Autres filtrations sur demande.
- Joints: Buna-N standard. Viton sur demande.
- Température de travail: de -30°C à +110°C.
- Pression de service: 12 bar.
- Pression d'éclatement: 25 bar.
- Pression d'écrasement élément filtrant: 5 bar.
- Test selon standards: ISO 2941 / ISO 3724 / ISO 3968.

## ES Filtros roscados al retorno para montaje directo al depósito.

### CARACTERÍSTICAS TÉCNICAS:

- Cabeza de soporte: aluminio fundido.
- Válvula by-pass: Apertura 1,7 bar.
- Cartucho roscado: cuerpo en acero ceneado. Elemento filtrante en papel.
- Conexiones disponibles estándar: 3/4" bspp (mod. 1-2) ó 1"1/2 bspp (mod. 3-4).
- Elemento filtrante disponible estándar: 10-25 micras nom. en Papel. Otras filtraciones bajo pedido.
- Juntas: estándar Buna-N. Bajo pedido Viton.
- Temperatura de trabajo: de -30°C a +110°C.
- Presión de trabajo: 12 bar.
- Presión de rotura: 25 bar.
- Presión de colapso cartucho: 5 bar.
- Test efectuado según normativa: ISO 2941 / ISO 3724 / ISO 3968.

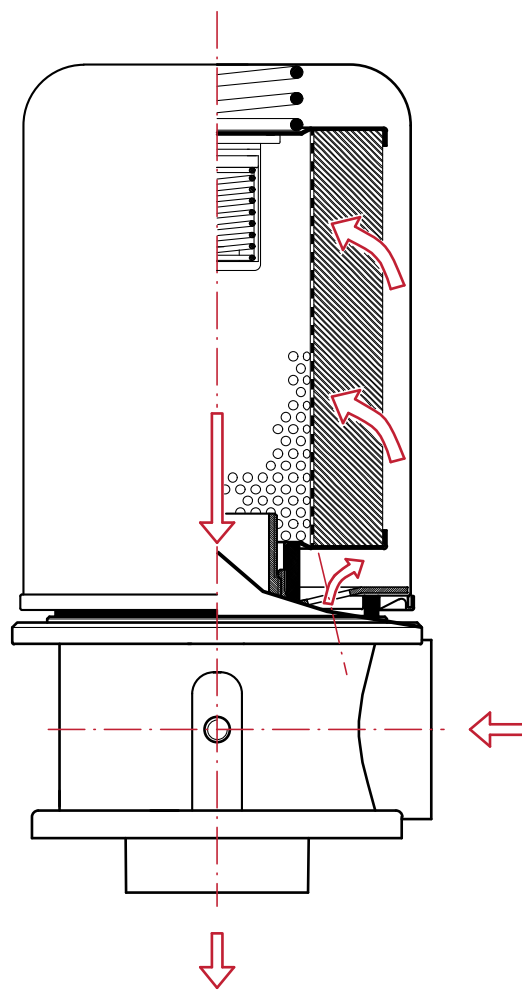

# HR101-102

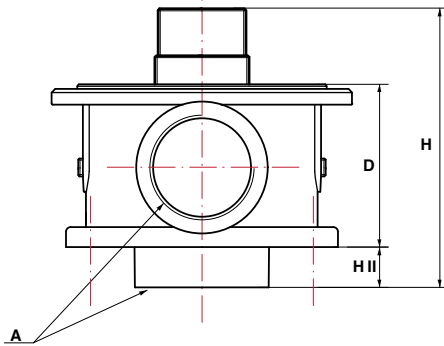
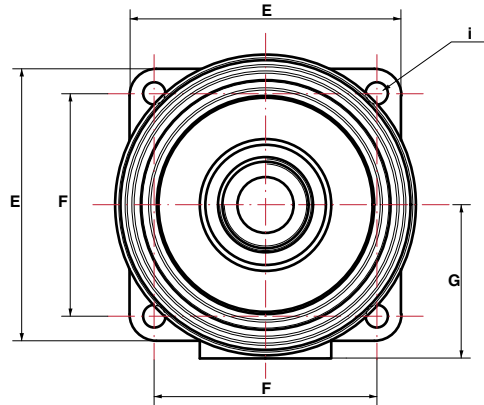
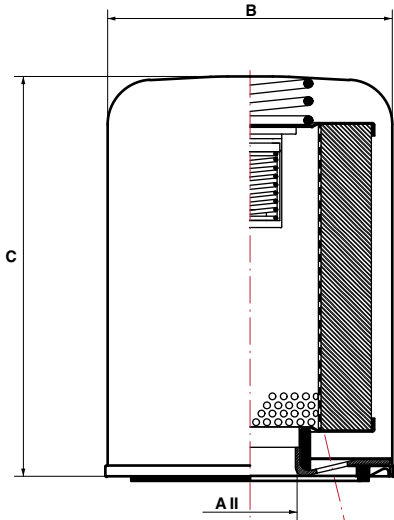

DIMENSIONI mm - DIMENSIONS mm											
Mod.	A	A II	B	C	D	E	F	G	H	H II	i
HR101	3/4" bspp	3/4" bspp	95	145	50	90	70	50	80	16	Ø 7
HR102	3/4" bspp	3/4" bspp	95	190	50	90	70	50	80	16	Ø 7

# HR203-204

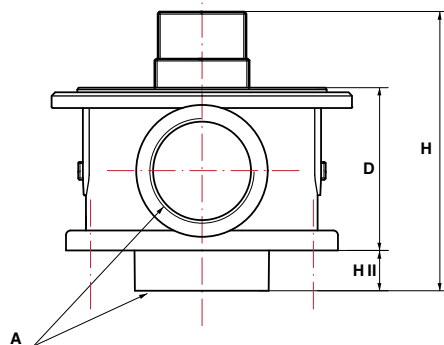
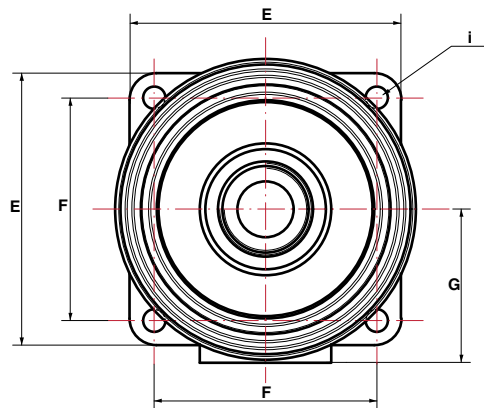
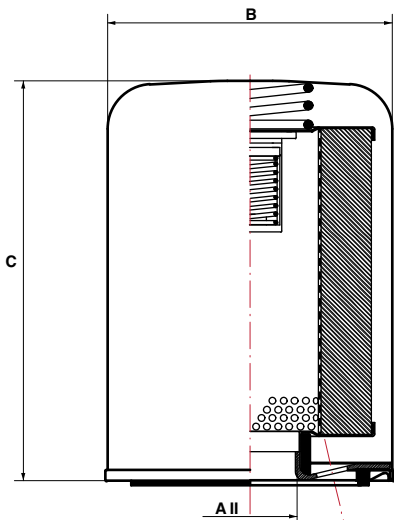

DIMENSIONI mm - DIMENSIONS mm											
Mod.	A	A II	B	C	D	E	F	G	H	H II	i
HR203	1"1/2 bspp	1"1/4 bspp	128	180	73	123	100	70	125	18	Ø 9
HR204	1"1/2 bspp	1"1/4 bspp	128	226	73	123	100	70	125	18	Ø 9



# COME ORDINARE UN FILTRO COMPLETO:

HOW TO ORDER A COMPLETE FILTER:

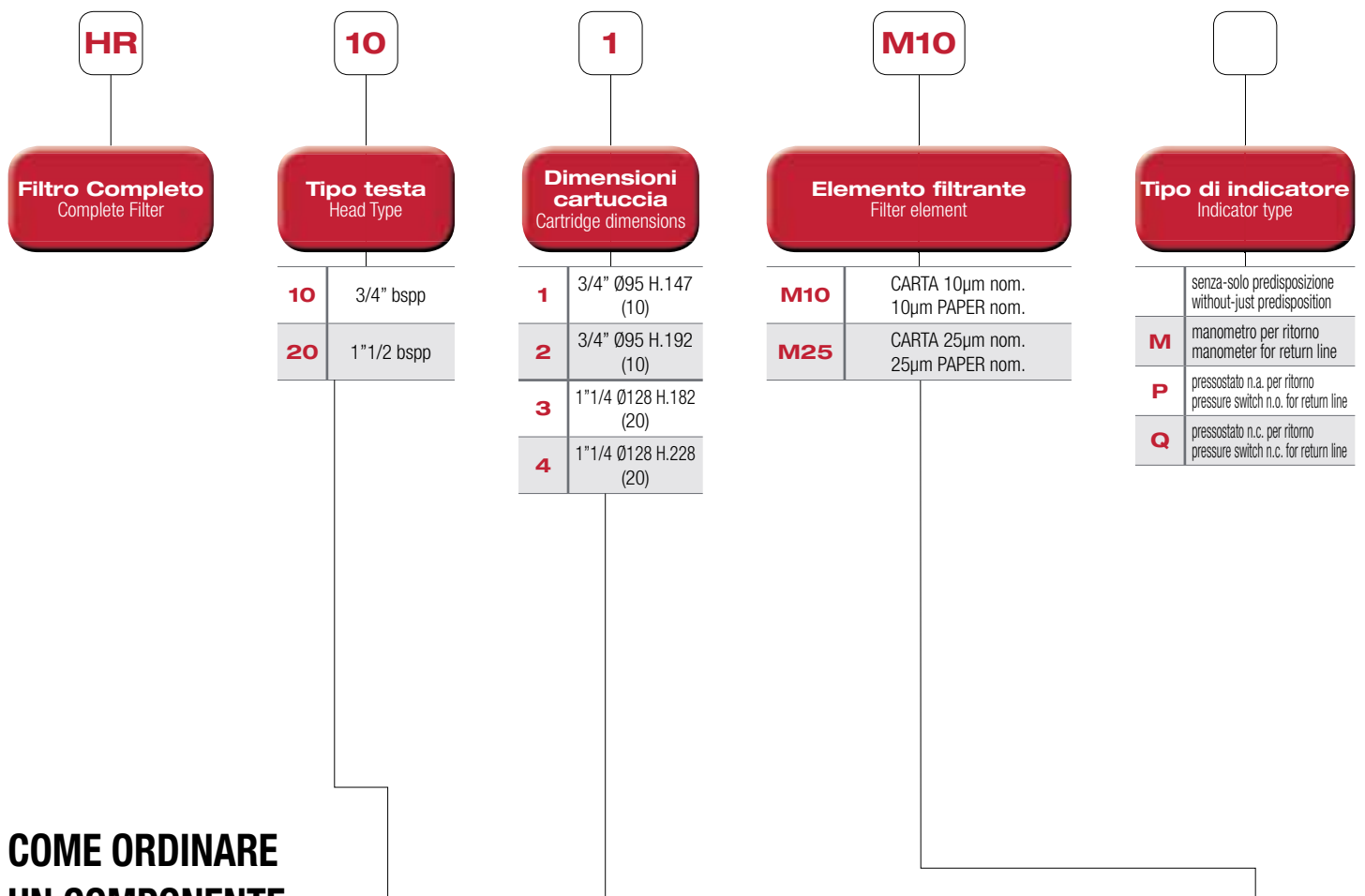

# COME ORDINARE UN COMPONENTE:

HOW TO ORDER A COMPONENT:

⇒ **TESTA:**  
HEAD:

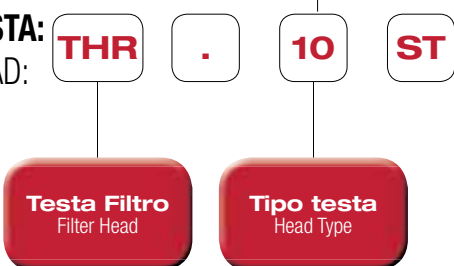

⇒ **CARTUCCIA:**  
CARTRIDGE:

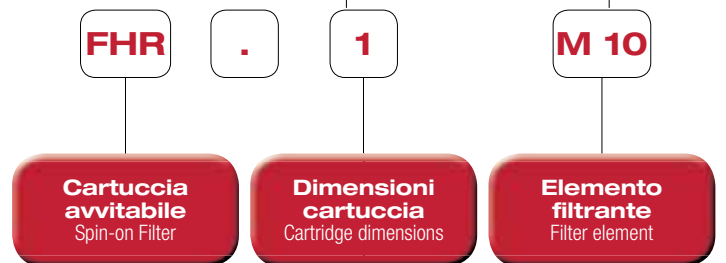
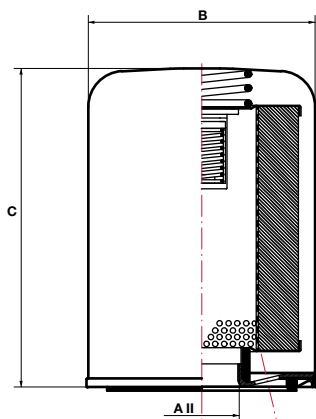

Dimensioni mm - Dimensions mm			
Mod.	A II	B	C
<b>FHR.1</b>	3/4" bspp	95	147
<b>FHR.2</b>	3/4" bspp	95	192
<b>FHR.3</b>	1"1/4 bspp	128	182
<b>FHR.4</b>	1"1/4 bspp	128	228

## Portate HR al ritorno\*\*

Portate in l/min. rilevate con Dp=0.4 - 0.5 bar

## HR Flow rates on return line\*\*

Flow rate in l/min. measured with Dp=0.4 - 0.5 bar

## Filtredurchfluß HR im Rücklauf\*\*

Filterdurchfluß in l/min. gemessen bei Dp=0.4 - 0.5 bar

## Débits HR au retour\*\*

Débits en l/min. mesurés avec Dp=0.4 - 0.5 bar

## Caudales HR retorno\*\*

Débits en l/min. mesurés avec Dp=0.4 - 0.5 bar

ELEMENTO FILTRANTE FILTERING ELEMENT	CARTA / PAPER	
	M10 10 MICRON NOM	M25 25 MICRON NOM
Mod. <b>HR101</b>	68	73
<b>HR102</b>	74	80
<b>HR203</b>	130	170
<b>HR204</b>	150	188

\*\* Portate rilevate con olio avente viscosità cinematica di 30 cSt e densità 0.86 kg/dm<sup>3</sup>

\*\* Flow rates measured with oil of 30 cSt kinematic viscosity and 0.86 kg/dm<sup>3</sup>

- Compatibilità con fluidi: oli minerali (HH-HL-HM-HR-HV-HG) e fluidi sintetici (HS-HFDR-HFDU-HFDS).
- Fluid compatibility: mineral oil (HH-HL-HM-HR-HV-HG) and synthetic fluids (HS-HFDR-HFDU-HFDS).

## INDICATORI INTASAMENTO

CLOGGING INDICATORS - VERSCHMUTZUNGSANZEIGEN - INDICATEURS DE COLMAGE - INDICADORES DE SUCIEDAD

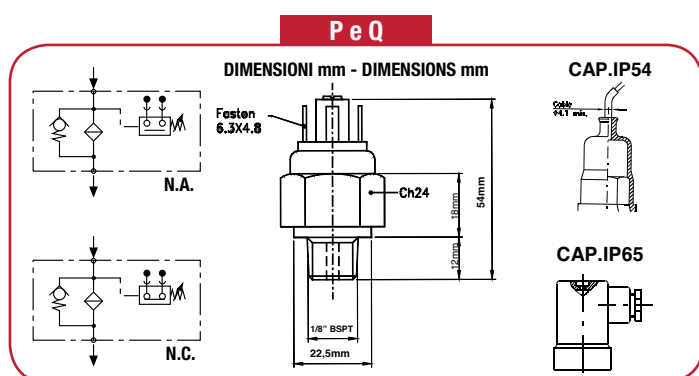
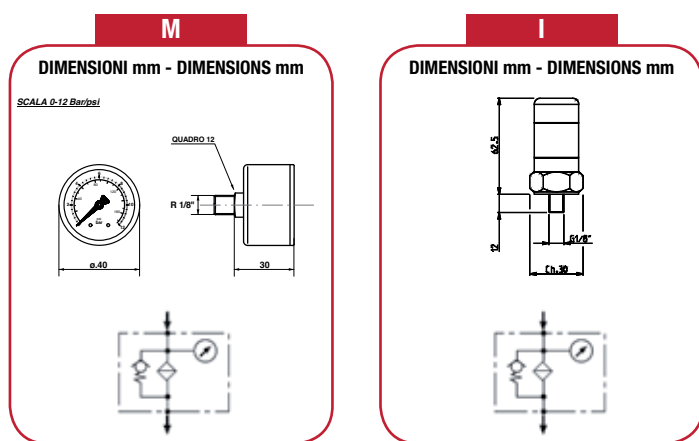

SERIE SERIES	TARATURA SETTING	TIPO - TYPE
<b>M</b>	0÷ 12 bar	Manometro Pressure gauge Manomèter Manómetro
<b>I</b>	1,5 bar	Pressostato visivo Visual pressure indicator Optisch Differenzdruckanzeige Pressostat visuel Presostato visual
<b>P</b>	1,5 bar	Pressostato N.A. (Max 240V/0,4A) / (48V/0,5A) Pressure switch N.O. (Max 240V/0,4A) / (48V/0,5A) Druckschalter N.O. (Max 240V/0,4A) / (48V/0,5A) Pressostat N.O. (Max 240V/0,4A) / (48V/0,5A) Presostato N.A. (Max 240V/0,4A) / (48V/0,5A)
<b>Q</b>	1,5 bar	Pressostato N.C. (Max 240V/0,4A) / (48V/0,5A) Pressure switch N.C. (Max 240V/0,4A) / (48V/0,5A) Druckschalter N.C. (Max 240V/0,4A) / (48V/0,5A) Pressostat N.F. (Max 240V/0,4A) / (48V/0,5A) Presostato N.C. (Max 240V/0,4A) / (48V/0,5A)

# SERIE FAR

## IT Filtri aspirazione e ritorno per montaggio semimmersi nel serbatoio.

### CARATTERISTICHE TECNICHE:

- Coperchio: fusione in alluminio.
- Corpo filtro: fusione in alluminio.
- Valvola by-pass: Apertura standard 0,25 bar (aspirazione) / 1,7 bar (ritorno).
- Attacchi disponibili standard: 1/2"-3/4"-1"-1"1/4 bspp.
- Elementi filtranti disponibili standard: 10-25 Micron nom. carta / 60-125 Micron nom. tela metallica. Altre filtrazioni su richiesta.
- Guarnizioni: standard Buna-N. Su richiesta Viton.
- Temperatura esercizio: da -25°C a +110°C.
- Pressione di esercizio: 15 bar.
- Pressione di scoppio: 45 bar.
- Pressione di collasso cartuccia: 10 bar.
- Test eseguiti secondo normative: ISO 2941 / ISO 3724 / ISO 3968.

## EN Suction & return line tank-top filters.

### TECHNICAL FEATURES:

- Cover: aluminium die-casting.
- Filter body: aluminium die-casting.
- By-pass valve: Standard opening 0,25 bar (suction) / 1,7 bar (return).
- Standard available threads: 1/2"-3/4"-1"-1"1/4 bspp.
- Standard available filter elements: 10-25 Micron nom. paper / 60-125 Micron nom. wire mesh. Other filter elements upon request.
- Seals: Buna-N standard. Viton upon request.
- Operating temperature: -25°C +110°C.
- Operating pressure: 15 bar.
- Burst pressure: 45 bar.
- Element collapse pressure: 10 bar.
- Tested according standards: ISO 2941 / ISO 3724 / ISO 3968.

## D Saug & Rücklauf-Tankeinbaufilter.

### TECHNISCHE DATEN:

- Deckel: Aluminium-Druckguss.
- Filtergehäuse: Aluminium-Druckguss.
- By-pass Ventil: Standardöffnung 0,25 (Saug-) / 1,7 bar (Rücklauf).
- Standard verfügbaren Anschlüssen: 1/2"-3/4"-1"-1"1/4 bspp.
- Standard verfügbaren Filterelemente: 10-25 Mikron nom. Papier / 60-125 Mikron nom. Drahtgewebe. Weitere Materialien auf Anfrage erhältlich.
- Dichtungen: Buna-N Standard. Viton auf Wunsch.
- Betriebstemperatur: von -25°C bis +110°C.
- Betriebsdruck: 15 bar.
- Berstdruck: 45 bar.
- Patronekollapsdrücke: 10 bar.
- Test nach Normen: ISO 2941 / ISO 3724 / ISO 3968.

## FR Filtres aspiration et retour semi-immergés dans le réservoir.

### CARACTERISTIQUES TECHNIQUES:

- Couvercle: fusion d'aluminium.
- Corp filtre: fusion d'aluminium.
- Clapet by-pass: Ouverture standard 0,25 bar (aspiration) / 1,7 bar (retour).
- Connexions standard disponibles: 1/2"-3/4"-1"-1"1/4 bspp.
- Eléments filtrants standard disponibles: 10-25 Micron nom. papier / 60-125 Micron nom. toile met. Autres filtrations sur demande.
- Joints: Buna-N standard. Viton sur demande.
- Temperature de travaille: de -25°C à +110°C.
- Pression de service: 15 bar.
- Pression d'éclatement: 45 bar.
- Pression d'écrasement élément filtrant: 10 bar.
- Test selon standards: ISO 2941 / ISO 3724 / ISO 3968.

## ES Filtros aspiración y retorno para montaje semi-inmerso en deposito .

### CARACTERÍSTICAS TÉCNICAS:

- Tapa filtro: fundición de aluminio.
- Cuerpo filtro: fundición de aluminio.
- Válvula de by-pass Apertura estándar 0,25 bar (aspiración) / 1,7 bar (retorno).
- Conexiones disponibles estándar: 1/2"-3/4"-1"-1"1/4 bspp.
- Elemento filtrante disp. estándar: 10-25 micras nom. en papel / 60-125 micras nom. en tela metálica. Otras filtraciones bajo pedido.
- Juntas: standar Buna-N. Bajo pedido Viton.
- Temperatura de trabajo: de -25°C a +110°C.
- Presión de trabajo: 15 bar
- Presión de rotura: 45 bar
- Presión de colapso del cartucho: 10 bar.
- Prueba realizada según normativa: ISO 2941 / ISO 3724 / ISO 3968.

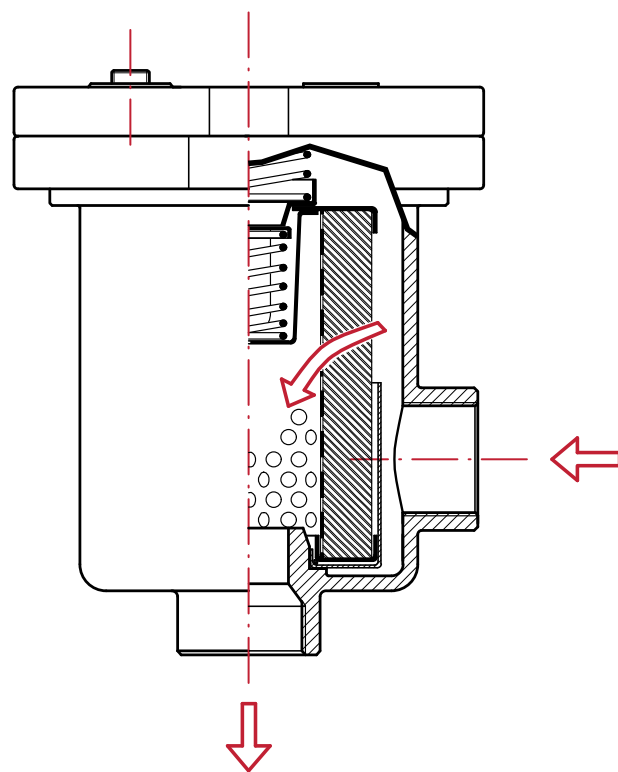



# FAR.05-10-15

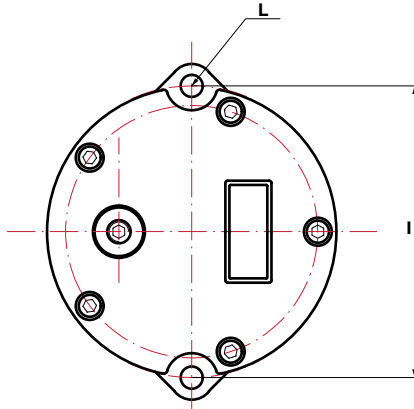
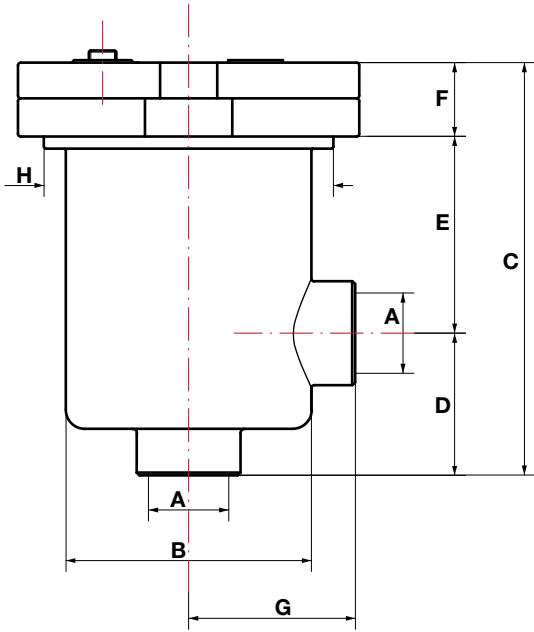

## 2 FORI FISSAGGIO - 2 FIXING HOLES

DIMENSIONI mm - DIMENSIONS mm

Mod.	A	B	C	D	E	F	G	H	I	L
<b>FAR.05</b>	1/2" bspp	71	125	40	66	19	48	80	100	Ø 7,5
<b>FAR.10</b>	3/4" bspp	88	151	52	72	27	59	106	125	Ø 9,5
<b>FAR.15</b>	1" bspp	88	195	52	116	27	59	106	125	Ø 9,5

# FAR.20

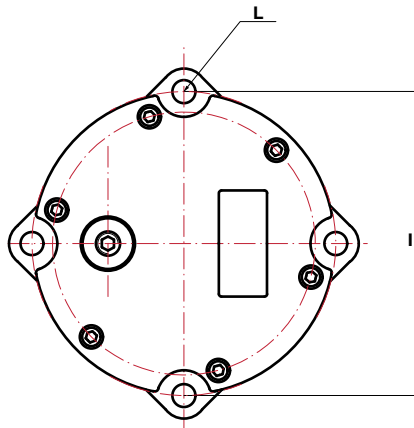
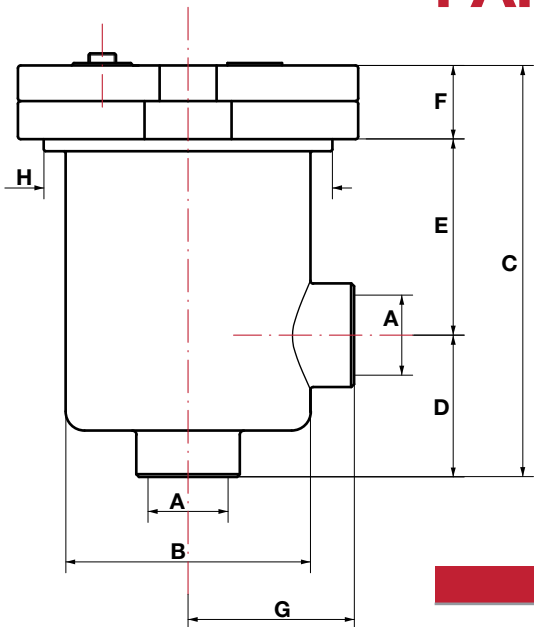

## 4 FORI FISSAGGIO - 4 FIXING HOLES

DIMENSIONI mm - DIMENSIONS mm

Mod.	A	B	C	D	E	F	G	H	I	L
<b>FAR.20</b>	1" 1/4 bspp	138	275	62	180	33	83,5	147	175	Ø 9,5

# COME ORDINARE UN FILTRO COMPLETO:

HOW TO ORDER A COMPLETE FILTER:

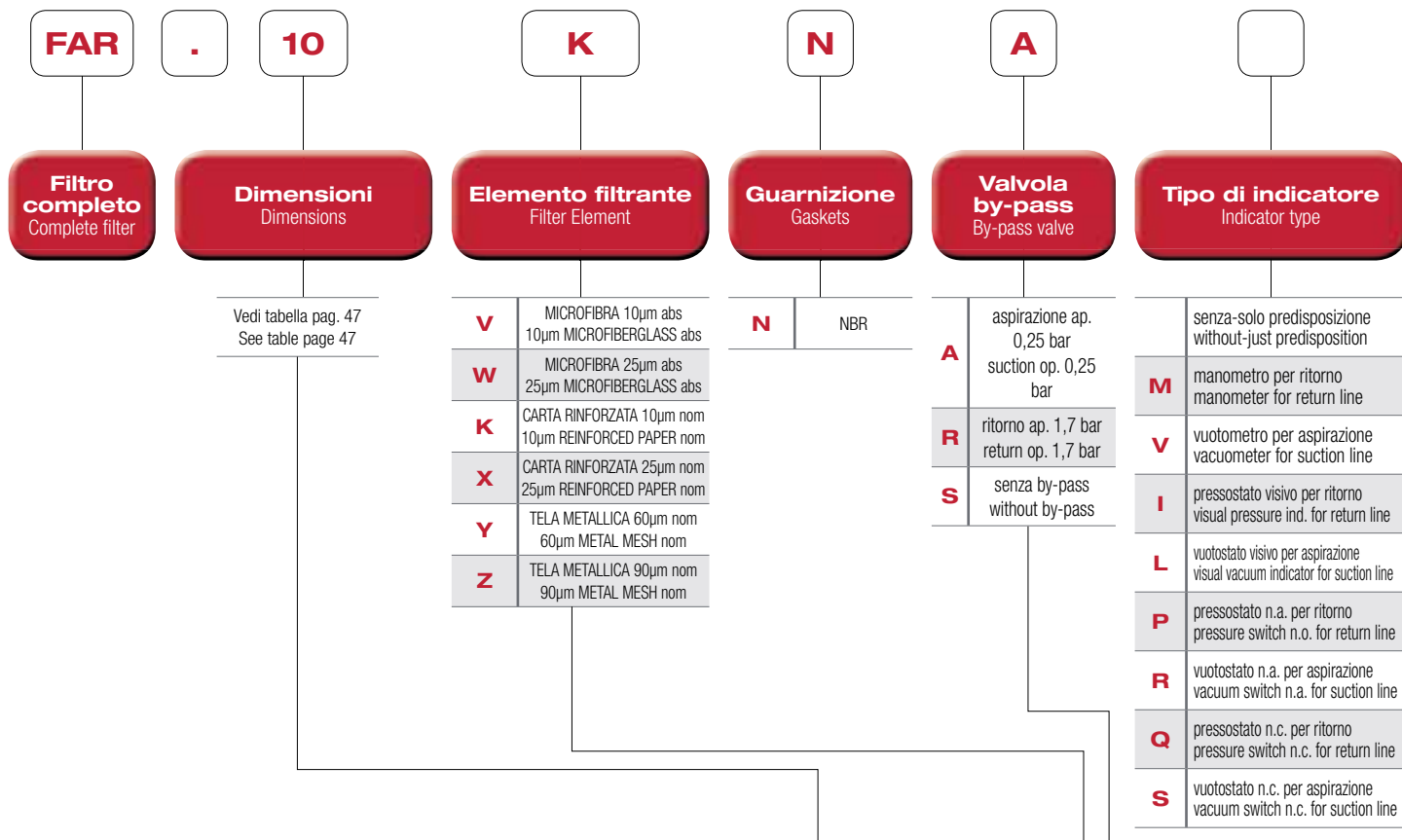

# COME ORDINARE LA CARTUCCIA DI RICAMBIO:

HOW TO ORDER THE REPLACEMENT ELEMENT:

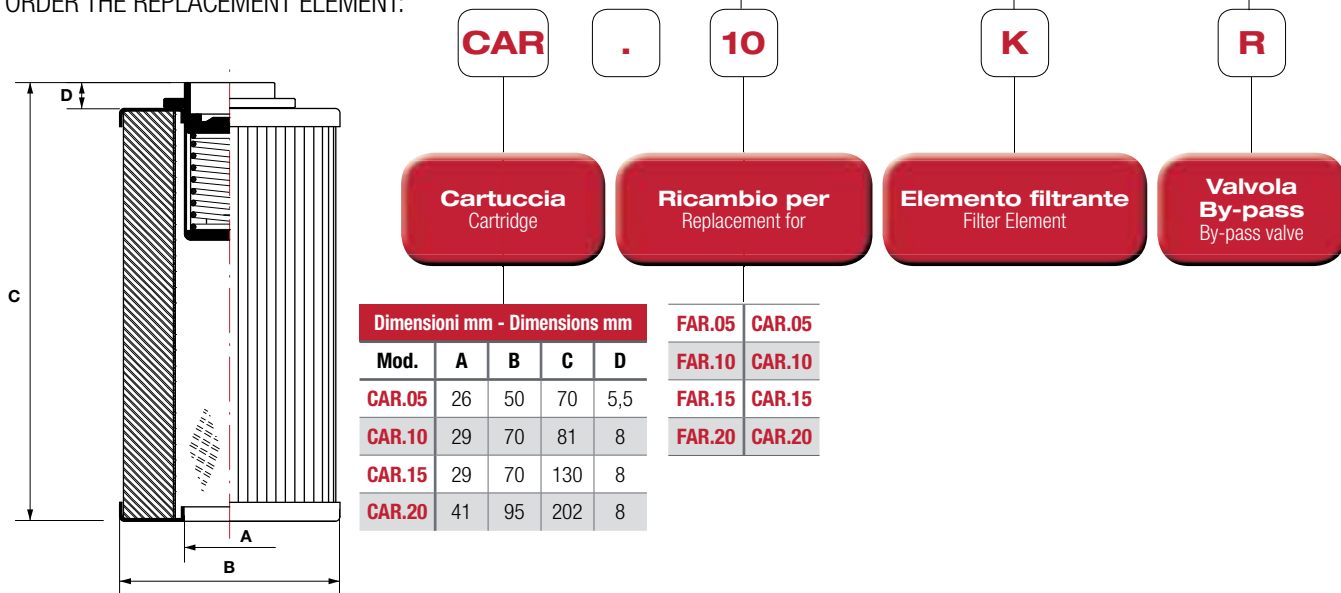

# PROTEZIONE IN PLASTICA PER CARTUCCIA (dal flusso in entrata):

ELEMENT PLASTIC PROTECTION (from inflow):

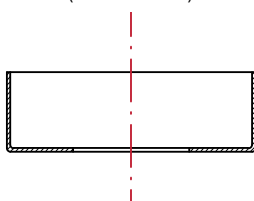

CODICE - CODE	CARTUCCIA - ELEMENT
PV9.05564	CAR.05
PV9.05565	CAR.10 - CAR.15
PV9.05563	CAR.20

### Portate FAR in aspirazione\*\*

Portate in l/min. rilevate con Dp=0.05 - 0.10 bar

### FAR suction flow rates\*\*

Flow rate in l/min. measured with Dp=0.05 - 0.10 bar

### Filtredurchfluß (-saug) FAR\*\*

Filterdurchfluß in l/min. gemessen bei Dp=0.05 - 0.10 bar

### Débits FAR à l'aspiration\*\*

Débits en l/min. mesurés avec Dp=0.05 - 0.10 bar

### Caudales FAR aspiración\*\*

Débits en l/min. mesurés avec Dp=0.05 - 0.10 bar

ELEMENTO FILTRANTE FILTERING ELEMENT	MICROFIBRA / FIBERGLASS		CARTA / PAPER		TELA METALLICA WIRE MESH		
	Mod.	V - 10 MICRON ABS	W - 25 MICRON ABS	K - 10 MICRON NOM	X - 25 MICRON NOM	Y - 60 MICRON NOM	Z - 90 MICRON NOM
<b>FAR.05</b>		7	8	9	10	13	15
<b>FAR.10</b>		13	15	18	20	28	30
<b>FAR.15</b>		27	30	33	35	48	50
<b>FAR.20</b>		50	54	58	60	87	90

### Portate FAR al ritorno\*\*

Portate in l/min. rilevate con Dp=0.4

### FAR Flow rates on return line\*\*

Flow rate in l/min. measured with Dp=0.4

### Filtredurchfluß FAR im Rücklauf\*\*

Filterdurchfluß in l/min. gemessen bei Dp=0.4

### Débits FAR au retour\*\*

Débits en l/min. mesurés avec Dp=0.4

### Caudales FAR retorno\*\*

Débits en l/min. mesurés avec Dp=0.4

ELEMENTO FILTRANTE FILTERING ELEMENT	MICROFIBRA / FIBERGLASS		CARTA / PAPER		TELA METALLICA WIRE MESH		
	Mod.	V - 10 MICRON ABS	W - 25 MICRON ABS	K - 10 MICRON NOM	X - 25 MICRON NOM	Y - 60 MICRON NOM	Z - 90 MICRON NOM
<b>FAR.05</b>		13	15	18	20	28	30
<b>FAR.10</b>		32	35	45	50	63	68
<b>FAR.15</b>		57	60	70	75	95	100
<b>FAR.20</b>		115	120	130	140	180	190

\*\* Portate rilevate con olio avente viscosità cinematica di 30 cSt e densità 0.86 kg/dm<sup>3</sup>

\*\* Flow rates measured with oil with 30 cSt kinematic viscosity and 0.86 kg/dm<sup>3</sup>

• Compatibilità con fluidi: oli minerali (HH-HL-HM-HR-HV-HG) e fluidi sintetici (HS-HFDR-HFDU-HFDS).

• Fluid compatibility: mineral oil (HH-HL-HM-HR-HV-HG) and synthetic fluids (HS-HFDR-HFDU-HFDS).

## INDICATORI INTASAMENTO

CLOGGING INDICATORS - VERSCHMUTZUNGSANZEIGEN - INDICATEURS DE COLMAGE - INDICADORES DE SUCIEDAD

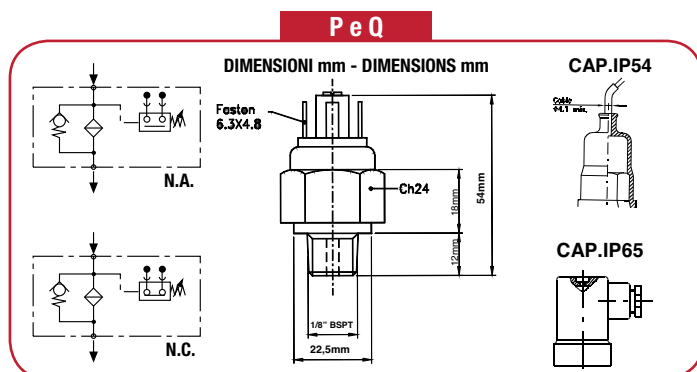
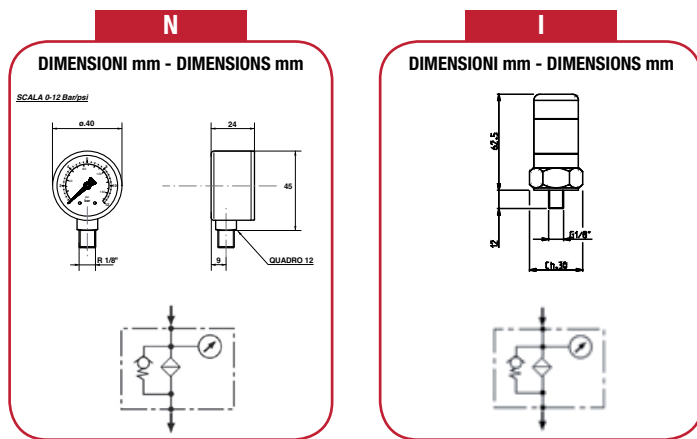

SERIE SERIES	TARATURA SETTING	TIPO - TYPE
<b>N</b>	0 ÷ 12 bar	Manometro Pressure gauge Manometer Manomètre Manometro
<b>I</b>	1,5 bar	Pressostato visivo Visual pressure indicator Optisch Differenzdruckanzeige Pressostat visuel Presostato visual
<b>P</b>	1,5 bar	Pressostato N.A. (Max 240V/0,4A) / (48V/0,5A) Pressure switch N.O. (Max 240V/0,4A) / (48V/0,5A) Druckschalter N.O. (Max 240V/0,4A) / (48V/0,5A) Pressostat N.O. (Max 240V/0,4A) / (48V/0,5A) Presostato N.A. (Max 240V/0,4A) / (48V/0,5A)
<b>Q</b>	1,5 bar	Pressostato N.C. (Max 240V/0,4A) / (48V/0,5A) Pressure switch N.C. (Max 240V/0,4A) / (48V/0,5A) Druckschalter N.C. (Max 240V/0,4A) / (48V/0,5A) Pressostat N.F. (Max 240V/0,4A) / (48V/0,5A) Presostato N.C. (Max 240V/0,4A) / (48V/0,5A)



# Filtri in linea per media ed alta pressione

## SERIE PF 1-2-3-4

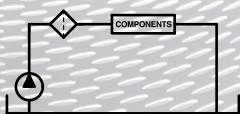

Filtri in mandata  
Delivery filters  
Drückfilter  
Filtres refoulement  
Filtros presion

GB

Medium & high pressure  
in-line filters

D

Mittel & Hochdrückleitungsfilter

FR

Filtres en ligne a moyenne  
et haute pression

ES

Filtros en linea a media  
y alta presion

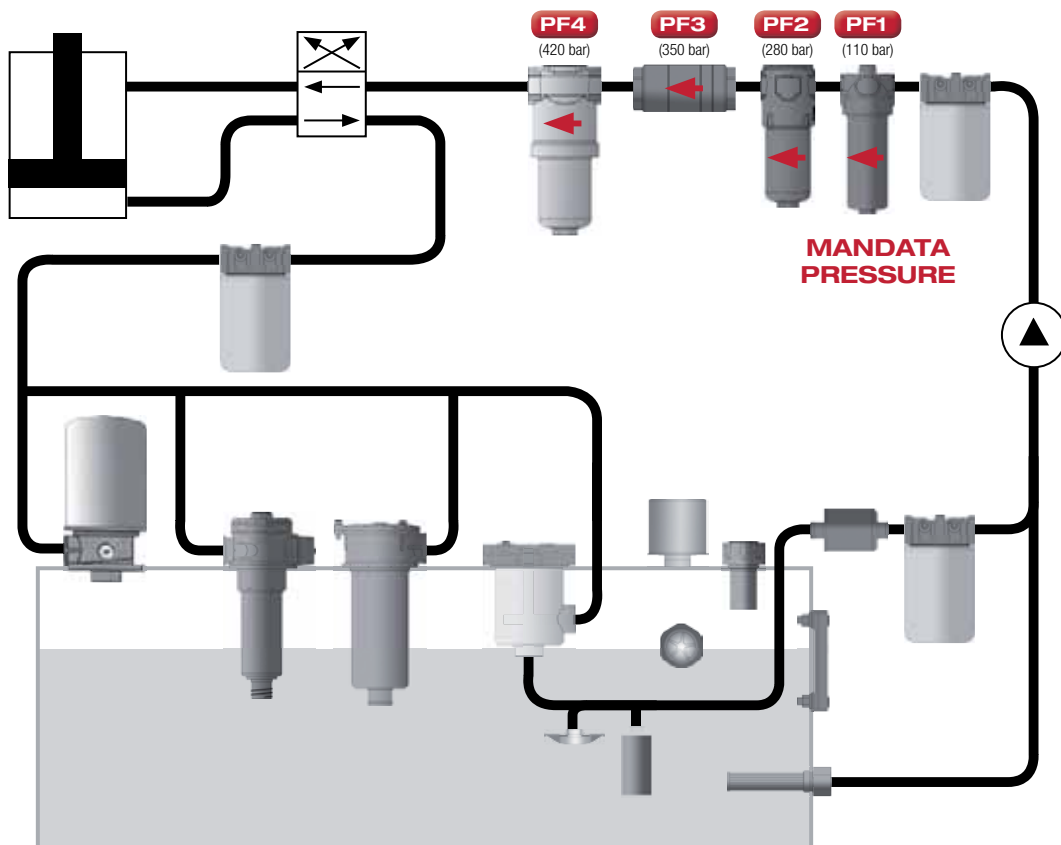

**IT** I filtri serie PF1-PF2-PF3-PF4 vengono utilizzati per montaggio in linea (mandata) lungo il circuito oleodinamico a media ed alta pressione (da 110 a 420 bar), per proteggere i componenti del sistema dalla contaminazione. Questa tipologia di filtri in mandata è indispensabile su circuiti oleodinamici sofisticati e capaci di elevate prestazioni, per i quali è necessaria la massima garanzia di protezione dei componenti sensibili situati a valle del filtro. Si tratta di filtri molto versatili, studiati per le più svariate applicazioni: macchine utensili, agricole, movimento terra, veicoli industriali, applicazioni mobili e stazionarie in genere. Sono disponibili diversi modelli per soddisfare tutte le esigenze, dalle piccole alle grandi portate, con diversi elementi filtranti tali da garantire la massima protezione del circuito.

**GB** PF1-PF2-PF3-PF4 series filters are used in-line (pressure) mounting on medium and high pressure hydraulic circuit (from 110 up to 420 bar), to protect system's components from contamination. This kind of filters is essential on sophisticated hydraulic systems capable of high performances, for which it is necessary to guarantee maximum protection for sensitive components, downstream the filter. It is a very versatile series of filters, designed for various applications: tools, agricultural and earthmoving machines, industrial vehicles, mobile and stationary applications in general. There are several models to meet all needs, from small to large flows, with different filter elements in order to ensure maximum protection to the circuit.

**D** Die Filter der Serie PF1-PF2-PF3-PF4 werden in Mittel- und Hochdruck-Hydraulikleitungen verbaut, um die Systemkomponenten vor Verschmutzung zu schützen. Diese Art Filter ist unentbehrlich für Hochleistungs-Hydrauliksysteme, um maximalen Schutz der empfindlichen Bauteile zu gewährleisten. Die Filterserie findet in den verschiedensten Bereichen Verwendung: In Werkzeugen, Landwirtschaftlichen Fahrzeugen und Maschinen, Baufahrzeugen und -Maschinen, Industriefahrzeugen oder in allgemeinen mobilen- und stationären Anwendungen. Wir bieten Ihnen Modelle in großer Auswahl (kleine bis große Durchflussmengen, verschiedene Filtereinsätze), um auch speziellsten Bedürfnissen gerecht zu werden und Ihre Hydraulikschaltungen jederzeit bestmöglich zu schützen.

**FR** La série de filtres PF1-PF2-PF3-PF4 sont utilisés montés en ligne (pression) sur le circuit hydraulique a moyenne et haute pression, pour protéger de la contamination les composants du système. Ce type de filtre est essentiel pour les systèmes hydrauliques sophistiqués et capables de performances élevées, pour lesquelles il est nécessaire garantir une protection maximale des composants sensibles en aval du filtre. C'est une série très polyvalent de filtres, conçus pour diverses applications: machines outils, agricoles et de chantiers, véhicules industriels, applications mobiles et stationnaires en général. Il existe plusieurs modèles pour répondre à tous les besoins, pour débits petits ou grands, avec différents éléments filtrants, afin d'assurer une protection maximale du circuit.

**ES** Los filtros serie PF1-PF2-PF3-PF4 se utilizan para la línea de montaje (presión) a lo largo del circuito hidráulico a presión media y alta (110 a 420 bar), para proteger los componentes del sistema de la contaminación. Este tipo de filtro es esencial para los sofisticados sistemas hidráulicos capaces de alto rendimiento, para el que es necesario garantizar la máxima protección de componentes sensibles después del filtro. Se trata de filtros muy versátiles estudiados para las mas variadas aplicaciones: máquina herramienta, agrícola, obra pública, vehículos industriales, aplicaciones móviles y estacionarias en general. Están disponibles diversos modelos para satisfacer todas las exigencias, desde pequeños a grandes caudales, con distintos elementos filtrantes tales que garanticen la máxima protección del circuito.

# SERIE PF1 (max. 110 bar)

## IT Filtri in linea a media pressione (max. 110 bar)

### CARATTERISTICHE TECNICHE:

- Testata: fusione di alluminio anodizzato.
- Corpo filtro: fusione di alluminio anodizzato.
- Valvola by-pass: Apertura differenziale 6 bar.
- Attacchi disponibili standard: 1/2" bspp. Filettature speciali su richiesta.
- Elementi filtranti disponibili standard: 3-5-10-25 Micron abs. Microfibra / 10-25 Micron nom. carta. Altre filtrazioni su richiesta.
- Guarnizioni: standard Buna-N. Su richiesta Viton.
- Temperatura esercizio: da -30°C a +90°C (+110°C Viton).
- Portata massima: 90 l/min.
- Pressione di esercizio: 110 bar. Pressione di scoppio: 300 bar.
- Pressione di collasso cartuccia: 21 bar.
- Resistenza a fatica: > 800'000 cicli (0÷110 bar).
- Test eseguiti secondo normative: ISO 2941 / ISO 3724 / ISO 3968.

## GB Medium pressure in-line filters (max. 110 bar)

### TECHNICAL FEATURES:

- Head: anodized aluminium die-casting.
- Filter body: anodized aluminium die-casting.
- By-pass valve: Differential opening 6 bar.
- Standard available threads: 1/2" bspp. Other threads upon request.
- Standard available filter elements: 3-5-10-25 Micron abs. microfiber / 10-25 Micron nom. paper. Other filter elements upon request.
- Seals: Buna-N standard. Viton upon request.
- Operating temperature: -30°C +90°C (+110°C Viton).
- Maximum flow rate: 90 l/min.
- Operating pressure: 110 bar. Burst pressure: 300 bar.
- Element collapse pressure: 21 bar.
- Fatigue resistance: > 800'000 cycles (0÷110 bar).
- Tested according standards: ISO 2941 / ISO 3724 / ISO 3968.

## D Mitteldrückeleitungsfilter (max. 110 bar)

### TECHNISCHE DATEN:

- Kopf: eloxiertem Aluminium-Druckguss.
- Filtergehäuse: eloxiertem Aluminium-Druckguss.
- By-pass Ventil: Differenzdrückeröffnung 6 bar.
- Standard verfügbaren Anschlüssen: 1/2" bspp. Weitere Gewinde auf Anfrage erhältlich
- Standard verfügbaren Filterelemente: 3-5-10-25 Mikron abs. Mikrofaser / 10-25 Mikron nom. Papier. Weitere Materialien auf Anfrage erhältlich.
- Dichtungen: Buna-N Standard. Viton auf Wunsch.
- Betriebstemperatur: von -30°C bis +90°C (+110°C Viton).
- Max. Durchfluß: 90 l/min.
- Betriebsdruck: 110 bar. Berstdruck: 300 bar.
- Patronenkollapsdrücke: 21 bar.
- Ermüdungswiderstand: > 800'000 Zyklen (0÷110 bar).
- Test nach Normen: ISO 2941 / ISO 3724 / ISO 3968.

## FR Filtres en ligne a moyenne pression (max. 110 bar)

### CARACTERISTIQUES TECHNIQUES:

- Tête: fusion d'aluminium anodisé.
- Corp du filtre: fusion d'aluminium anodisé.
- Clapet by-pass: Ouverture différentiel 6 bar.
- Connexions standard disponibles: 1/2" bspp. Filetages spéciaux sur demande.
- Eléments filtrants standard disponibles: 3-5-10-25 Micron abs. en microfibre / 10-25 Micron nom. papier. Autres filtrations sur demande.
- Joints: Buna-N standard. Viton sur demande.
- Temperature de travaille: de -30°C à +90°C (+110°C Viton).
- Débits max.: 90 l/min.
- Pression de service: 110 bar. Pression d'éclatement: 300 bar.
- Pression d'écrasement élément filtrant: 21 bar.
- Résistance à fatigue: > 800'000 cycles (0÷110 bar).
- Test selon standards: ISO 2941 / ISO 3724 / ISO 3968.

## ES Filtros en linea a media presión (max. 110 bar)

### CARACTERÍSTICAS TÉCNICAS:

- Cabeza filtro: fundición de aluminio anodizado.
- Cuerpo filtro: fundición de aluminio anodizado.
- Válvula de by-pass: Apertura diferencial 6 bar.
- Conexiones disponibles estándar: 1/2" bspp. Rosca especial bajo pedido.
- Elemento filtrante disp. estándar: 3-5-10-25 Micron abs. en microfibra / 10-25 Micron nom. papel. Otras filtraciones bajo pedido.
- Juntas: estándar Buna-N. Bajo pedido Viton.
- Temperatura de trabajo: de -30°C a +90°C (+110°C Viton).
- Max. caudal: 90 l/min
- Presión de trabajo: 110 bar. Presión de rotura: 300 bar
- Presión de colapso del cartucho: 21 bar.
- Resistencia a la fatiga: > 800'000 ciclos (0÷110 bar).
- Prueba realizada según normativa: ISO 2941 / ISO 3724 / ISO 3968.

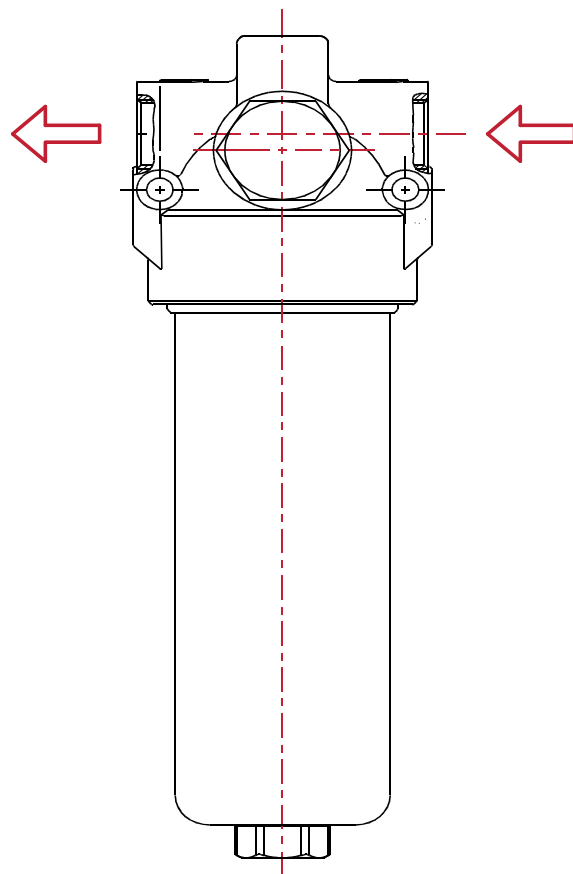



# PF11-12

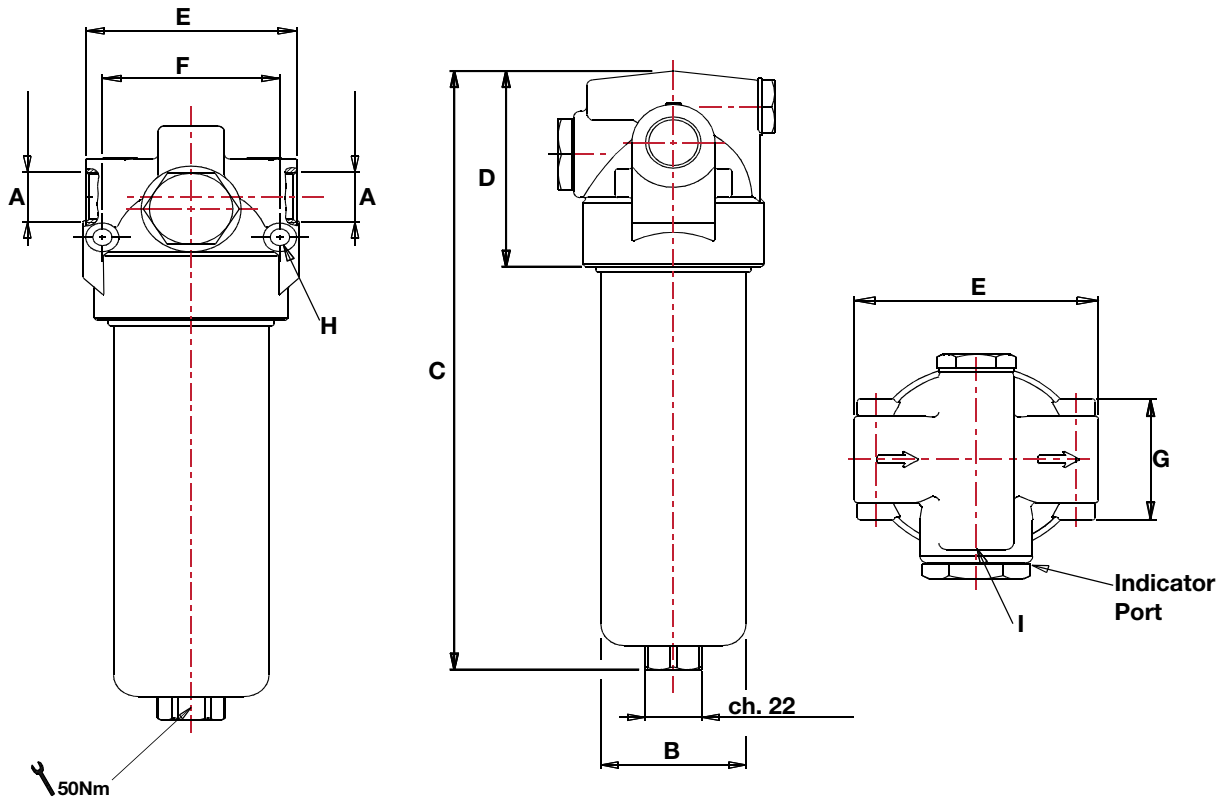

## FILTRO COMPLETO MEDIA PRESSIONE 110 bar - MEDIUM PRESSURE COMPLETE FILTER 110 bar

Mod.	DIMENSIONI mm - DIMENSIONS mm									PESO - WEIGHT
	A	B	C	D	E	F	G	H	I	Kg.
PF11	1/2" bspp	56	158	80	76	64	45	Ø 7	M20x1,5	1,00
PF12	1/2" bspp	56	248	80	76	64	45	Ø 7	M20x1,5	1,30

# COME ORDINARE UN FILTRO COMPLETO:

HOW TO ORDER A COMPLETE FILTER:

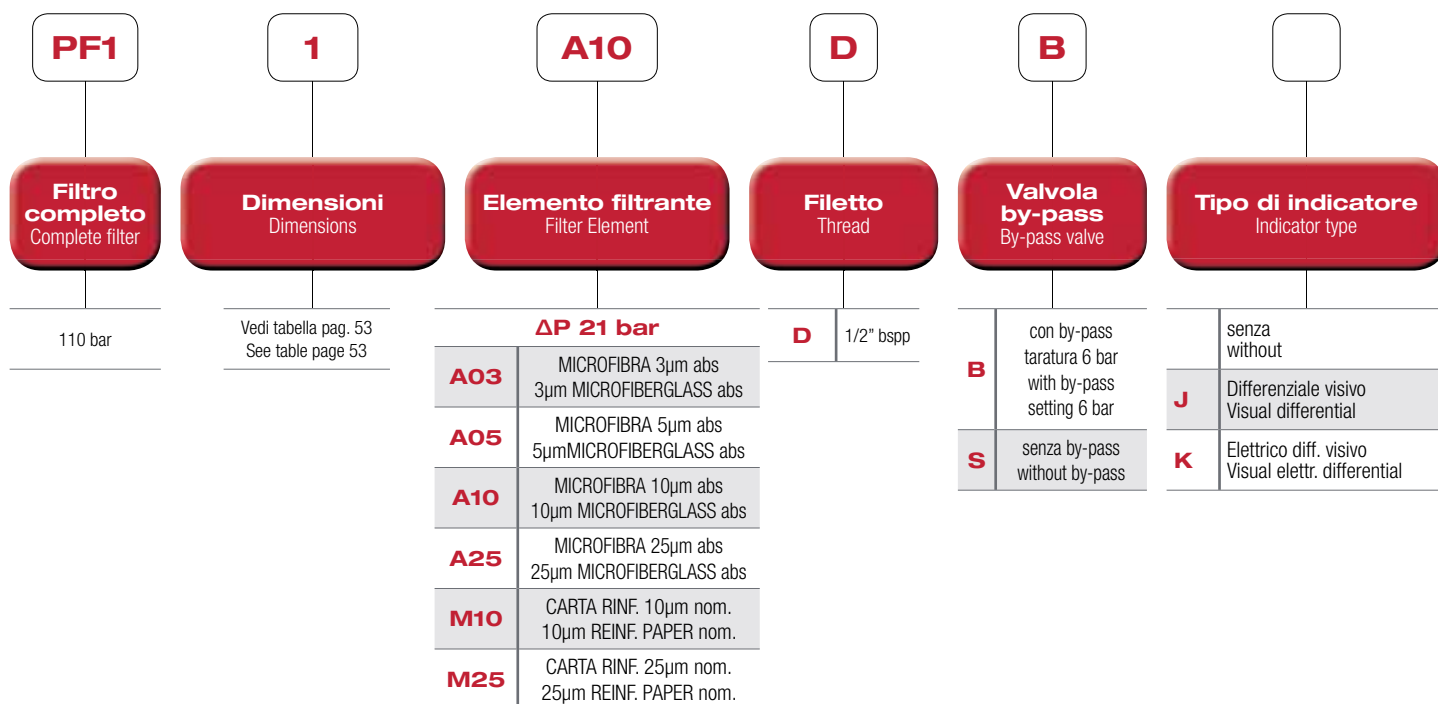

# COME ORDINARE LA CARTUCCIA DI RICAMBIO:

HOW TO ORDER THE REPLACEMENT ELEMENT:

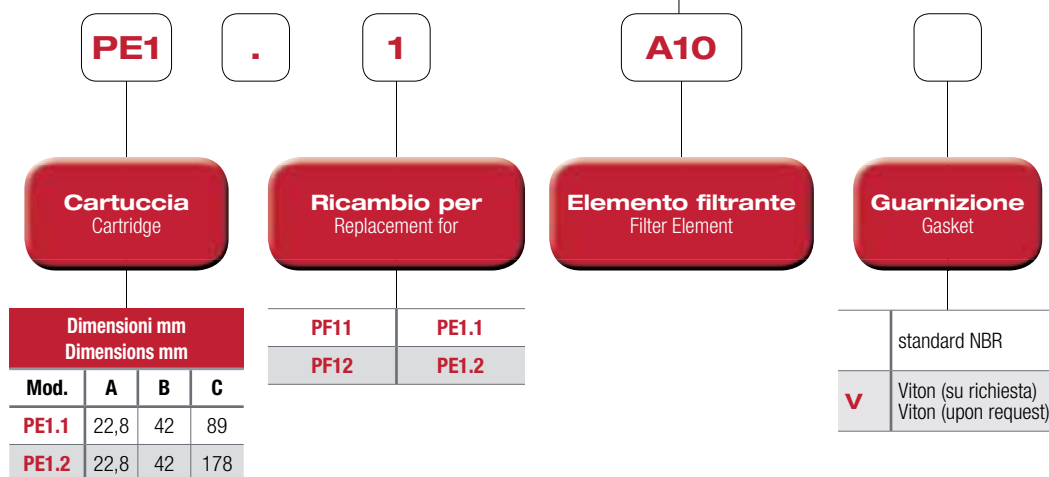
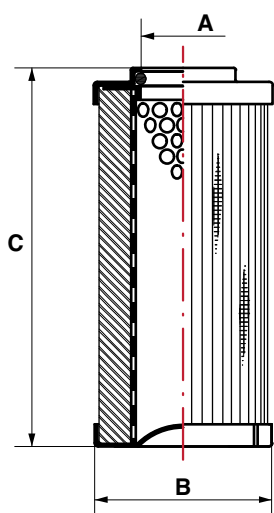

**Portate PF1\*\***

Portate in l/min. rievate con  
Dp=2 bar

**PF1 flow rates\*\***

Flow rate in l/min. measured with  
Dp=2 bar

**Filtredurchfluß PF1\*\***

Filterdurchfluß in l/min. gemessen  
bei Dp=2 bar

**Débits PF1\*\***

Débits en l/min. mesurés avec  
Dp=2 bar

**Caudales PF1\*\***

Débits en l/min. mesurés avec  
Dp=2 bar

ELEMENTO FILTRANTE FILTERING ELEMENT		MICROFIBRA / FIBERGLASS				CARTA / PAPER	
Mod.	FILETTO THREAD BSPP	A03 3 MICRON ABS	A05 5 MICRON ABS	A10 10 MICRON ABS	A25 25 MICRON ABS	M10 10 MICRON NOM	M25 25 MICRON NOM
PF11	1/2"	20	35	45	60	50	65
PF12	1/2"	35	55	70	85	75	90

\*\* Portate rilevate con olio avente viscosità cinematica di 30 cSt e densità 0.86 kg/dm<sup>3</sup>

\*\* Flow rates measured with oil with 30 cSt kinematic viscosity and 0.86 kg/dm<sup>3</sup>

• Compatibilità con fluidi: oli minerali (HH-HL-HM-HR-HV-HG) e fluidi sintetici (HS-HFDR-HFDU-HFDS).

• Fluid compatibility: mineral oil (HH-HL-HM-HR-HV-HG) and synthetic fluids (HS-HFDR-HFDU-HFDS).

**Capacità d'accumulo  
Cartucce PE1  
(ISO MTD)**

Δp=5 bar

**PE1 element  
dirt holding capacity  
(ISO MTD)**

Δp=5 bar

**Element PE1  
Schmutz-  
sammlungskapazität  
(ISO MTD)**

Δp=5 bar

**Capacité  
d'accumulation  
cartouches PE1  
(ISO MTD)**

Δp=5 bar

**Capacidad de  
retención cartuchos  
PE1 (ISO MTD)**

Δp=5 bar

ELEMENTO FILTRANTE FILTERING ELEMENT			MICROFIBRA / FIBERGLASS				CARTA / PAPER	
Mod.	C mm	SUPERFICIE FILTRANTE FILTERING SURFACE cm <sup>2</sup>	A03 3 MICRON ABS gr	A05 5 MICRON ABS gr	A10 10 MICRON ABS gr	A25 25 MICRON ABS gr	M10 10 MICRON NOM gr	M25 25 MICRON NOM gr
HP11	89	300	1,5	2,2	2,50	3,70	2,00	3,2
HP12	178	700	3,70	4,90	5,20	7,80	4,20	6,70

## INDICATORI INTASAMENTO

CLOGGING INDICATORS - VERSCHMUTZUNGSANZEIGEN - INDICATEURS DE COLMAGE -

INDICADORES DE SUCIEDAD

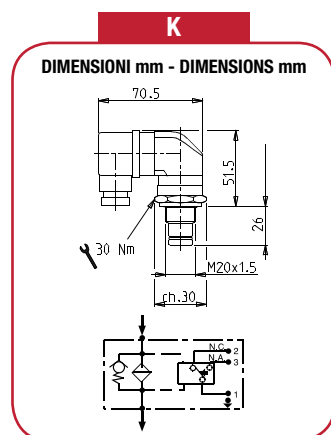
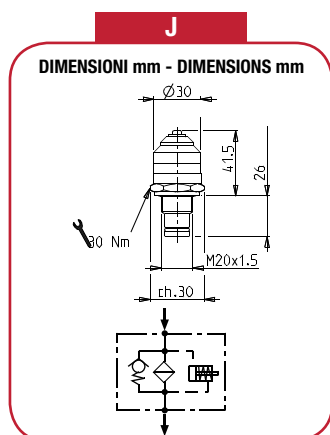

SERIE SERIES	TARATURA SETTING	TIPO TYPE
J	8 bar (no by-pass) 5 bar (by-pass)	Differenziale visivo Visual differential Optisch Differenzdruckanzeige Differential visuel Visual Diferencial
K	8 bar (no by-pass) 5 bar (by-pass)	Elettrico differenziale visivo IP65 - 250Vac Visual electrical differential IP65 - 250Vac Optisch El. Differenzdruckanzeige IP65 - 250Vac Differential visuel el. IP65 - 250Vac Visual Diferencial el. IP65 - 250Vac

# SERIE PF2 (max. 280 bar)

## IT Filtri in linea a media pressione (max. 280 bar)

### CARATTERISTICHE TECNICHE:

- Testata: ghisa sferoidale.
- Corpo filtro: acciaio estruso.
- Valvola by-pass: Apertura differenziale 6 bar.
- Attacchi disponibili standard: 1/2"-3/4"-1" bspp. Filettature speciali su richiesta.
- Elementi filtranti disponibili standard: 3-5-10-25 Micron abs. microfibra. Altre filtrazioni su richiesta.
- Guarnizioni: standard Buna-N. Su richiesta Viton.
- Temperatura esercizio: da -30°C a +90°C (+110°C Viton).
- Portata massima: 170 l/min.
- Pressione di esercizio: 280 bar. Pressione di scoppio: 560 bar.
- Pressione di collasso cartuccia: 21 bar o 210 bar.
- Resistenza a fatica: 1'000'000 cicli (0÷280 bar).
- Test eseguiti secondo normative: ISO 2941 / ISO 3724 / ISO 3968.

## GB Medium pressure in-line filters (max. 280 bar)

### TECHNICAL FEATURES:

- Head: s.g. cast iron.
- Filter body: forged steel.
- By-pass valve: Differential opening 6 bar.
- Standard available threads: 1/2"-3/4"-1" bspp. Other threads upon request.
- Standard available filter elements: 3-5-10-25 Micron abs. microfiber. Other filter elements upon request.
- Seals: Buna-N standard. Viton upon request.
- Operating temperature: -30°C a +90°C (+110°C Viton).
- Maximum flow rate: 170 l/min.
- Operating pressure: 280 bar. Burst pressure: 560 bar.
- Element collapse pressure: 21 bar or 210 bar.
- Fatigue resistance: 1'000'000 cycles (0÷280 bar).
- Tested according standards: ISO 2941 / ISO 3724 / ISO 3968.

## D Mitteldrückeitungsfiler (max. 280 bar)

### TECHNISCHE DATEN:

- Kopf: Sphäroguss.
- Filtergehäuse: Kaltfließstahl.
- By-pass Ventil: Differenzdrückeröffnung 6 bar.
- Standard verfügbaren Anschlu en: 1/2"-3/4"-1" bspp. Weitere Gewinde auf Anfr. erhaltlich.
- Standard verfügbaren Filterelemente: 3-5-10-25 Mikron abs. Mikrofaser. Weitere Materialien auf Anfrage erhaltlich.
- Dichtungen: Buna-N Standard. Viton auf Wunsch.
- Betriebstemperatur: von -30°C a +90°C (+110°C Viton).
- Max. Durchflu : 170 l/min.
- Betriebsdr ck: 280 bar. Berstdr ck: 560 bar.
- Patronekollapsdr cke: 21 bar oder 210 bar.
- Ermüdungswiderstand: 1'000'000 Zyklen (0÷280 bar).
- Test nach Normen: ISO 2941 / ISO 3724 / ISO 3968.

## FR Filtres en ligne a moyenne pression (max. 280 bar)

### CARACTERISTIQUES TECHNIQUES:

- T te: fonte sph roidal.
- Corp du filtre: acier extrud .
- Clapet by-pass: Ouverture diff rentiel 6 bar.
- Connexions standard disponibles: 1/2"-3/4"-1" bspp. Filetages sp ciaux sur demande.
- El ments filtrants standard disponibles: 3-5-10-25 Micron abs. en microfibre. Autres filtrations sur demande.
- Joints: Buna-N standard. Viton sur demande.
- Temperature de travaille: de -30°C a +90°C (+110°C Viton).
- D bits max.: 170 l/min.
- Pression de service: 280 bar. Pression d' clatement: 560 bar.
- Pression d' crasement el ment filtrant: 21 bar ou 210 bar.
- R sistance   fatigue: 1'000'000 cycles (0÷280 bar).
- Test selon standards: ISO 2941 / ISO 3724 / ISO 3968.

## ES Filtros en linea a media presi n (max. 280 bar)

### CARACTERÍSTICAS TÉCNICAS:

- Cabeza filtro: fundici n esferooidal.
- Cuerpo filtro: acero extrusionado.
- Vlvula de by-pass: Apertura diferencial 6 bar.
- Conexiones disponibles estndar: 1/2"-3/4"-1" bspp. Rosca especial bajo pedido.
- Elemento filtrante disp. estndar: 3-5-10-25 Micron abs. en microfibra. Otras filtraciones bajo pedido.
- Juntas: estndar Buna-N. Bajo pedido Viton.
- Temperatura de trabajo: de -30°C a +90°C (+110°C Viton).
- Max. caudal: 170 l/min
- Presi n de trabajo: 280 bar. Presi n de rotura: 560 bar
- Presi n de colapso del cartucho: 21 bar o 210 bar.
- Resistencia a la fatiga: 1'000'000 ciclos (0÷280 bar).
- Prueba realizada seg n normativa: ISO 2941 / ISO 3724 / ISO 3968.

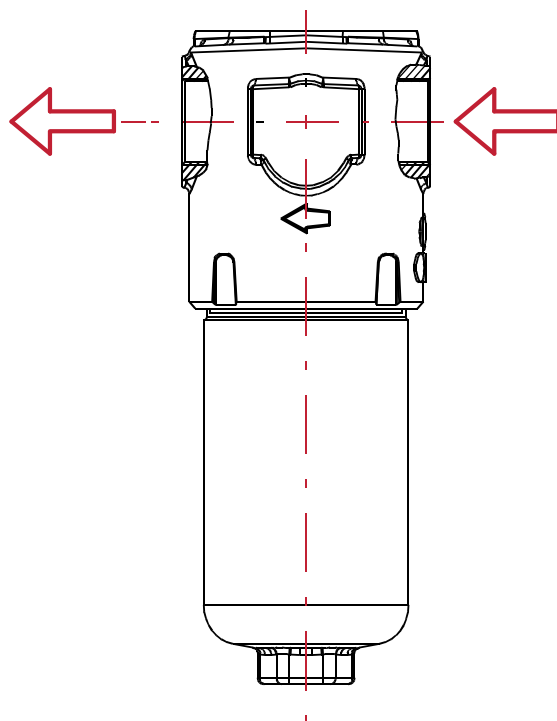



# PF21-22-23

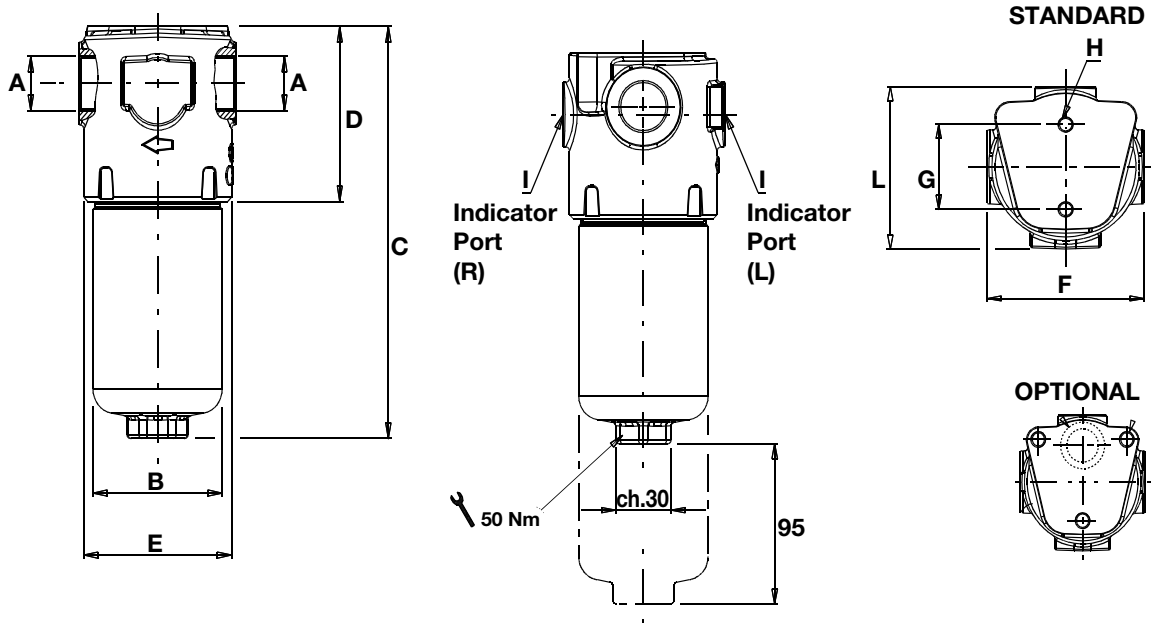

## FILTRO COMPLETO ALTA PRESSIONE 280 bar - HIGH PRESSURE COMPLETE FILTER 280 bar

Mod.	DIMENSIONI mm - DIMENSIONS mm										PESO - WEIGHT
	A	B	C	D	E	F	G	H	I	L	kg.
PF21	1/2" bspp 3/4" bspp	70	173	85	80	85	46	M8	1/2" bspp	88	3,8
PF22		70	200	85	80	85	46	M8	1/2" bspp	88	4,2
PF23		70	295	85	80	85	46	M8	1/2" bspp	88	5,7

# PF24-25

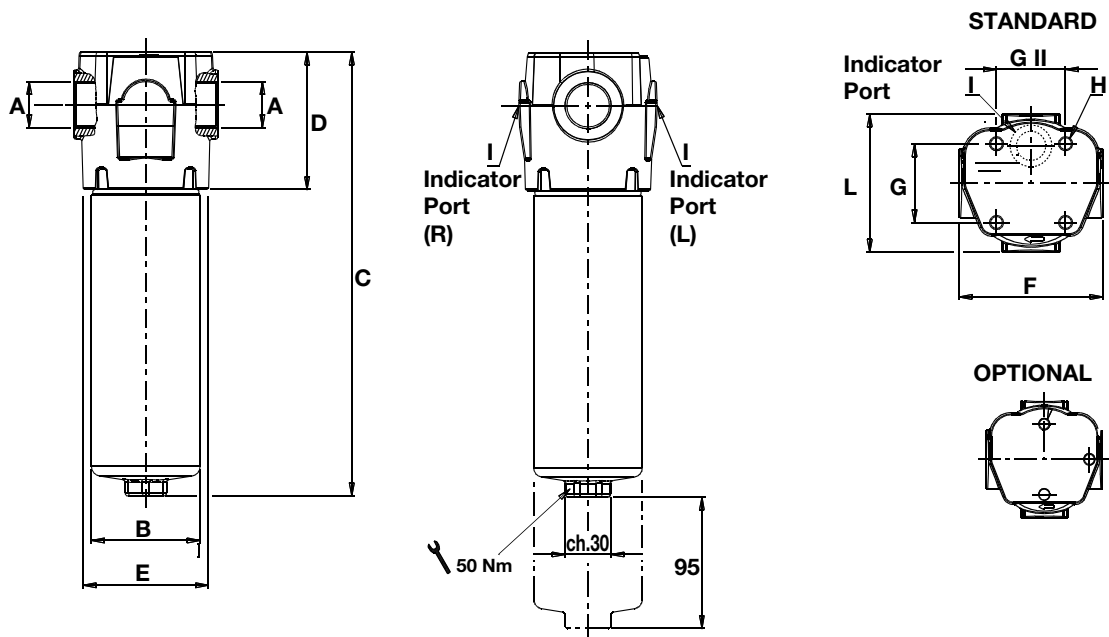

## FILTRO COMPLETO ALTA PRESSIONE 280 bar - HIGH PRESSURE COMPLETE FILTER 280 bar

Mod.	DIMENSIONI mm - DIMENSIONS mm										PESO - WEIGHT	
	A	B	C	D	E	F	G	G II	H	I	L	kg.
PF24	3/4" bspp	79	214	100	91	105	57	50	M10	1/2" bspp	100	6,0
PF25	1" bspp	79	322	100	91	105	57	50	M10	1/2" bspp	100	7,8

# COME ORDINARE UN FILTRO COMPLETO:

HOW TO ORDER A COMPLETE FILTER:

<b>PF2</b>	<b>1</b>	<b>A10</b>	<b>E</b>	<b>B</b>	
<b>Filtro completo</b> Complete filter	<b>Dimensioni</b> Dimensions	<b>Elemento filtrante</b> Filter Element	<b>Filetto</b> Thread	<b>Valvola by-pass</b> By-pass valve	<b>Tipo di indicatore*</b> Indicator type*
280 bar	Vedi tabella pag. 57 See table page 57	<b>ΔP 21 bar</b>	<b>D</b> 1/2" bspp (PF21-22-23)	<b>B</b> con by-pass taratura 6 bar with by-pass setting 6 bar	senza without
		<b>A03</b> MICROFIBRA 3µm abs 3µm MICROFIBERGLASS abs	<b>E</b> 3/4" bspp (PF21-22-23-24-25)	<b>S</b> senza by-pass without by-pass	<b>T</b> Differenziale visivo Visual differential
		<b>A05</b> MICROFIBRA 5µm abs 5µm MICROFIBERGLASS abs	<b>F</b> 1" bspp (PF24-25)		<b>U</b> Elettrico diff. visivo Visual electr. differential
		<b>A10</b> MICROFIBRA 10µm abs 10µm MICROFIBERGLASS abs			
		<b>A25</b> MICROFIBRA 25µm abs 25µm MICROFIBERGLASS abs			
		<b>ΔP 210 bar</b>			
		<b>H03</b> MICROFIBRA 3µm abs 3µm MICROFIBERGLASS abs			
		<b>H05</b> MICROFIBRA 5µm abs 5µm MICROFIBERGLASS abs			
		<b>H10</b> MICROFIBRA 10µm abs 10µm MICROFIBERGLASS abs			
		<b>H25</b> MICROFIBRA 25µm abs 25µm MICROFIBERGLASS abs			

\* Precisare posizione (standard a destra)  
\* Precise position (standard right)

# COME ORDINARE LA CARTUCCIA DI RICAMBIO:

HOW TO ORDER THE REPLACEMENT ELEMENT:

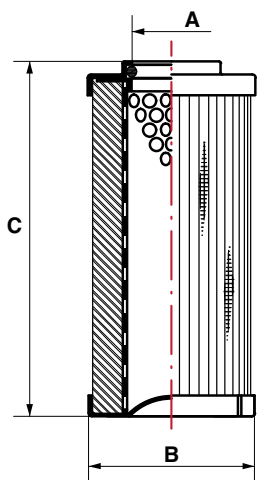

<b>PE2</b>	.	<b>1</b>	<b>A10</b>	
<b>Cartuccia</b> Cartridge		<b>Ricambio per</b> Replacement for	<b>Elemento filtrante</b> Filter Element	<b>Guarnizione</b> Gasket
<b>DIMENSIONI mm</b> <b>DIMENSIONS mm</b>				
<b>Mod.</b>	<b>A</b>	<b>B</b>	<b>C</b>	
<b>PE2.1</b>	25,5	47	86	
<b>PE2.2</b>	25,5	47	115	
<b>PE2.3</b>	25,5	47	208	
<b>PE2.4</b>	27,5	54	122	
<b>PE2.5</b>	27,5	54	229	
		<b>PF21</b>	<b>PE2.1</b>	
		<b>PF22</b>	<b>PE2.2</b>	
		<b>PF23</b>	<b>PE2.3</b>	
		<b>PF24</b>	<b>PE2.4</b>	
		<b>PF25</b>	<b>PE2.5</b>	
				standard NBR
				<b>V</b> Viton (su richiesta) Viton (upon request)

**Portate PF2\*\***

Portate in l/min. rievate con  
Dp=0,75 bar

**PF2 flow rates\*\***

Flow rate in l/min. measured with  
Dp=0,75 bar

**Filtredurchfluß PF2\*\***

Filterdurchfluß in l/min. gemessen  
bei Dp=0,75 bar

**Débits PF2\*\***

Débits en l/min. mesurés avec  
Dp=0,75 bar

**Caudales PF2\*\***

Débits en l/min. mesurés avec  
Dp=0,75 bar

ELEMENTO FILTRANTE FILTERING ELEMENT		MICROFIBRA / FIBERGLASS			
Mod.	FILETTO - THREAD BSPP	A03 3 MICRON ABS	A05 5 MICRON ABS	A10 10 MICRON ABS	A25 25 MICRON ABS
PF21	1/2"	25	30	35	45
	3/4"	25	30	35	45
PF22	1/2"	35	40	50	60
	3/4"	35	40	50	60
PF23	1/2"	60	65	75	85
	3/4"	65	70	80	95
PF24	3/4"	60	65	80	100
	1"	60	70	85	105
PF25	3/4"	105	120	135	155
	1"	110	125	145	170

\*\* Portate rievate con olio avente viscosità cinematica di 30 cSt e densità 0.86 kg/dm<sup>3</sup>

\*\* Flow rates measured with oil with 30 cSt kinematic viscosity and 0.86 kg/dm<sup>3</sup>

• Compatibilità con fluidi: oli minerali (HH-HL-HM-HR-HV-HG) e fluidi sintetici (HS-HFDR-HFDU-HFDS).

• Fluid compatibility: mineral oil (HH-HL-HM-HR-HV-HG) and synthetic fluids (HS-HFDR-HFDU-HFDS).

**Capacità d'accumulo  
Cartucce PE2  
(ISO MTD)**  
Δp=5 bar

**PE2 element dirt  
holding capacity  
(ISO MTD)**  
Δp=5 bar

**Element PE2  
Schmutzan-  
sammlungskapazität  
(ISO MTD)**  
Δp=5 bar

**Capacità  
d'accumulation  
cartouches PE2  
(ISO MTD)**  
Δp=5 bar

**Capacidad de  
retención cartuchos  
PE2 (ISO MTD)**  
Δp=5 bar

ELEMENTO FILTRANTE FILTERING ELEMENT			MICROFIBRA / FIBERGLASS			
Mod.	C mm	SUPERFICIE FILTRANTE FILTERING SURFACE cm <sup>2</sup>	A03 3 MICRON ABS gr	A05 5 MICRON ABS gr	A10 10 MICRON ABS gr	A25 25 MICRON ABS gr
PE2.1	85	380	2,10	2,70	3,00	4,40
PE2.2	115	500	3,00	3,90	4,40	6,40
PE2.3	208	950	5,30	6,70	7,50	11,00
PE2.4	122	900	5,10	6,50	7,30	10,50
PE2.5	229	1800	10,10	13,00	14,50	21,00

**INDICATORI INTASAMENTO** CLOGGING INDICATORS - VERSCHMUTZUNGSANZEIGEN - INDICATEURS DE COLMAGE - INDICADORES DE SUCIEDAD

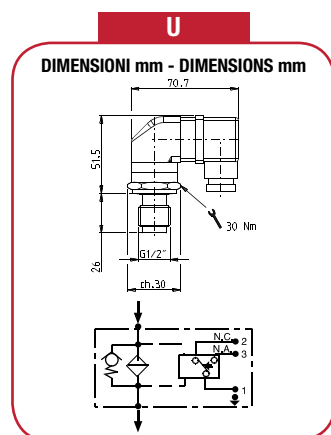
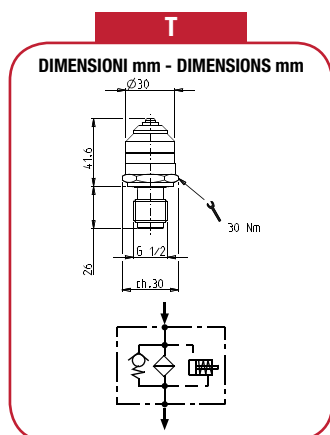

SERIE SERIES	TARATURA SETTING	TIPO TYPE
T	8 bar (no by-pass) 5 bar (by-pass)	Differenziale visivo Visual differential Optisch Differenzdruckanzeige Differential visuel Visual Diferencial
U	8 bar (no by-pass) 5 bar (by-pass)	Elettrico differenziale visivo IP65 - 250Vac Visual electrical differential IP65 - 250Vac Optisch El. Differenzdruckanzeige IP65 - 250Vac Differential visuel el. IP65 - 250Vac Visual Diferencial el. IP65 - 250Vac

# SERIE PF3 (max. 350 bar)

## IT Filtri in linea alta pressione (max. 350 bar) tipo "last chance" - Flusso bidirezionale

### CARATTERISTICHE TECNICHE:

- Corpo filtro: alluminio alta resistenza.
- Cartuccia interna: in bronzo sinterizzato.
- Attacchi disponibili standard: 1/4"-3/8"-1/2"-3/4" bsp. . Filettature speciali su richiesta.
- Elementi filtranti disponibili standard: 10-25-40-60 Micron nom.
- Guarnizioni: standard Buna-N. Su richiesta Viton.
- Temperatura esercizio: da -30°C a +90°C (+110°C Viton).
- Portata massima: 115 l/min.
- Pressione di esercizio: 350 bar. Pressione di scoppio: 520 bar.
- Pressione di collasso cartuccia: 80 bar.
- Resistenza a fatica: 1'000'000 cicli (0÷350 bar).
- Test eseguiti secondo normative: ISO 2941 / ISO 3724 / ISO 3968.

## GB High pressure in-line filters (max. 350 bar) "last chance" type - Bidirectional flow

### TECHNICAL FEATURES:

- Filter body: aluminium high-resistance.
- Inner element: sintered bronze.
- Standard available threads: 1/4"-3/8"-1/2"-3/4" bsp. Other threads upon request.
- Standard available filter elements: 10-25-40-60 Micron nom.
- Seals: Buna-N standard. Viton upon request.
- Operating temperature: -30°C a +90°C (+110°C Viton).
- Maximum flow rate: 115 l/min.
- Operating pressure: 350 bar. Burst pressure: 520 bar.
- Element collapse pressure: 80 bar.
- Fatigue resistance: 1'000'000 cycles (0÷350 bar).
- Tested according standards: ISO 2941 / ISO 3724 / ISO 3968.

## D Hochdruckleitungsfilter (max. 350 bar) typ "last chance" - Bidirektional fluB

### TECHNISCHE DATEN:

- Filtergehäuse: hochfestem Aluminium.
- Innere Patrone: Sinterbronze.
- Standard verfügbaren Anschlüssen: 1/4"-3/8"-1/2"-3/4" bsp. Weitere Gewinde auf Anfrage erhältlich.
- Standard verfügbaren Filterelemente: 10-25-40-60 Mikron nom.
- Dichtungen: Buna-N Standard. Viton auf Wunsch.
- Betriebstemperatur: von -30°C a +90°C (+110°C Viton).
- Max. DurchfluB: 115 l/min.
- Betriebsdruck: 350 bar. Berstdruck: 520 bar.
- Patronenkollapsdrücke: 80 bar.
- Ermüdungswiderstand: 1'000'000 Ziklen (0÷350 bar).
- Test nach Normen: ISO 2941 / ISO 3724 / ISO 3968.

## FR Filtres en ligne a haute pression (max. 350 bar) type „last chance“ - Flux bidirectionnel

### CARACTERISTIQUES TECHNIQUES:

- Corp du filtre: aluminium haute résistance.
- Cartouche intérieure: bronze fritté.
- Connexions standard disponibles: 1/4"-3/8"-1/2"-3/4" bsp. Filetages spéciaux sur demande.
- Eléments filtrants standard disponibles: 10-25-40-60 Micron nom.
- Joints: Buna-N standard. Viton sur demande.
- Temperature de travaille: de -30°C a +90°C (+110°C Viton).
- Débit max.: 115 l/min.
- Pression de service: 350 bar. Pression d'éclatement: 520 bar.
- Pression d'écrasement élément filtrant: 80 bar.
- Résistance á fatigue: 1'000'000 cycles (0÷350 bar).
- Test selon standards: ISO 2941 / ISO 3724 / ISO 3968.

## ES Filtros en linea a alta presión (max. 350 bar) tipo „last chance“ - Flujo bidireccional

### CARACTERÍSTICAS TÉCNICAS:

- Cuerpo filtro: aluminio alta resistencia.
- Cartucho interno: bronce sinterizado.
- Conexiones disponibles estándar: 1/4"-3/8"-1/2"-3/4" bsp. Rosca especial bajo pedido.
- Elemento filtrante disp. estándar: 10-25-40-60 Micron nom.
- Juntas: estándar Buna-N. Bajo pedido Viton.
- Temperatura de trabajo: de -30°C a +90°C (+110°C Viton).
- Max. caudal: 115 l/min
- Presión de trabajo: 350 bar. Presión de rotura: 520 bar
- Presión de colapso del cartucho: 80 bar.
- Resistencia a la fatiga: 1'000'000 ciclos (0÷350 bar).
- Prueba realizada según normativa: ISO 2941 / ISO 3724 / ISO 3968.

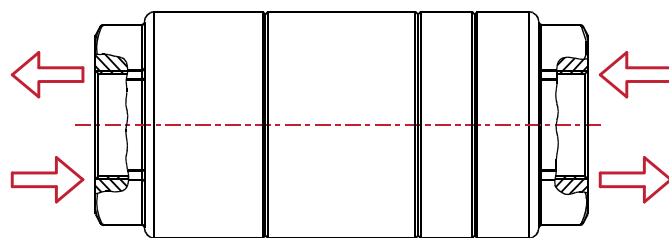



# PF31-32

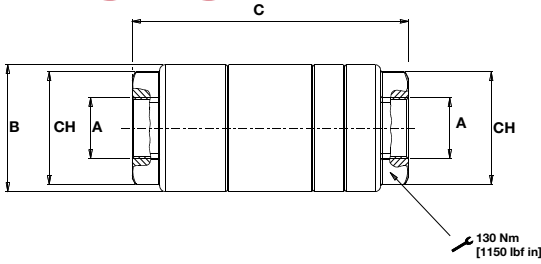

## FILTRO COMPLETO ALTA PRESSIONE 350 bar HIGH PRESSURE COMPLETE FILTER 350 bar

Mod.	DIMENSIONI mm - DIMENSIONS mm				PESO - WEIGHT
	A	B	C	CH	kg.
PF31	1/4" bspp 3/8" bspp 1/2" bspp	44	100	35	0,3
PF32	1/2" bspp 3/4" bspp	54	140	41	0,6

## COME ORDINARE UN FILTRO COMPLETO:

HOW TO ORDER A COMPLETE FILTER:

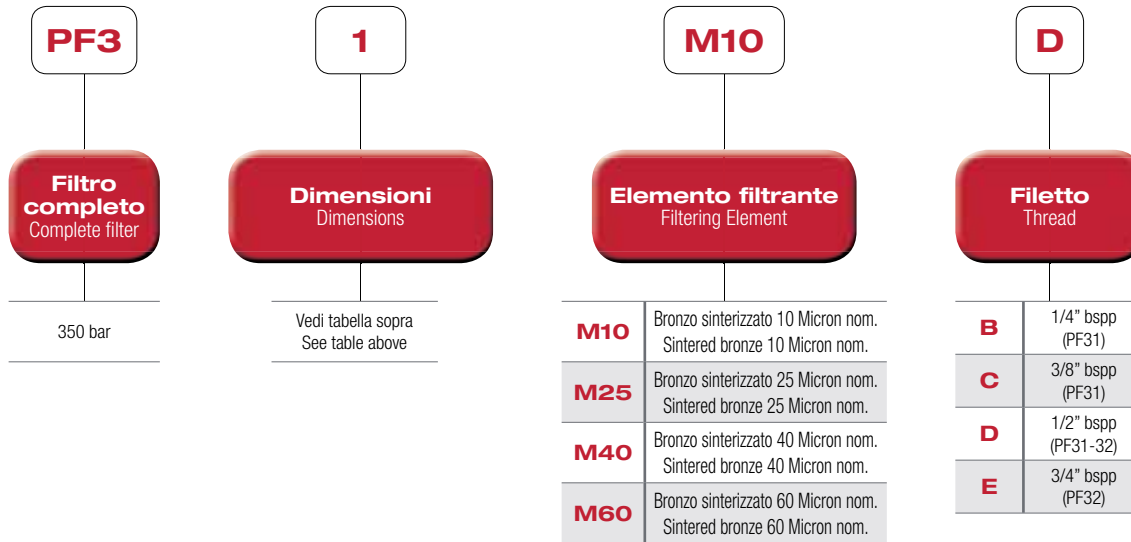

## COME ORDINARE LA CARTUCCIA DI RICAMBIO:

HOW TO ORDER THE REPLACEMENT ELEMENT:

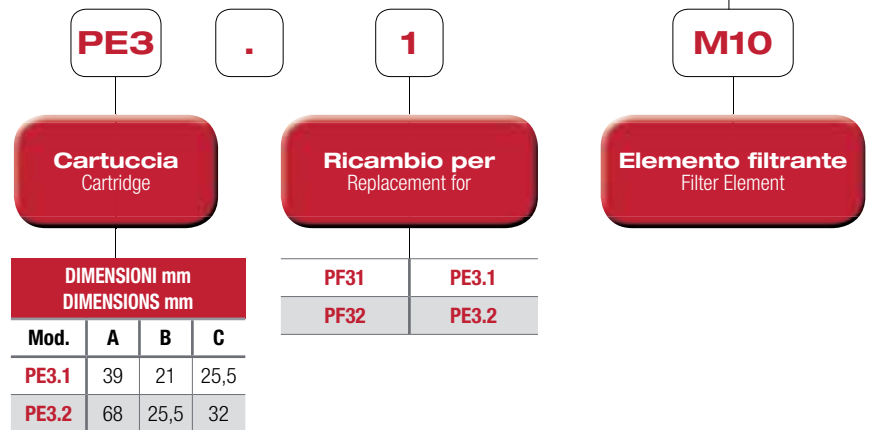
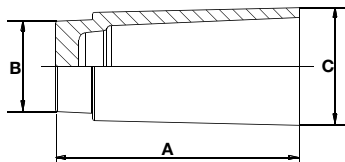

### Portate PF3\*\*

Portate in l/min. rilevate con  
Dp=2 bar

### PF3 flow rates\*\*

Flow rate in l/min. measured with  
Dp=2 bar

### Filterdurchfluß PF3\*\*

Filterdurchfluß in l/min. gemessen  
bei Dp=2 bar

### Débites PF3\*\*

Débites en l/min. mesurés avec  
Dp=2 bar

### caudales PF3\*\*

Débites en l/min. mesurés avec  
Dp=2 bar

Mod.	FILETTO - THREAD BSPP	BRONZO SINTERIZZATO / SINTERED BRONZE			
		M10 10 MICRON NOM	M25 25 MICRON NOM	M40 40 MICRON NOM	M60 60 MICRON NOM
PF31	1/4"	5	15	25	30
	3/8"	7	25	35	45
	1/2"	10	30	40	65
PF32	1/2"	15	35	55	80
	3/4"	20	40	70	115

\*\* Portate rilevate con olio avente viscosità cinematica di 30 cSt e densità 0.86 kg/dm<sup>3</sup>

\*\* Flow rates measured with oil with 30 cSt kinematic viscosity and 0.86 kg/dm<sup>3</sup>

# SERIE PF4 (max. 420 bar)

## IT Filtri in linea alta pressione (max. 420 bar)

### CARATTERISTICHE TECNICHE:

- Corpo filtro: ghisa sferoidale. Corpo filtro: acciaio estruso.
- Valvola by-pass: Apertura differenziale 6 bar.
- Attacchi disponibili standard: 1/2"-3/4"-1"-1 1/4"-1 1/2" bspp. Filettature spec. su rich.
- Elementi filtranti disponibili standard: 3-5-10-25 Micron abs. Microfibra. Altre filtrazioni su rich.
- Guarnizioni: standard Buna-N. Su richiesta Viton.
- Temperatura esercizio: da -30°C a +90°C (+110°C Viton).
- Portata massima: 450 l/min.
- Pressione di esercizio: 420 bar. Pressione di scoppio: 1260 bar.
- Pressione di collasso cartuccia: 21 bar o 210 bar.
- Resistenza a fatica: 1'000'000 cicli (0÷420 bar).
- Test eseguiti secondo normative: ISO 2941 / ISO 3724 / ISO 3968.

## GB High pressure in-line filters (max. 420 bar)

### TECHNICAL FEATURES:

- Head: s.g. cast iron. Filter body: forged steel.
- By-pass valve: Differential opening 6 bar.
- Standard available threads: 1/2"-3/4"-1"-1 1/4"-1 1/2" bspp. Other threads upon request.
- Standard available filter elements: 3-5-10-25 Micron abs. microfiber. Other filter elements upon request.
- Seals: Buna-N standard. Viton upon request.
- Operating temperature: -30°C a +90°C (+110°C Viton).
- Maximum flow rate: 450 l/min.
- Operating pressure: 420 bar. Burst pressure: 1260 bar.
- Element collapse pressure: 21 bar or 210 bar.
- Fatigue resistance: 1'000'000 cycles (0÷420 bar).
- Tested according standards: ISO 2941 / ISO 3724 / ISO 3968.

## D Hochdrückleitungsfilter (max. 420 bar)

### TECHNISCHE DATEN:

- Kopf: Sphäroguss. Filtergehäuse: Kaltfließpresstahl.
- By-pass Ventil: Differenzdrückeröffnung 6 bar.
- Standard verfügbaren Anschlüssen: 1/2"-3/4"-1"-1 1/4"-1 1/2" bspp. Weitere Gewinde auf Anfrage erhältlich.
- Standard verfügbaren Filterelemente: 3-5-10-25 Mikron abs. Mikrofaser. Weitere Materialien auf Anfrage erhältlich.
- Dichtungen: Buna-N Standard. Viton auf Wunsch.
- Betriebstemperatur: von -30°C a +90°C (+110°C Viton).
- Max. Durchfluß: 450 l/min.
- Betriebsdruck: 420 bar. Berstdruck: 1260 bar.
- Patronekollapsdrücke: 21 bar oder 210 bar.
- Ermüdungswiderstand: 1'000'000 Zyklen (0÷420 bar).
- Test nach Normen: ISO 2941 / ISO 3724 / ISO 3968.

## FR Filtres en ligne a haute pression (max. 420 bar)

### CARACTERISTIQUES TECHNIQUES:

- Tête: fonte sphéroidal. Corp du filtre: acier extrudé.
- Clapet by-pass: Ouverture différentiel 6 bar.
- Connexions standard disponibles: 1/2"-3/4"-1"-1 1/4"-1 1/2" bspp. Filetages spéciaux sur demande.
- Eléments filtrants standard disponibles: 3-5-10-25 Micron abs. en microfibre. Autres filtrations sur demande.
- Joints: Buna-N standard. Viton sur demande.
- Temperature de travaille: de -30°C a +90°C (+110°C Viton).
- Débits max.: 450 l/min.
- Pression de service: 420 bar. Pression d'éclatement: 1260 bar.
- Pression d'écrasement élément filtrant: 21 bar ou 210 bar.
- Résistance à fatigue: 1'000'000 cycles (0÷420 bar).
- Test selon standards: ISO 2941 / ISO 3724 / ISO 3968.

## ES Filtros en linea a alta presión (max. 420 bar)

### CARACTERÍSTICAS TÉCNICAS:

- Cabeza filtro: fundición esferoidal. Cuerpo filtro: acero extrusionado.
- Válvula de by-pass: Apertura diferencial 6 bar.
- Conexiones disponibles estándar: 1/2"-3/4"-1"-1 1/4"-1 1/2" bspp. Rosca especial bajo pedido.
- Elemento filtrante disp. estándar: 3-5-10-25 Micron abs. en microfibra. Otras filtraciones bajo pedido.
- Juntas: standar Buna-N. Bajo pedido Viton.
- Temperatura de trabajo: de -30°C a +90°C (+110°C Viton).
- Max. caudal: 450 l/min
- Presión de trabajo: 420 bar. Presión de rotura: 1260 bar
- Presión de colapso del cartucho: 21 bar o 210 bar.
- Resistencia a la fadiga: 1'000'000 ciclos (0÷420 bar).
- Prueba realizada según normativa: ISO 2941 / ISO 3724 / ISO 3968.

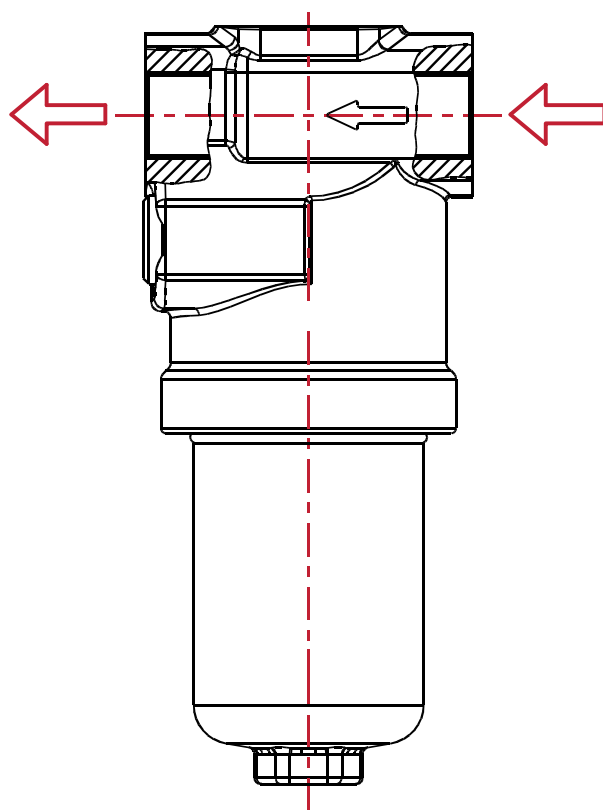

# PF41-42-43

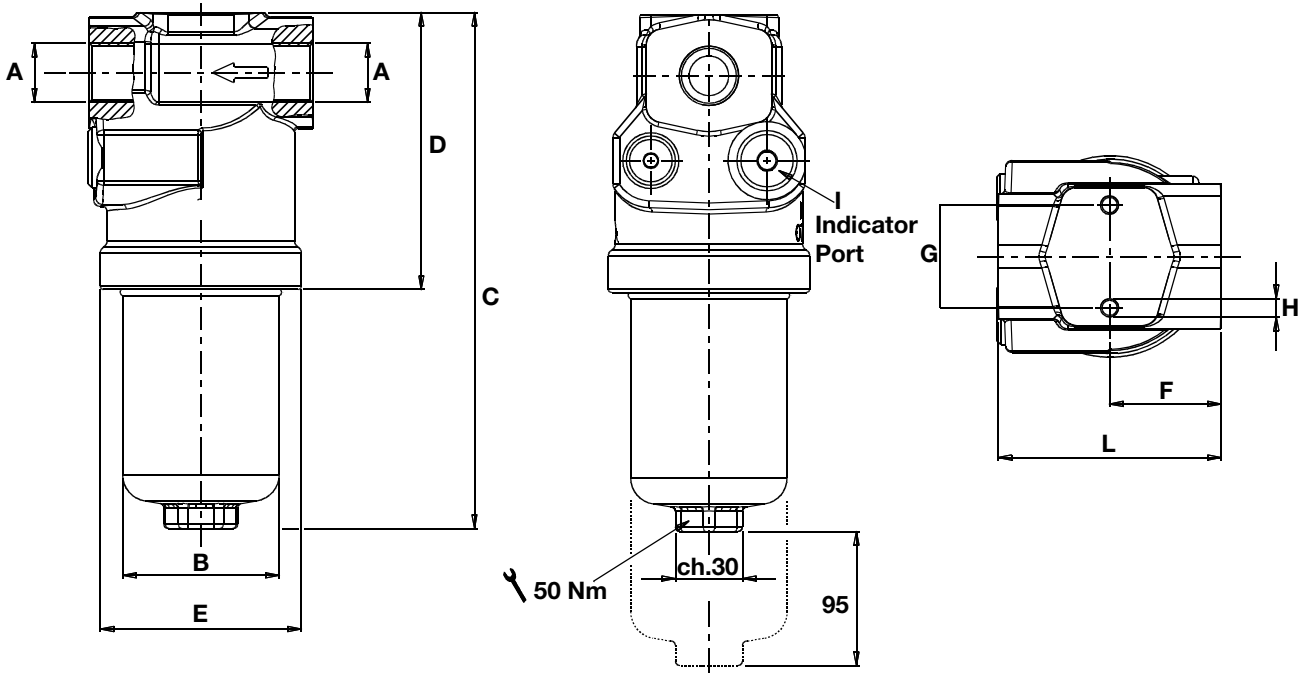

## FILTRO COMPLETO ALTA PRESSIONE 420 bar - HIGH PRESSURE COMPLETE FILTER 420 bar

Mod.	DIMENSIONI mm - DIMENSIONS mm										PESO - WEIGHT
	A	B	C	D	E	F	G	H	I	L	kg.
PF41	1/2" bspp 3/4" bspp	70	210	125	90	50	46	M8	1/2" bspp	100	5,3
PF42		70	235	125	90	50	46	M8	1/2" bspp	100	5,7
PF43		70	330	125	90	50	46	M8	1/2" bspp	100	7,2

# PF44-45

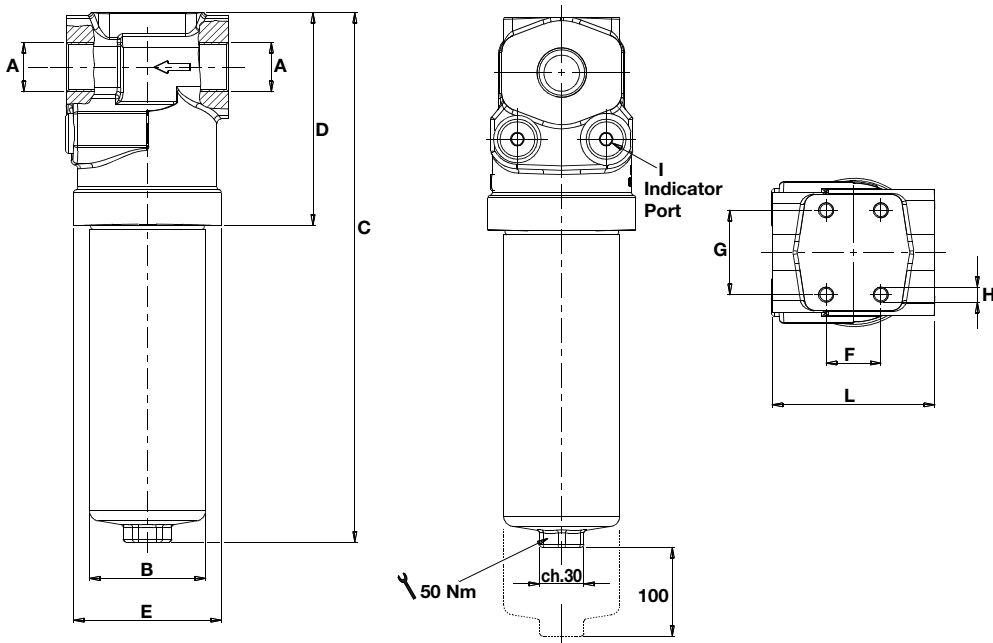

## FILTRO COMPLETO ALTA PRESSIONE 420 bar - HIGH PRESSURE COMPLETE FILTER 420 bar

Mod.	DIMENSIONI mm - DIMENSIONS mm										PESO - WEIGHT
	A	B	C	D	E	F	G	H	I	L	kg.
PF44	3/4" bspp 1" bspp	79	250	145	100	37	57	M10	1/2"bspp	110	8,2
PF45		79	360	145	100	37	57	M10	1/2"bspp	110	10,0

# PF46-47-48-49

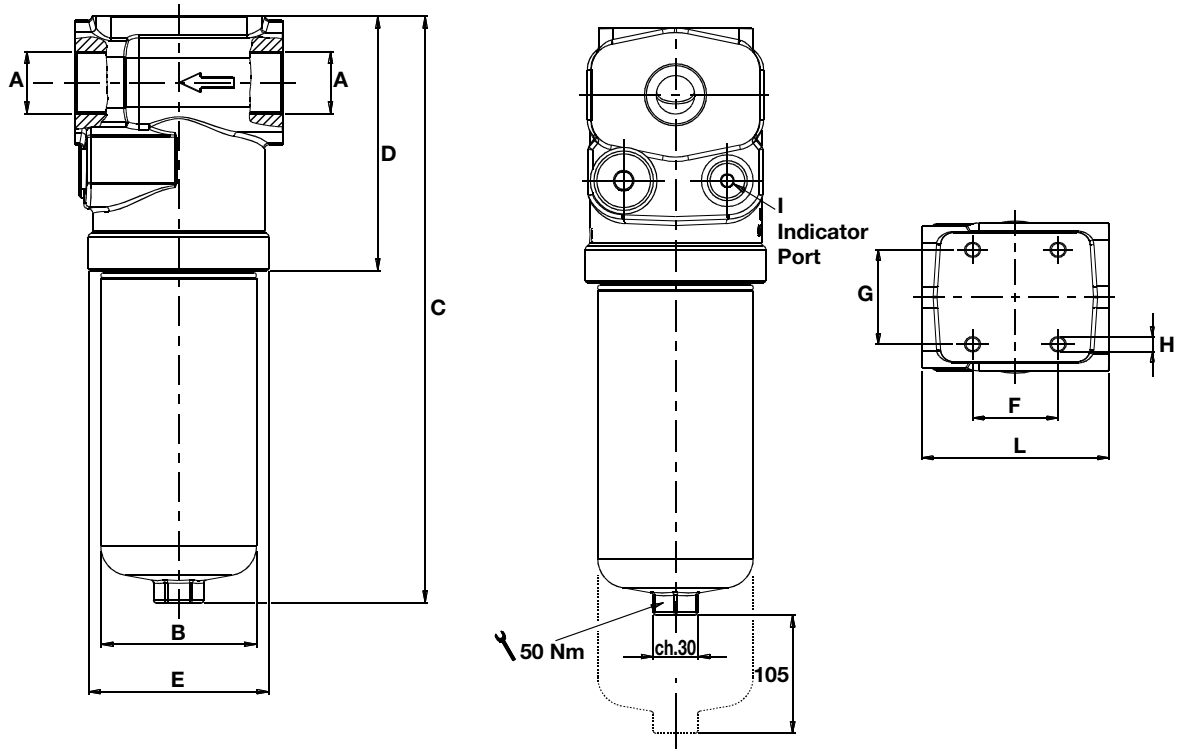

## FILTRO COMPLETO ALTA PRESSIONE 420 bar - HIGH PRESSURE COMPLETE FILTER 420 bar

Mod.	DIMENSIONI mm - DIMENSIONS mm										PESO - WEIGHT
	A	B	C	D	E	F	G	H	I	L	kg.
PF46		105	305	172	122	64	76	M12	1/2" bspp	140	15,2
PF47	1" bspp	105	400	172	122	64	76	M12	1/2" bspp	140	18,0
PF48	1"1/4 bspp	105	545	172	122	64	76	M12	1/2" bspp	140	22,0
PF49	1"1/2 bspp	105	690	172	122	64	76	M12	1/2" bspp	140	28,5



# COME ORDINARE UN FILTRO COMPLETO:

HOW TO ORDER A COMPLETE FILTER:

<b>PF4</b>	<b>1</b>	<b>A10</b>	<b>E</b>	<b>B</b>	
<b>Filtro completo</b> Complete filter	<b>Dimensioni</b> Dimensions	<b>Elemento filtrante</b> Filter Element	<b>Filetto</b> Thread	<b>Valvola by-pass</b> By-pass valve	<b>Tipo di indicatore</b> Indicator type
420 bar	Vedi tabella pag. 63/64 See table page 63/64	<b>ΔP 21 bar</b>	<b>PF41/42/43</b>	con by-pass taratura 6 bar with by-pass setting 6 bar	senza without
		<b>A03</b> MICROFIBRA 3μm abs 3μm MICROFIBERGLASS abs	<b>D</b> 1/2" bspp	<b>S</b> senza by-pass without by-pass	<b>T</b> Differenziale visivo Visual differential
		<b>A05</b> MICROFIBRA 5μm abs 5μm MICROFIBERGLASS abs	<b>E</b> 3/4" bspp		<b>U</b> Elettrico diff. visivo Visual electr. differential
		<b>A10</b> MICROFIBRA 10μm abs 10μm MICROFIBERGLASS abs	<b>PF44/45</b>		
		<b>A25</b> MICROFIBRA 25μm abs 25μm MICROFIBERGLASS abs	<b>E</b> 3/4" bspp		
		<b>ΔP 210 bar</b>	<b>PF46/47/48/49</b>		
		<b>H03</b> MICROFIBRA 3μm abs 3μm MICROFIBERGLASS abs	<b>F</b> 1" bspp		
		<b>H05</b> MICROFIBRA 5μm abs 5μm MICROFIBERGLASS abs	<b>G</b> 1"1/4 bspp		
		<b>H10</b> MICROFIBRA 10μm abs 10μm MICROFIBERGLASS abs	<b>H</b> 1"1/2 bspp		
		<b>H25</b> MICROFIBRA 25μm abs 25μm MICROFIBERGLASS abs			

# COME ORDINARE LA CARTUCCIA DI RICAMBIO:

HOW TO ORDER THE REPLACEMENT ELEMENT:

	<b>PE4</b>	.	<b>1</b>	<b>A10</b>		
	<b>Cartuccia*</b> Cartridge*	<b>Ricambio per</b> Replacement for	<b>Elemento filtrante</b> Filter Element	<b>Guarnizione</b> Gasket		
	<b>DIMENSIONI mm</b> <b>DIMENSIONS mm</b>		<b>PF41</b>	<b>PE4.1</b>	standard NBR	
	<b>Mod.</b>	<b>A</b>	<b>B</b>	<b>C</b>	<b>PF42</b>	<b>PE4.2</b>
	<b>PE4.1</b>	25,5	47	86	<b>PF43</b>	<b>PE4.3</b>
	<b>PE4.2</b>	25,5	47	115	<b>PF44</b>	<b>PE4.4</b>
	<b>PE4.3</b>	25,5	47	208	<b>PF45</b>	<b>PE4.5</b>
	<b>*PE4.4</b>	27,5	54	122	<b>PF46</b>	<b>PE4.6</b>
	<b>*PE4.5</b>	27,5	54	229	<b>PF47</b>	<b>PE4.7</b>
	<b>PE4.6</b>	40,3	80	140	<b>PF48</b>	<b>PE4.8</b>
	<b>*PE4.7</b>	40,3	80	235	<b>PF49</b>	<b>PE4.9</b>
	<b>*PE4.8</b>	40,3	80	380		<b>V</b> Viton (su richiesta) Viton (upon request)
<b>*PE4.9</b>	40,3	80	520			

\* Cartuccia tipo USA disponibile su richiesta (vedi pag. 67)  
\*USA element type available upon request (see page 67)

**Portate PF4\*\***Portate in l/min. rilevate con  
Dp=0,75 bar**PF4 flow rates\*\***Flow rate in l/min. measured with  
Dp=0,75 bar**Filtredurchfluß PF4\*\***Filterdurchfluß in l/min. gemessen  
bei Dp=0,75 bar**Débîts PF4\*\***Débîts en l/min. mesurés avec  
Dp=0,75 bar**Caudales PF4\*\***Débîts en l/min. mesurés avec  
Dp=0,75 bar

ELEMENTO FILTRANTE FILTERING ELEMENT		MICROFIBRA / FIBERGLASS			
Mod.	FILETTO - THREAD BSP	A03 3 MICRON ABS	A05 5 MICRON ABS	A10 10 MICRON ABS	A25 25 MICRON ABS
PF41	1/2"	25	30	35	45
	3/4"	25	30	35	45
PF42	1/2"	35	40	50	60
	3/4"	35	40	50	60
PF43	1/2"	60	65	75	85
	3/4"	65	70	80	95
PF44	3/4"	60	65	80	100
	1"	60	70	85	105
PF45	3/4"	105	120	135	155
	1"	110	125	145	170
PF46	1"	140	160	185	215
	1"1/4	145	165	200	240
	1"1/2	150	170	205	245
PF47	1"	210	230	255	280
	1"1/4	235	255	290	330
	1"1/2	240	265	305	350
PF48	1"	270	280	295	310
	1"1/4	315	335	360	385
	1"1/2	330	355	385	420
PF49	1"	295	300	310	320
	1"1/4	360	375	390	410
	1"1/2	385	400	425	450

\*\* Portate rilevate con olio avente viscosità cinematica di 30 cSt e densità 0.86 kg/dm<sup>3</sup>\*\* Flow rates measured with oil of 30 cSt kinematic viscosity and 0.86 kg/dm<sup>3</sup>

• Compatibilità con fluidi: oli minerali (HH-HL-HM-HR-HV-HG) e fluidi sintetici (HS-HFDR-HFDU-HFDS).

• Fluid compatibility: mineral oil (HH-HL-HM-HR-HV-HG) and synthetic fluids (HS-HFDR-HFDU-HFDS).

**Capacità d'accumulo  
Cartucce PE4  
(ISO MTD)**

Δp=5 bar

**PE4 element dirt  
holding capacity  
(ISO MTD)**

Δp=5 bar

**Element PE4  
Schmutzanz-  
sammlungskapazität  
(ISO MTD)**

Δp=5 bar

**Capacità  
d'accumulation  
cartouches PE4  
(ISO MTD)**

Δp=5 bar

**Capacidad de  
retención cartuchos  
PE4 (ISO MTD)**

Δp=5 bar

ELEMENTO FILTRANTE FILTERING ELEMENT			MICROFIBRA / FIBERGLASS			
Mod.	C mm	SUPERFICIE FILTRANTE FILTERING SURFACE cm <sup>2</sup>	A03 3 MICRON ABS gr	A05 5 MICRON ABS gr	A10 10 MICRON ABS gr	A25 25 MICRON ABS gr
PE4.1	86	380	2,10	2,70	3,00	4,40
PE4.2	115	500	3,00	3,90	4,40	6,40
PE4.3	208	950	5,30	6,70	7,50	11,00
PE4.4	122	900	5,10	6,50	7,30	10,50
PE4.5	229	1800	10,10	13,00	14,50	21,00
PE4.6	140	2000	11,00	14,50	16,00	23,00
PE4.7	235	3400	19,00	24,00	27,00	39,00
PE4.8	380	5500	30,00	34,00	43,00	63,00
PE4.9	520	7700	42,00	54,00	60,00	87,00

# INDICATORI INTASAMENTO CLOGGING INDICATORS - VERSCHMUTZUNGSANZEIGEN - INDICATEURS DE COLMAGE - INDICADORES DE SUCIEDAD

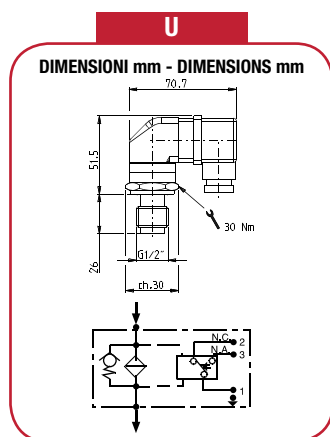
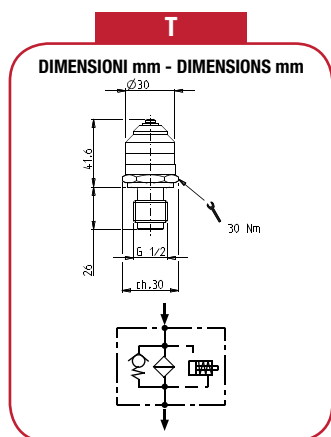

SERIE SERIES	TARATURA SETTING	TIPO TYPE
<b>T</b>	8 bar (no by-pass) 5 bar (by-pass)	Differenziale visivo Visual differential Optisch Differenzdruckanzeige Differential visuel Visual Diferencial
<b>U</b>	8 bar (no by-pass) 5 bar (by-pass)	Elettrico differenziale visivo IP65 - 250Vac Visual electrical differential IP65 - 250Vac Optisch El. Differenzdruckanzeige IP65 - 250Vac Differential visuel el. IP65 - 250Vac Visual Diferencial el. IP65 - 250Vac

## CARTUCCIA “TIPO USA” DISPONIBILE SU RICHIESTA:

“USA ELEMENT TYPE” AVAILABLE UPON REQUEST:

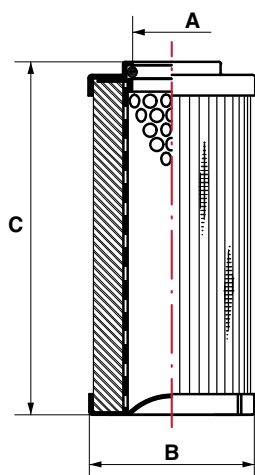

DIMENSIONI mm - DIMENSIONS mm			
Mod.	A	B	C
<b>PE4.4_U</b>	24,5	53	115
<b>PE4.5_U</b>	24,5	53	210
<b>PE4.7_U</b>	43,2	80	210
<b>PE4.8_U</b>	43,2	80	328
<b>PE4.9_U</b>	43,2	80	428

# Accessori per serbatoio idraulico

## SERIE LO-SL-TP-FAS-PV



**GB** Hydraulic tank accessories

**D** Hydrauliktankzubehör

**FR** Accessoires pour reservoir hydraulique

**ES** Accesorios para deposito hidraulico



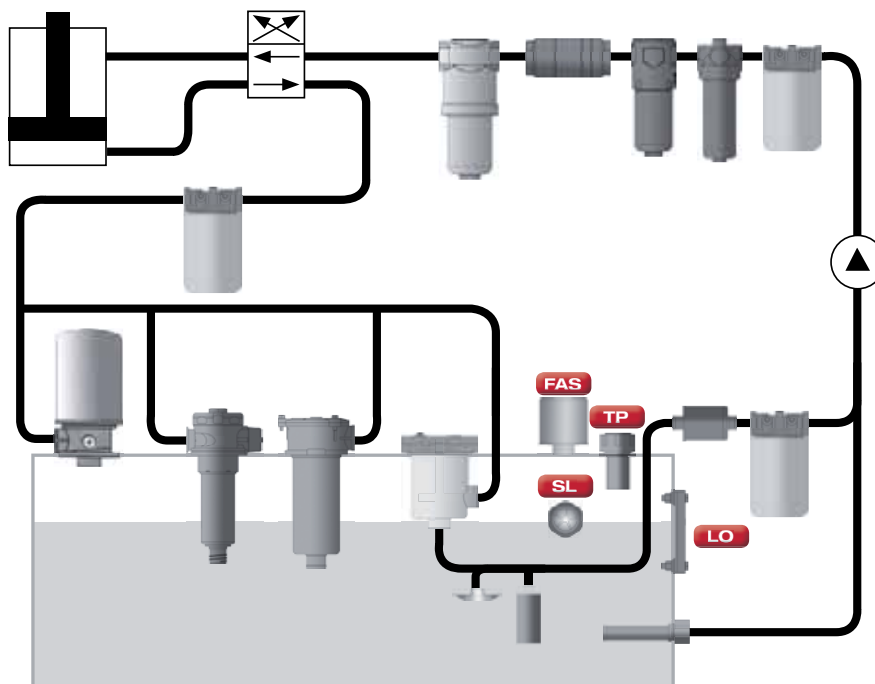

**IT** Gli accessori serie LO-SL-TP-FAS-PV sono stati concepiti per completare la nostra ampia gamma di filtri, per poter offrire al cliente la possibilità di avere, da un unico fornitore, componenti di elevata qualità necessari per l'allestimento completo del serbatoio idraulico.

Si tratta infatti di componenti essenziali per il controllo del fluido e delle funzioni principali dell'impianto:

- Gli indicatori di livello olio visivi serie LO permettono di visualizzare il livello e la temperatura del fluido nel serbatoio.
- Le spie livello olio serie SL-SLM consentono, con la massima economia, il controllo del livello del fluido anche nei piccoli spazi.
- I tappi di carico serie TP-TPL si utilizzano per il riempimento del serbatoio e la filtrazione dell'aria scambiata con l'esterno.
- Gli sfiati aria serie FAS sono montati per filtrare l'aria in ingresso nel serbatoio ed impedire l'ingresso al contaminante.
- I serbatoi/barilotti di compensazione serie PV consentono l'immagazzinaggio al loro interno di piccole quantità di olio in totale sicurezza.

**EN** The accessories series LO-SL-TP-FAS-PV are designed to complete our wide range of filters, in order to give customers the possibility to source, from a single supplier, high quality components needed for the full assembly of the hydraulic tank. They are essential components to inspect the fluid and all main system functions:

- The visual oil level indicators series LO allow to check the level and temperature of tank's fluid.
- The oil level windows series SL-SLM are designed to inspect the oil level also in narrow spaces and with maximum cost savings.
- The filler breathers series TP-TPL are used for tank filling and filtration of air exchanged with outside atmosphere.
- The breathers series FAS are mounted to filter the intake air and avoid contaminant access.
- The compensation tanks/barrels PV series allow a total safe storage of small amounts of oil.

**D** Die Zubehörserie LO-SL-TP-FAS-PV ergänzt unsere Filterauswahl und bietet dem Kunden die Möglichkeit, alle für die Montage von Hydrauliktanks benötigten Qualitätskomponenten „aus einer Hand“ zu erwerben. Besagte Komponenten sind wesentliche Bestandteile, um bspw. den Flüssigkeitsstand zu kontrollieren oder wichtige Systemfunktionen zu überwachen:

- Die visuellen Ölstandsanzeiger der Serie LO ermöglichen das Prüfen von Ölstand und -Temperatur.
- Die Schauglas-Serie SL/SLM dient der Ölstandskontrolle auch auf engem Raum - eine preiswerte Alternative.
- Die Einfüll- und Belüftungsfilter der TP/TPL-Serie werden zum Befüllen von Tanks bei gleichzeitiger Filtrierung der einströmenden Luft verbaut.
- Die Trockenluftfilterserie FAS wird zur Ansaugluft-Filtration und Schadstoffkontrolle verwendet.
- Die Ausgleichsbehälter der PV-Serie ermöglichen die sichere Lagerung von kleineren Ölmengen.

**FR** Les accessoires Série LO-SL-TP-FAS-PV sont conçus pour compléter notre large gamme de filtres, afin d'offrir au clients la possibilité d'avoir, chez une unique source, composants de haute qualité nécessaires pour la production complète du réservoir hydraulique. Il s'agit en effet des composants essentiels pour le contrôle des fluides et les fonctions principales du système:

- La série LO d'indicateurs optiques permet de visualiser le niveau et la température du fluide dans le réservoir.
- La série SL-SLM de hublot huile permet, avec la plus grande économie, de contrôler le niveau du fluide même dans les petits espaces.
- Les bouchons reniflards série TP-TPL sont utilisés pour remplir le réservoir et pour la filtration de l'air échangé avec l'extérieur.
- Les filtres air reniflards série FAS sont montés pour filtrer l'air entrant dans le réservoir et empêcher l'entrée du contaminant.
- Les réservoirs/barillets de compensation série PV, permettent un stockage sûr de petites quantités d'huile.

**ES** Los accesorios Serie LO-SL-TP-FAS-PV están diseñados para complementar nuestra amplia gama de filtros, con el fin de ofrecer los clientes la posibilidad de obtener, de una sola fuente, componentes de alta calidad necesarios para el conjunto completo de depósito hidráulico. De hecho, son componentes esenciales para el control del fluido y las funciones principales del sistema:

- Los indicadores visuales serie LO permite ver el nivel y la temperatura del líquido en el tanque.
- Los indicadores de nivel de aceite serie SL-SLM permite, con la mayor economía, controlar el nivel de fluido también en espacios reducidos.
- Los tapones de carga serie TP-TPL se utilizan para rellenar el tanque y para la filtración de l'aire intercambiada con el exterior.
- Los filtros respiraderos serie FAS están montados para filtrar el aire que entra en el tanque y evitar la entrada de los contaminantes.
- Los tanques/barrilejos de compensación serie PV permiten el almacenamiento de pequeñas cantidades de aceite en total seguridad.

# SERIE LO

## IT Indicatori visivi di livello olio (con o senza termometro)

### CARATTERISTICHE TECNICHE:

- Corpo: "Trogamid".
- Testine chiusura: in nylon (plastica).
- Protezione esterna: alluminio anodizzato.
- Viti: acciaio zincato.
- Guarnizioni: standard Buna-N. Su richiesta Viton.
- Interassi standard di foratura: 76-127-254 mm. Altre misure su richiesta.
- Termometro (se richiesto): a bulbo, incorporato nel livello con doppia scala °C (scala 0°C/+100°C) e °F (scala 30°F/210°F).
- Temperatura esercizio: da -20°C a +80°C.
- Pressione max. di esercizio: 1 bar.
- Coppia di serraggio: 10 Nm.

## EN Visual oil level indicators (with or without thermometer)

### TECHNICAL FEATURES:

- Body: "Trogamid" glass.
- Closing heads: nylon (plastic).
- External protection: extruded aluminium.
- Screws: galvanized steel.
- Seals: Buna-N standard. Viton upon request.
- Standard drilling distance: 76-127-254 mm. Other dimensions upon request.
- Thermometer (if required): bulb, incorporated into oil level with double scale °C (scale 0°C/+100°C) and °F (scale 30°F/210°F).
- Operating temperature: from -20°C to +80°C.
- Max. working pressure: 1 bar.
- Tightening Torque: 10 Nm.

## D Optische Ölstandanzeigen (mit oder ohne Thermometer)

### TECHNISCHE DATEN:

- Körper: "Trogamid" Glas.
- Schließköpfe: Nylon (Kunststoff).
- Außenschutz: eloxiertem Aluminium.
- Schrauben: verzinktem Stahl.
- Dichtungen: Buna-N Standard. Viton auf Wunsch.
- Standard Bohrabstand: 76-127-254 mm. Andere Abmessungen auf Anfrage.
- Thermometer (falls erforderlich): Kugel mit doppelter Skala im Ölstand integriert °C (Skala 0°C/+100°C) und °F (Skala 30°F/210°F).
- Betriebstemperatur: von -20°C bis +80°C.
- Max. Betriebsdruck: 1 bar.
- Bolzendrehmoment: 10 Nm.

## FR Indicateurs optiques de niveau huile (avec ou sans thermomètre)

### CARACTERISTIQUES TECHNIQUES:

- Corp: verre "Trogamid".
- Têtes de fermeture: Nylon (plastique).
- Protection externe: aluminium anodisé.
- Vis: acier galvanisé.
- Joints: Buna-N standard. Viton sur demande.
- Entraxe standard: 76-127-254 mm. Autres dimensions sur demande.
- Thermomètre (si demandé): boule intégré dans l'indicateur avec double échelle °C (éch. 0°C/+100°C) et °F (éch. 30°F/210°F).
- Temperature de travail: de -20°C à +80°C.
- Max. pression de service: 1 bar.
- Couple de serrage: 10 Nm.

## ES Indicadores nivel aceite visual (con o sin termómetro)

### CARACTERÍSTICAS TÉCNICAS:

- Cuerpo: vidrio "Trogamid".
- Cabezas de cierre: Nylon (plástico).
- Protección externa: aluminio anodizado.
- Tornillos: acero galvanizado.
- Juntas: estándar Buna-N. Bajo pedido Viton.
- Distancia entre ejes estándar: 76-127-254 mm. Otros tamaños bajo pedido.
- Termómetro: bulbo incluido en el nivel con doble escala °C (esc. 0°C/+100°C) y °F (esc. 30°F/210°F).
- Temperatura de trabajo: de -20°C a +80°C.
- Presión max. de trabajo: 1 bar.
- Par de apriete: 10 Nm.

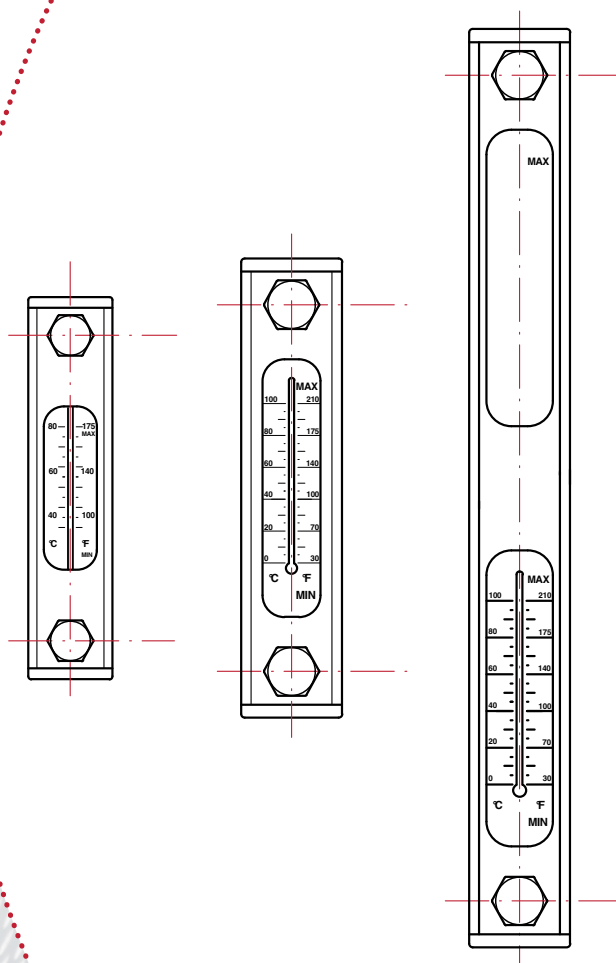

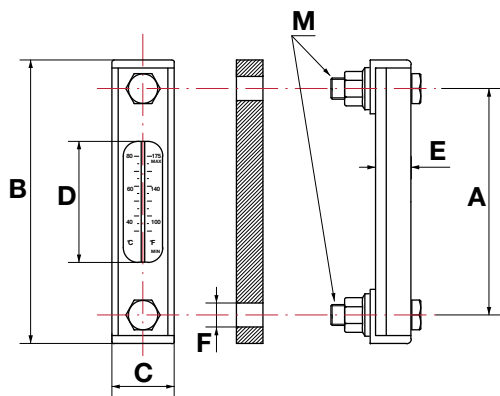

## LO5.076

### INTERASSE FORATURA 76 mm - DRILLING DISTANCE 76 mm

Mod.	DIMENSIONI mm - DIMENSIONS mm							
	A	B	C	D	E	M	F Ø MIN.	F Ø MAX.
LO5.076ST	76	106	36	41	21	Standard M10	10,5 - 11	
LO5.076TE								
LO5.076ST1						(1) M12	12,5 - 13	
LO5.076TE1								

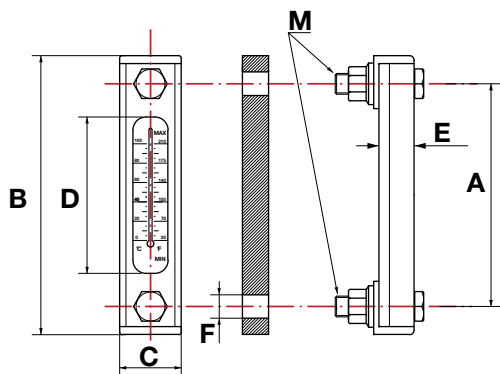

## LO5.127

### INTERASSE FORATURA 127 mm - DRILLING DISTANCE 127 mm

Mod.	DIMENSIONI mm - DIMENSIONS mm							
	A	B	C	D	E	M	F Ø MIN.	F Ø MAX.
LO5.127ST	127	159	36	86	21	Standard M12	12,5 - 13	
LO5.127TE								
LO5.127ST1						(1) M10	10,5 - 11	
LO5.127TE1								

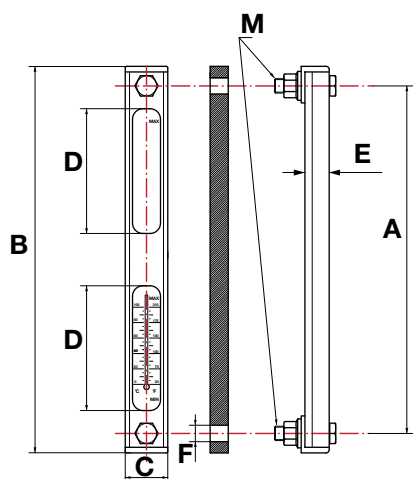

## LO5.254

### INTERASSE FORATURA 254 mm - DRILLING DISTANCE 254 mm

Mod.	DIMENSIONI mm - DIMENSIONS mm							
	A	B	C	D	E	M	F Ø MIN.	F Ø MAX.
LO5.254ST	254	285	36	2x86	21	Standard M12	12,5 - 13	
LO5.254TE								
LO5.254ST1						(1) M10	10,5 - 11	
LO5.254TE1								

## COME ORDINARE UN INDICATORE LIVELLO OLIO:

HOW TO ORDER AN OIL LEVEL INDICATOR:

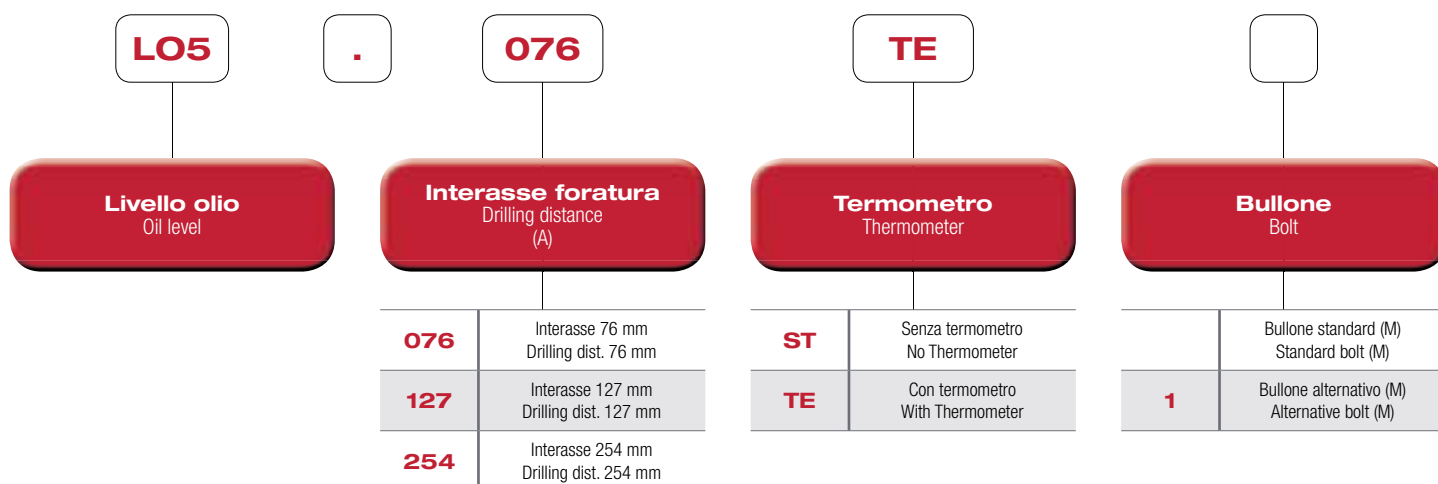



# SERIE SL

## IT Spie livello olio in plastica o metallo

### CARATTERISTICHE TECNICHE:

- Corpo: versione plastica in resina poliammidica. Versione metallo in lega di alluminio.
- Visore (versione metallo): resina poliammidica "Trogamid". Versione HP in vetro.
- Guarnizioni: standard in fibra. Versione HP in viton.
- Pressione max. di esercizio (versione metallo): 10 bar. Versione HP 20 bar.
- Temperatura di esercizio: da - 30°C a + 90°C. Versione HP +130°C.
- Evitare il contatto con alcool, liquidi contenenti alcool, acqua oltre 80°C e liquidi refrigeranti ad alte temperature (versione resina "Trogamid").
- È possibile fornire versione in metallo per alta temperatura e pressione fino a 20 bar (SLM.HP).

## EN Visual oil level windows in plastic or metal

### TECHNICAL FEATURES:

- Body: plastic version in polyamide resin. Metal version in aluminium alloy.
- Viewer (metal version): polyamide resin "Trogamid". HP version in natural glass.
- Gaskets: standard in fiber. HP version in viton.
- Max. Working pressure (metal version): 10 bar. HP version 20 bar.
- Working temperature: from -30°C to + 90°C. HP version +130°C .
- Avoid contact with alcohol, liquids containing alcohol, water over 80°C and coolant at high temperatures ("Trogamid" resin version).
- Metal version for high temperatures and pressure up to 20 bar is available (SLM.HP).

## D Kunststoff oder Metall Ölstandanzeiger

### TECHNISCHE DATEN:

- Gehäuse: Kunststoff-Version in Polyamidharz. Metallausführung in Aluminium-Legierung.
- Visor (Metallausführung): Polyamid-Harz "Trogamid". HP Version in glas.
- Dichtung: standard aus Faser. HP Version in Viton.
- Max. Betriebsdruck (Metallausführung): 10 bar. HP Version 20 bar.
- Betriebstemperatur: von - 30°C bis + 90°C. HP Version +130°C.
- Kontakt mit Alkohol, Flüssigkeiten mit Alkohol, Wasser über 80°C und Kühlmittel bei hohen Temperaturen zu vermeiden ("Trogamid" Polyamidharz version).
- Metallausführung für hohe Temperaturen und Drücke bis 20 bar ist erhältlich (SLM.HP).

## FR Indicateurs optiques de niveau huile en plastique ou en métal

### CARACTERISTIQUES TECHNIQUES:

- Corp: Version en plastique en résine de polyamide. Version métallique en alliage d'aluminium.
- Viseur (version en métal): résine de polyamide "Trogamid". Version HP en verre.
- Joint: standard en fibre. Version HP en Viton.
- Max. pression de travaille (version en métal): 10 bar. Version HP 20 bar.
- Temperature de travaille: de - 30°C à + 90°C. Version HP+130°C.
- Eviter le contact avec alcool, liquides contenant alcool, eau plus de 80°C et liquides refroidissement à températures élevées (version résine "Trogamid").
- Version en métal pour hautes températures et pressions jusqu'à 20 bar est disponible (SLM.HP).

## ES Indicadores nivel aceite plástico o metal

### CARACTERÍSTICAS TÉCNICAS:

- Cuerpo: versión de plástico en resina de poliamida. Versión metal en aleación de aluminio.
- Visor (Versión metal): resina de poliamida "Trogamid". Vidrio para Versión HP.
- Juntas: estándar en fibra. Viton para versión HP.
- Presión max. de trabajo (Versión metal): 10 bar. Versión HP 20 bar.
- Temperatura de trabajo: de - 30°C a + 90°C. Versión HP+130°C.
- Evite el contacto con el alcohol, líquidos que contengan alcohol, el agua más de 80°C y líquido refrigerante a alta temperatura (version resina "Trogamid").
- Está disponible la versión en metal para alta temperatura y presión hasta 20 bar (SLM.HP).

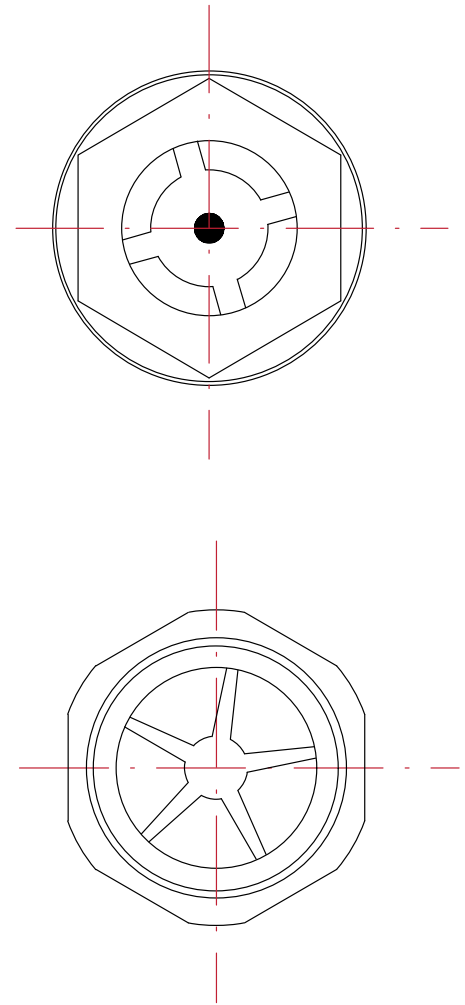



# SL

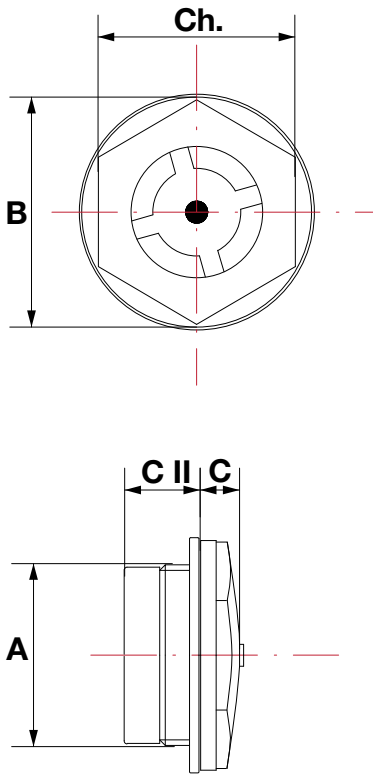

## VERSIONE IN PLASTICA - PLASTIC VERSION

Mod.	DIMENSIONI mm - DIMENSIONS mm					SERRAGGIO Nm TIGHTENING Nm
	A	B	C	C II	Ch	
SL.14	1/4" bspp	20,5	8	8,50	17	8
SL.38	3/8" bspp	22	6,5	12	18	12
SL.12	1/2" bspp	28	8	12	24	16
SL.34	3/4" bspp	36	8,5	13,5	30	21
SL.1	1" bspp	42	9	14	36	24
SL.114	1" 1/4 bspp	51	10	17	42	
SL.112	1" 1/2 bspp	58	10	21	50	
SL.2	2" bspp	74	12	20	64	
SL.1415	M14x1,5	20	7,5	8	17	8
SL.1615	M16x1,5	22	6,5	12,5	18	12
SL.1815	M18x1,5	25,5	6	12,5	21	12
SL.2015	M20x1,5	28	7,5	12	24	16
SL.2215	M22x1,5	28	7,5	12,5	24	16
SL.4015	M40x1,5	51	10	17	42	

# SLM

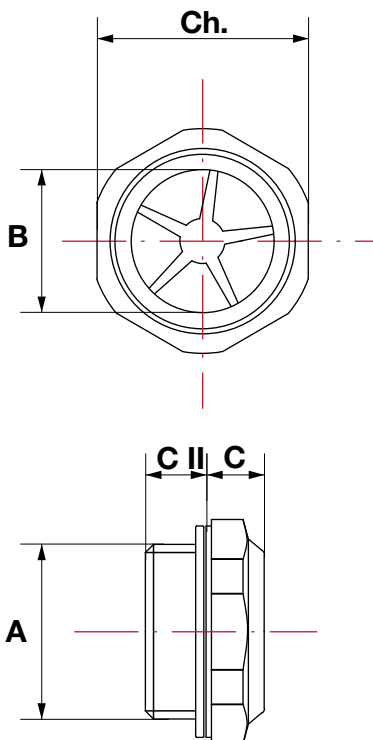

## VERSIONE IN METALLO - METAL VERSION

Mod.	DIMENSIONI mm - DIMENSIONS mm				
	A	B	C	C II	Ch
SLM.14	1/4" bspp	11	9,50	7,50	18
SLM.38	3/8" bspp	13	10	9	22
SLM.12	1/2" bspp	16	10	9	27
SLM.34	3/4" bspp	20	9	12	32
SLM.1	1" bspp	26	11	11	40
SLM.114	1" 1/4 bspp	34	14	12	50
SLM.1815	M18x1,5	13	10	9	22
SLM.2215	M22x1,5	16	10	9	27
SLM.12HP	1/2" bspp	12	11	9	27
SLM.34HP	3/4" bspp	16	10	11	32
SLM.1HP	1" bspp	23	11	11	40

# SERIE TP

## IT Tappi di riempimento con sfiato aria e filtro interno.

### CARATTERISTICHE TECNICHE:

- Coperchio: acciaio cromato.
- Flangia (dove prevista): acciaio zincato.
- Cestello prefiltraggio olio (dove previsto): tela metallica microstirata.
- Filtro aria interno: in spugna 40 micron nom. o in carta 10 micron nom. Altre filtrazioni su richiesta.
- Valvola pressurizzazione (dove prevista): in plastica interna al coperchio.
- Viti a corredo (dove previste): TC M005x012 UNI6107 in acciaio zincato.
- Guarnizioni (dove previste): carta / sughero per versione con cestello. Buna-N per versione pressurizzata.

## EN Filler caps with inner air breather and filter.

### TECHNICAL FEATURES:

- Cover: chrome plated steel.
- Flange (when provided): galvanized steel.
- Pre-filtering oil basket (when provided): galvanized microexpanded mesh.
- Inner air filter: 40 micron nom. foam or 10 micron nom. paper. Other filter elements available upon request.
- Pressurization valve (when provided): in plastic, inside the cover.
- Additional screws (when provided): TC M005x012 UNI6107 in galvanized steel.
- Seals (when provided): paper / cork for basket version. Buna-N for pressurized version.

## D Füllpropfen mit Belüftungsfiter und Einfüllsieb.

### TECHNISCHE DATEN:

- Deckel: Chromstahl.
- Flansch (sofern vorhanden): verzinktem Stahl.
- Pre-Filtering Ölkorb (sofern vorhanden): verzinktem Mikro Streckmetall.
- Inneren Luftfilter: 40 Mikron nom. Schwamm oder 10 Mikron Papier nom. Weitere Materialien auf Anfrage erhältlich.
- Überdruckventil (sofern vorhanden): aus Kunststoff, im Deckel.
- Extra Schrauben (sofern vorhanden): TC M005x012 UNI6107 aus verzinktem Stahl.
- Dichtungen: Papier / Kork für Korbmodell. Buna-N für Ventilmodell.

## F Bouchons de remplissage avec reniflard filtrant.

### CARACTERISTIQUES TECHNIQUES:

- Couvercle: acier chromé.
- Bride (quand prévue): acier galvanisé.
- Panier préfiltrage huile (quand prévu): métal déployé micro.
- Filtre air intérieur: éponge 40 micron nom. ou papier 10 micron nom. Autres filtrations sur demande.
- Soupape pressurisée (quand prévue): en plastique, dans le couvercle.
- Vis extra (quand prévues): TC M005x012 UNI6107 en acier galvanisé.
- Joints: papier / cork pour version avec panier. Buna-N pour version soupape.

## ES Tapones de carga con filtro respiradero

### CARACTERÍSTICAS TÉCNICAS:

- Cabeza: acero cromado.
- Brida: acero galvanizado.
- Canasta prefiltro aceite (si prevista): tela metálica expandida.
- Filtro aire interno: esponja 40 micron nom. o papel 10 micron nom. Otras filtraciones bajo pedido.
- Válvula de presurización (si prevista): en plástico, en la cubierta.
- Tornillos adicionales (si previstos): TC M005x012 UNI6107 en acero galvanizado.
- Juntas: papel / corcho versión canasta. Buna-N versión válvula.

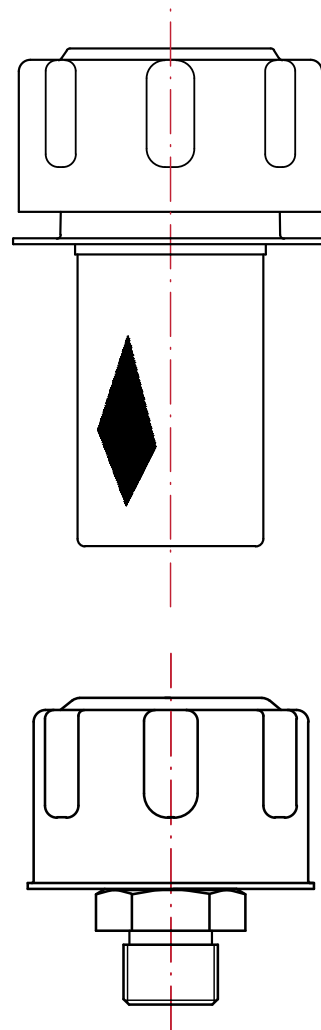

# FISSAGGIO CON VITI - SCREW FIXING

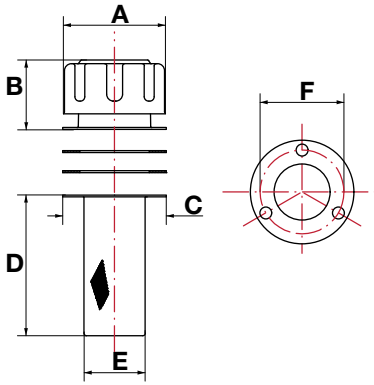

FISSAGGIO FLANGIA CON VITI (NR.3) - SCREW FIXING FLANGE (NR.3)									
Mod.	FILTRO ARIA - AIR FILTER		DIMENSIONI mm - DIMENSIONS mm						FORI FISSAGGIO MOUNTING HOLES
	Micron nom.	Portata aria m <sup>3</sup> /h Air Flow m <sup>3</sup> /h	A	B	C	D	E	F	
TP1.02600	40 (foam)	15	48	37	52	65	28	41	3
TP1.03869	10 (paper)	15	48	37	52	65	28	41	3

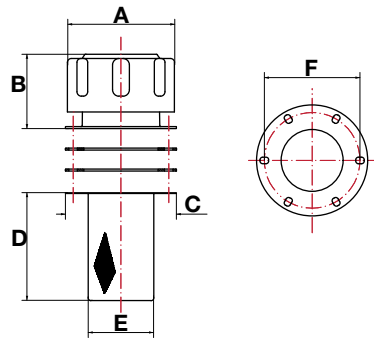

FISSAGGIO FLANGIA CON VITI (NR.6) - SCREW FIXING FLANGE (NR.6)									
Mod.	FILTRO ARIA - AIR FILTER		DIMENSIONI mm - DIMENSIONS mm						FORI FISSAGGIO MOUNTING HOLES
	Micron nom.	Portata aria m <sup>3</sup> /h Air Flow m <sup>3</sup> /h	A	B	C	D	E	F	
TP1.02601	40 (foam)	42	75	48	83	82	50	73	6
TP1.03870	10 (paper)	42	75	48	83	82	50	73	6
TP1.02602	40 (foam)	42	75	48	83	150	50	73	6
TP1.02603	40 (foam)	42	75	48	83	201	50	73	6

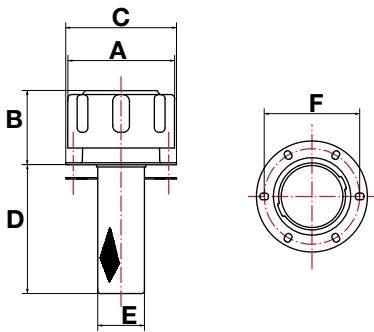

FISSAGGIO FLANGIA CON VITI (NR.6) + VALVOLA PRESSURIZZAZIONE 0,35 bar SCREW FIXING FLANGE (NR.6) + PRESSURISATION VALVE 0,35 bar									
Mod.	FILTRO ARIA - AIR FILTER		DIMENSIONI mm - DIMENSIONS mm						FORI FISSAGGIO MOUNTING HOLES
	Micron nom.	Portata aria m <sup>3</sup> /h Air Flow m <sup>3</sup> /h	A	B	C	D	E	F	
TP3.02606	40 (foam)	42	70	50	83	100	36	73	6
TP3.02607	40 (foam)	42	75	48	83	150	48	73	6

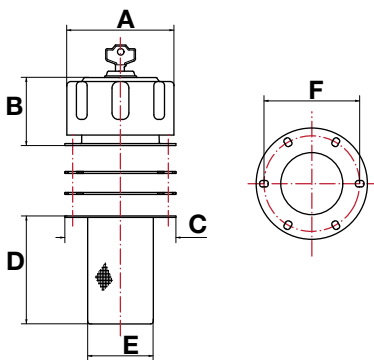

CHIUSURA CON CHIAVE E FISSAGGIO FLANGIA CON VITI - KEY LOCKING AND SCREW FIXING FLANGE									
Mod.	FILTRO ARIA - AIR FILTER		DIMENSIONI mm - DIMENSIONS mm						FORI FISSAGGIO MOUNTING HOLES
	Micron nom.	Portata aria m <sup>3</sup> /h Air Flow m <sup>3</sup> /h	A	B	C	D	E	F	
TP2.02604	40 (foam)	42	75	46	83	93	50	73	6
TP2.02605	40 (foam)	42	75	46	83	150	50	73	6

## PV9.01746

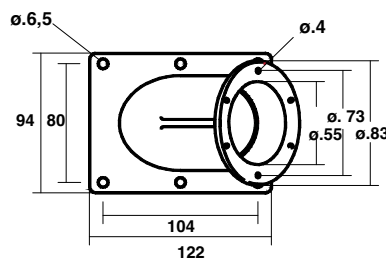
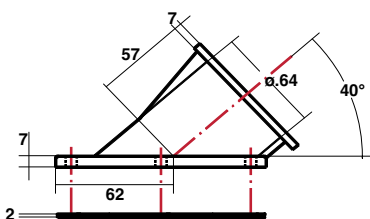

### ADATTATORE INCLINATO PER TAPPI

- Per tutti i modelli con flangia a 6 fori.
- Fornito con viti di fissaggio e guarnizione.

### ANGLED ADAPTOR FOR FILTER CAPS

- Suitable for all 6 holes fixing models.
- Supplied with fixing screws and gasket.

# FISSAGGIO A SALDARE - WELDING FIXING

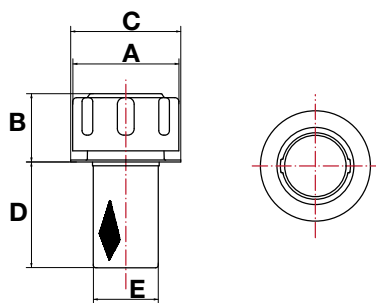

FISSAGGIO FLANGIA A SALDARE - WELDING FIXING FLANGE							
Mod.	FILTRO ARIA - AIR FILTER		DIMENSIONI mm - DIMENSIONS mm				
	Micron nom.	Portata aria m <sup>3</sup> /h Air Flow m <sup>3</sup> /h	A	B	C	D	E
TP5.02610	40 (foam)	42	75	48	84	105	38
TP7.02612*	40 (foam)	42	70	50	84	100	36

\* Versione TP7 con valvola di pressurizzazione apertura 0,35 bar.

\* TP7 version with pressurized valve opening 0,35 bar.

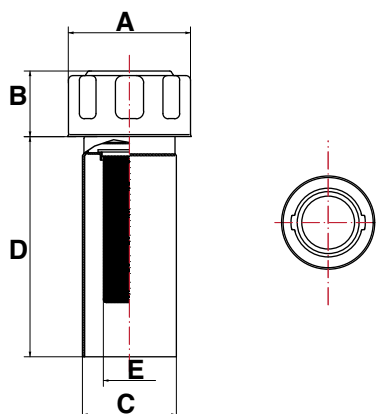

FISSAGGIO FLANGIA A SALDARE CON TUBO - WELDING FIXING FLANGE WITH PIPE							
Mod.	FILTRO ARIA - AIR FILTER		DIMENSIONI mm - DIMENSIONS mm				
	Micron nom.	Portata aria m <sup>3</sup> /h Air Flow m <sup>3</sup> /h	A	B	C	D	E
TP5.05502	40 (foam)	42	70	35	64	149	36

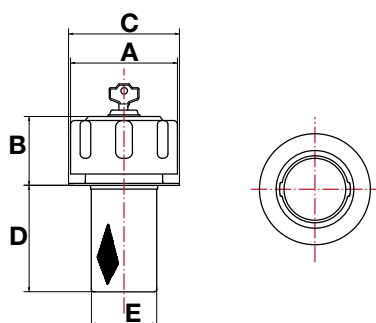

CHIUSURA CON CHIAVE E FISSAGGIO FLANGIA A SALDARE - KEY LOCKING AND WELDING FIXING FLANGE							
Mod.	FILTRO ARIA - AIR FILTER		DIMENSIONI mm - DIMENSIONS mm				
	Micron nom.	Portata aria m <sup>3</sup> /h Air Flow m <sup>3</sup> /h	A	B	C	D	E
TP6.02611	40 (foam)	42	75	48	84	105	38

# ATTACCO FILETTATO - THREAD CONNECTION

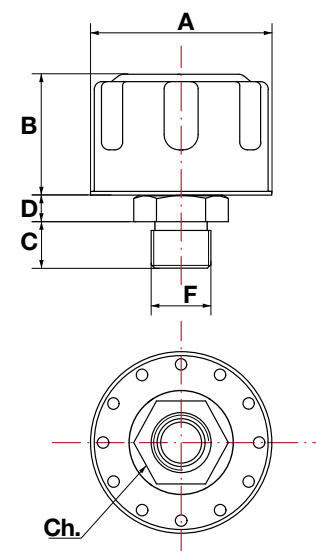

TAPPO AVVITABILE - SCREWING CAP								
Mod.	FILTRO ARIA - AIR FILTER		DIMENSIONI mm - DIMENSIONS mm					
	Micron nom.	Portata aria m <sup>3</sup> /h Air Flow m <sup>3</sup> /h	BSPP	A	B	C	D	CH
TP8.02613	40 (foam)	15	1/4"	48	30	13	9	22
TP8.05506	40 (foam)	15	1/2"	48	30	13	9	22
TP8.02614	40 (foam)	42	3/4"	76	40	20	8	32
TP8.03842	10 (paper)	42	3/4"	76	40	20	8	32
TP9.02615*	40 (foam)	42	3/4"	70	35	18	15	30
TP9.06736*	10 (paper)	42	3/4"	76	40	20	8	32

\* Versione TP9 con valvola di pressurizzazione apertura 0,35 bar.

\* TP9 version with pressurized valve opening 0,35 bar.



# SERIE TPL

**IT** Tappi di riempimento in plastica con sfiato aria e filtro interno (sostituibile).

**EN** Plastic filler caps with inner air breather and filter (replaceable).

**D** Kunststoff-Füllpropfen mit Belüftungsfilter (ersetzbar).

**F** Bouchons plastiques de remplissage avec reniflard filtrant (remplaçable).

**ES** Tapones de carga plásticos con filtro respiradero (sostituibile).

**CARATTERISTICHE TECNICHE:**

- Coperchio e corpo: in plastica (poliammide 66) / corpo colore nero – coperchio colore rosso.
- Filtro aria interno: in spugna 40 micron nom. (sostituibile). Altre filtrazioni o materiali su richiesta.
- Per applicazioni soggette a forti spruzzi di olio, suggeriamo l'utilizzo del filtro aria in bronzo sinterizzato 30 micron nom. (aggiungere "B" alla fine del codice).
- Guarnizione: NBR.
- Temperatura di esercizio: da -30°C a +100°C.

**TECHNICAL FEATURES:**

- Cover and body: in plastic (polyamide 66) / body black color – cover red color.
- Inner air filter: 40 micron nom. sponge (replaceable). Other filter elements available upon request.
- For applications subject to strong oil spray, we recommend to use a sintered bronze air filter element 30 micron nom. (add "B" to code's end).
- Seal: NBR.
- Working temperature: from -30°C / to +100°C.

**TECHNISCHE DATEN:**

- Deckel und Gehäuse: aus Kunststoff (Polyamid 66) / Gehäuse schwarz – Deckel rot.
- Inneren Luftfilter: 40 Mikron nom. Schwamm (ersetzbar). Weitere Materialien auf Anfrage erhältlich.
- Für Anwendungen mit starken Ölstrahl, empfehlen Wir eine Sinterbronze Luftfilterelement 30 Mikron nom. („B“ am Ende des Kodes hinzufügen).
- Dichtung: NBR.
- Betriebstemperatur: von -30°C bis +100°C.

**CARACTERISTIQUES TECHNIQUES:**

- Couvercle et corp: en plastique (polyamide 66) / corp noir – couvercle rouge.
- Filtre air intérieur: éponge 40 micron nom. (remplaçable). Autres filtrations sur demande.
- Pour les applications soumises à fortes embruns d'huile, nous recommandons d'utiliser un élément filtrant en bronze fritté 30 microns nom. (ajouter «B» à la fin du code).
- Joint: NBR.
- Temperature de travail: de -30°C à +100°C.

**CARACTERÍSTICAS TÉCNICAS:**

- Cabeza y cuerpo: de plástico (poliamida 66) / cuerpo negro – cabeza roja.
- Filtro aire interno: esponja 40 micron nom. (sostituibile). Otras filtraciones bajo pedido.
- Para aplicaciones sujetas a fuertes rociadas de aceite, se sugiere el uso de filtro de aire 30 micras nom. de bronzo sinterizado (añadir "B" al final del código).
- Junta: NBR.
- Temperatura de trabajo: de -30°C a +100°C.

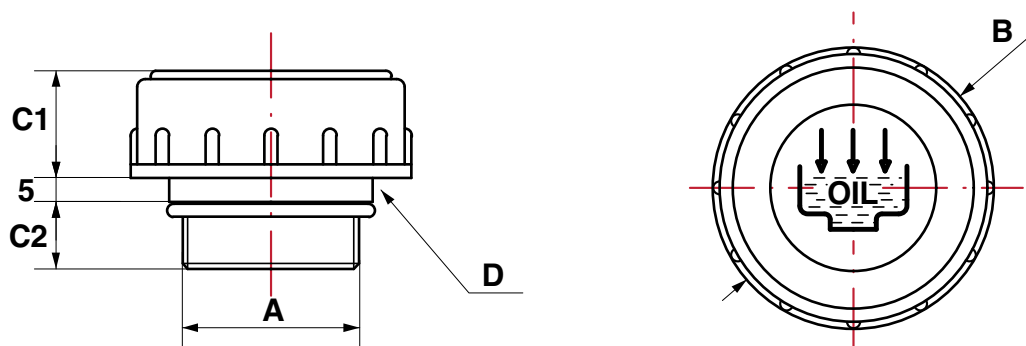

**TAPPO AVVITABILE IN PLASTICA - PLASTIC SCREWING CAP**

Mod.*	FILTRO ARIA - AIR FILTER		DIMENSIONI mm - DIMENSIONS mm				
	Micron nom.	Portata aria m³/h Air Flow m³/h	A	B	C1	C2	D
<b>TPL.38</b>	40 (foam replac.)	12	3/8" bspp	36	17	11	23
<b>TPL.12</b>	40 (foam replac.)	13,8	1/2" bspp	41	18	12	28
<b>TPL.34</b>	40 (foam replac.)	21	3/4" bspp	47	17	12	33
<b>TPL.1</b>	40 (foam replac.)	24	1" bspp	52	20	12	38
<b>TPL.114</b>	40 (foam replac.)	36	1"1/4 bspp	63	23	13	49
<b>TPL.112</b>	40 (foam replac.)	36	1"1/2 bspp	63	23	13,5	55
<b>TPL.1615</b>	40 (foam replac.)	13,8	M 16x1,5	36	17	11	23
<b>TPL.1815</b>	40 (foam replac.)	13,8	M 18x1,5	41	17,5	12	28
<b>TPL.2015</b>	40 (foam replac.)	13,8	M 20x1,5	41	17,5	12	28
<b>TPL.2215</b>	40 (foam replac.)	13,8	M 22x1,5	41	17,5	12	28

\* Aggiungere "B" alla fine del codice per filtro aria in bronzo sinterizzato.

\* Add "B" to code's end for air filter in sintered bronze.

# SERIE FAS

## IT Filtri a secco aspirazione aria e sfiato serbatoi.

### CARATTERISTICHE TECNICHE:

- Coperchio filtro: acciaio verniciato nero.
- Supporto interno filtro: acciaio verniciato nero.
- Guarnizioni tenuta cartuccia: NBR.
- Viti chiusura e fascetta (tipo 2): in acciaio zincato.
- Cartuccia interna: Standard carta 5/7 micron nom. / "X" rete vellutata micron 40 micron nom. / "P" poliestere 20 micron nom. / "I" inox 60 micron nom. Altri elementi filtranti su richiesta.

## EN Suction dry air filters and tank breathers.

### TECHNICAL FEATURES:

- Filter cover: black painted steel.
- Inner filter structure: black painted steel.
- Sealing cartridge gaskets: NBR.
- Closing screws and clamp (type 2): galvanized steel.
- Inner air cartridge: standard paper 5/7 micron nom. / "X" velvet mesh 40 micron nom. / "P" polyester 20 micron nom. / "I" stainless steel 60 micron nom. Other filter element upon request.

## D Saugtrockenlüftfilter und TankbelüftungsfILTER.

### TECHNISCHE DATEN:

- Filterdeckel: schwarz lackiertem Stahl.
- Innenfilter Struktur: schwarz lackiertem Stahl.
- Abdichtung Patrone Dichtungen: NBR.
- Verschlusschrauben und Schelle (typ 2): verzinktem Stahl.
- Inneren Lüftfilterpatrone: standard Papier 5/7 Mikron nom. / "X" Samtigesnetz 40 micron nom. / "P" Polyester 20 Mikron nom. / "I" Edelstahlrahtgewebe 60 Mikron nom. weitere Materialien auf Anfrage Erhältlich.

## F Filtres aspiration à air sec et reniflards réservoir.

### CARACTERISTIQUES TECHNIQUES:

- Couvercle filtre: acier peint noir.
- Structure interne du filtre: acier peint noir.
- Joint d'étanchéité cartouche: NBR.
- Vis de fermeture et bride (type 2): acier galvanisé.
- Filtre air intérieur: Standard papier 5/7 micron nom. / „X“ toile volutée 40 micron nom. / „P“ polyester 20 Micron nom. / „I“ acier inox 60 Micron nom. Autres matériaux sur demande.

## ES Filtros aspiración aire a seco y venteo depósitos.

### CARACTERÍSTICAS TÉCNICAS:

- Cubierta filtro: acero pintado negro.
- Estructura filtro interno: acero pintado negro.
- Junta de estanqueidad elemento: NBR.
- Tornillos de cierre y abrazadera (tipo 2): acero galvanizado.
- Filtro interno: estándar papel 5/7 micron nom. / "X" malla de terciopel / "P" poliestere 20 micron nom. / "I" acero inox 60 micron nom. Otros materiales bajo pedido.

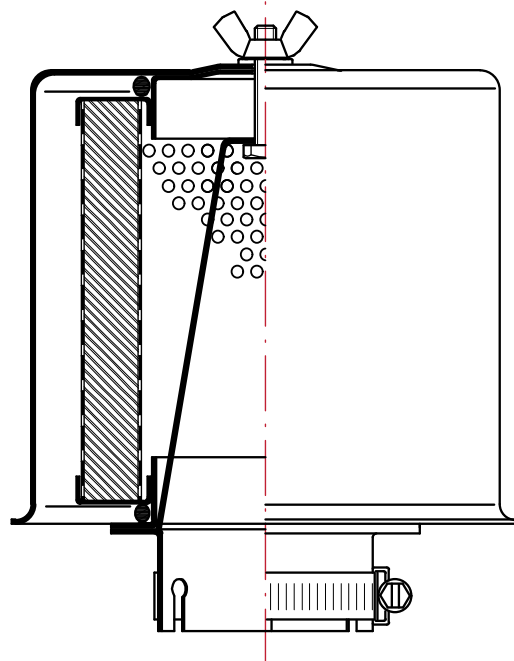

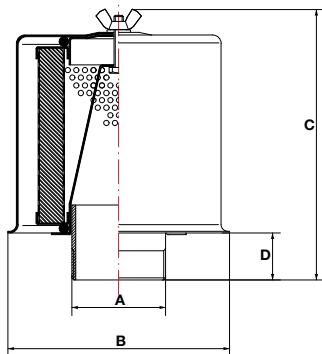

### TIPO 1/TYPER 1: ATTACCO FILETTATO - THREADED CONNECTION

Modello* con cartuccia in carta Model* with paper cartridge	Port.-Cap. m <sup>3</sup> /h**		Dimensioni - Dimensions mm				Cartuccia ricambio - Spare cartridge			
	Carta Paper	Rete vell. Vel. mesh	A	B	C	D	Carta Paper	Rete vellutata Velvet mesh	Poliestere Polyester	Inox Stainless Steel
FAS.04499	10	18	1/4" bspp	55	45	25	MF9.04701	AS2.03666	MF9.04701P	AS3.05370
FAS.04500	10	18	M 12X1.5	55	45	25	MF9.04701	AS2.03666	MF9.04701P	AS3.05370
FAS.04501	10	18	3/8" bspp	55	45	30	MF9.04701	AS2.03666	MF9.04701P	AS3.05370
FAS.04502	25	40	1/2" bspp	79	60	30	MF9.04702	AS2.03662	MF9.04702P	AS3.05371
FAS.04503	45	68	3/4" bspp	104	90	30	MF9.04703	AS2.03681	MF9.04703P	AS3.03644
FAS.04520	45	68	M 26X1.5	104	90	30	MF9.04703	AS2.03681	MF9.04703P	AS3.03644
FAS.04504	100	140	1" bspp	130	100	40	MF9.02658	AS2.03682	MF9.02658P	AS3.03645
FAS.04519	125	170	1"1/4 bspp	130	100	40	MF9.02658	AS2.03682	MF9.02658P	AS3.03645
FAS.04505	150	200	1"1/2 bspp	130	130	45	MF9.04705	AS2.03683	MF9.04705P	AS3.03712
FAS.04506	250	320	2" bspp	130	130	60	MF9.04705	AS2.03683	MF9.04705P	AS3.03712
FAS.04507	300	420	2" bspp	172	160	50	MF9.02657	AS2.03685	MF9.02657P	AS3.03689
FAS.04508	500	650	2"1/2 bspp	195	160	60	MF9.04706	AS2.03686	MF9.04706P	AS3.05372
FAS.04509	900	1.200	3" bspp	290	190	60	MF9.04707	AS2.03687	MF9.04707P	MF9.04707I
FAS.04510	1.800	2.300	4" bspp	336	240	60	MF9.04708	AS2.03688	MF9.04708P	AS3.05373

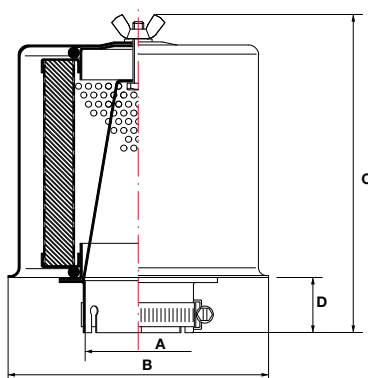

### TIPO 2/TYPER 2: ATTACCO A FASCETTA - CLAMP CONNECTION

Modello* con cartuccia in carta Model* with paper cartridge	Port.-Cap. m <sup>3</sup> /h**		Dimensioni - Dimensions mm				Cartuccia ricambio - Spare cartridge			
	Carta Paper	Rete vell. Vel. mesh	A	B	C	D	Carta Paper	Rete vellutata Velvet mesh	Poliestere Polyester	Inox Stainless Steel
FAS.04511	54	68	20	104	90	20	MF9.04703	AS2.03681	MF9.04703P	AS2.03644
FAS.04512	100	140	40	130	100	20	MF9.02658	AS2.03682	MF9.02658P	AS2.03645
FAS.04513	150	200	52	130	130	20	MF9.04705	AS2.03683	MF9.04705P	AS2.03712
FAS.04514	300	420	60	172	160	20	MF9.02657	AS2.03685	MF9.02657P	AS2.03689
FAS.04515	500	420	80	195	160	25	MF9.04706	AS2.03686	MF9.04706P	AS2.05372
FAS.04516	500	650	90	195	160	25	MF9.04706	AS2.03686	MF9.04706P	AS2.05372
FAS.04517	900	1200	100	290	190	25	MF9.04707	AS2.03687	MF9.04707P	MF9.04707I
FAS.04518	1800	2300	140	336	240	25	MF9.04708	AS2.03688	MF9.04708P	AS3.05373

\* CARTUCCIA RETE VELLUTATA: AGGIUNGERE "X" AL CODICE - CARTUCCIA POLIESTERE: AGGIUNGERE "P" AL CODICE - CARTUCCIA INOX: AGGIUNGERE "I" AL CODICE  
\* VELVET MESH CARTRIDGE: ADD "X" TO CODE'S END - POLYESTER CARTRIDGE: ADD "P" TO CODE'S END - ST. STEEL CARTRIDGE: ADD "I" TO CODE'S END

\*\* PORTATE RILEVATE CON 200 mm H<sub>2</sub>O DI PERDITA DI CARICO

\*\* CAPACITY MEASURED WITH 200 mm H<sub>2</sub>O PRESSURE LOSS

# SERIE PV

## IT Serbatoi e barilotti di compensazione

### CARATTERISTICHE TECNICHE:

- Materiale di costruzione: acciaio verniciato a polvere nero.
- Test controllo tenuta: 100% su tutta la produzione.
- Su richiesta si eseguono produzioni speciali su disegno e specifiche tecniche del cliente.

## EN Compensation tanks and barrels

### TECHNICAL FEATURES:

- Construction material: black dust painted steel.
- Leakage control test: 100% on all production.
- Special productions made by drawing or customer technical specifications are available upon request.

## D Ausgleichbehälter

### TECHNISCHE DATEN:

- Baumaterial: Schwarzerstaublackiertemstahl.
- Dichtheitsprüfung: 100% für alle Produktion.
- Sonderausführungen nach Zeichnung oder Kunden technische Spezifikationen sind auf Anfrage erhältlich.

## F Réservoirs et barillets de compensation

### CARACTERISTIQUES TECHNIQUES:

- Matériel de construction: acier verni a poudre noir.
- Test contrôle d'étanchéité: 100% sur toute la production.
- Productions spéciales faites par dessin ou spécifications techniques du client sont disponibles sur demande.

## ES Tanques y barrilejos de compensación

### CARACTERÍSTICAS TÉCNICAS:

- Material de construcción: acero embarnizado en polvo negro.
- Test de retención: 100% de la producción.
- Producciones especiales para diseño o especificaciones técnicas del cliente disponibles bajo pedido.

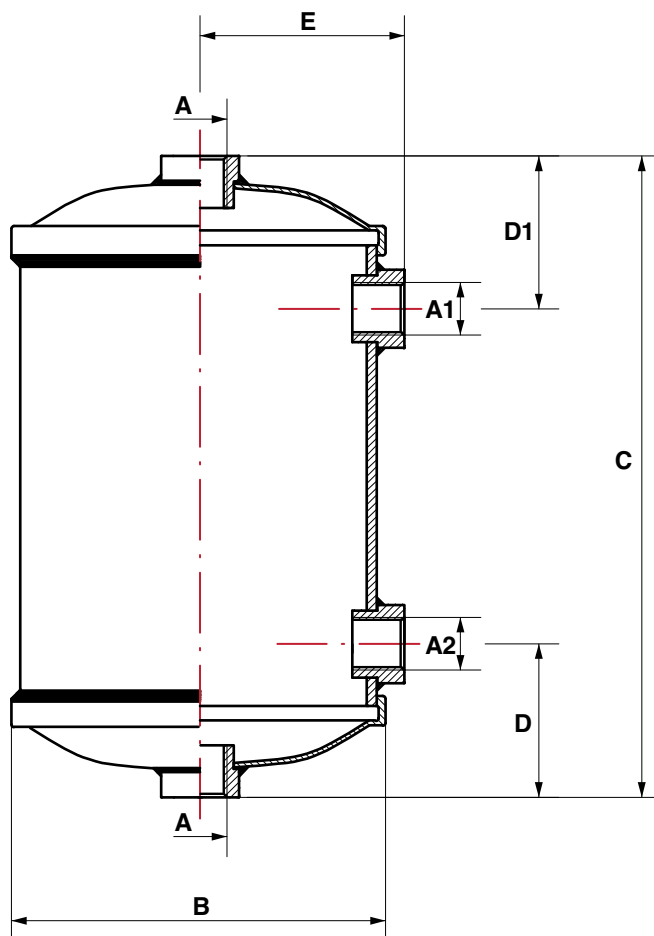

DIMENSIONI mm - DIMENSIONS mm

Mod.	A	A1	A2	B	C	D	D1	E	LITRI LITERS
PV9.05511	3/8" bspp	-	-	Ø 62	90	-	-	-	0,15
PV9.03894	3/8" bspp	1/4" bspp	-	Ø 79	118	-	40	48	0,3
PV9.03887	3/8" bspp	-	-	Ø 79	118	-	-	-	0,3
PV9.03888*	1/2" bspp	-	-	Ø 105	150	-	-	-	0,9
PV9.03885	3/8" bspp	3/8" bspp	3/8" bspp	Ø 105	206	53	53	60	1,2
PV9.01731	3/8" bspp	3/8" bspp	3/8" bspp	Ø 105	243	66	66	60	1,5
PV9.05509**	3/4" bspp	3/8" bspp	1"1/4 bspp	Ø 105	243	66	153	60	1,5
PV9.05569	3/8" bspp	3/8" bspp	3/8" bspp	Ø 105	380	55	55	60	2

\* Con staffa fissaggio  
with fixing bracket

\*\* Ghiere laterali non in asse  
Lateral ring nuts not on same axis





**F.B.N. srl**

Via Enzo Ferrari, 1/3/5 • 42017 NOVELLARA (RE) - ITALY

Tel. +39 0522 654437 • Fax +39 0522 662916

**[fbn@fbn.it](mailto:fbn@fbn.it) • [www.fbn.it](http://www.fbn.it)**